

Product:

EBM30N/TEG

Title:

Installation and User Guide



Document Number:

81773-4

Issue:

2

Date:

10/August/2021

Change History

ISSUE	DATE	NAME	SECTION	CHANGE
1	02/Aug/21	JS	All	Created from 80463-4
2	10/Aug/21	JS	1, 3.3.2 1.2 3.3.1, 3.3.2	Output name updated to "Bias Cancellation" to distinguish from Bias output Bias and Bias Cancellation description updated Pinout indication added to low voltage receptacles

Contents

1	Description	5
1.1	Rated Outputs.....	5
1.2	Bias Output and Bias Cancellation Supply	5
1.3	Block Diagram	6
1.4	Environmental Conditions.....	6
2	Safety	7
2.1	Meaning of Symbols	7
3	Installation of the HV Unit	8
3.1	Mechanical Installation	8
3.2	Electrical Installation	8
3.3	Connecting the Power Supply	8
3.3.1.	Input Power Connector - PL1	8
3.3.2.	Control Connectors – PL2 and PL3.....	9
3.3.3.	Input Power and Control Connectors Accessory Kit	10
3.3.4.	High Voltage Connector and Cables	10
3.3.5.	Scintillator Output and Cables	11
3.3.6.	PMT and Collector Outputs	11
4	Operation of the HV Unit.....	12
4.1	Control Signals	12
4.2	Monitor Signals	12
5	Protection	13
	Appendix 1 – EBM30N/TEG Outline Drawing	14
	Appendix 2 - HV Cable Assembly	15
	Appendix 3 – Scintillator Cable Assembly	16

EBM30N/TEG – Installation and User Guide	Document Number: 81773-4	Issue: 2
Spellman High Voltage Electronics Limited +44 (0)1798 877000 hvsales@spellmanhv.co.uk Broomers Park, Pulborough, W. Sussex, UK. RH20 2RY		

SAFETY

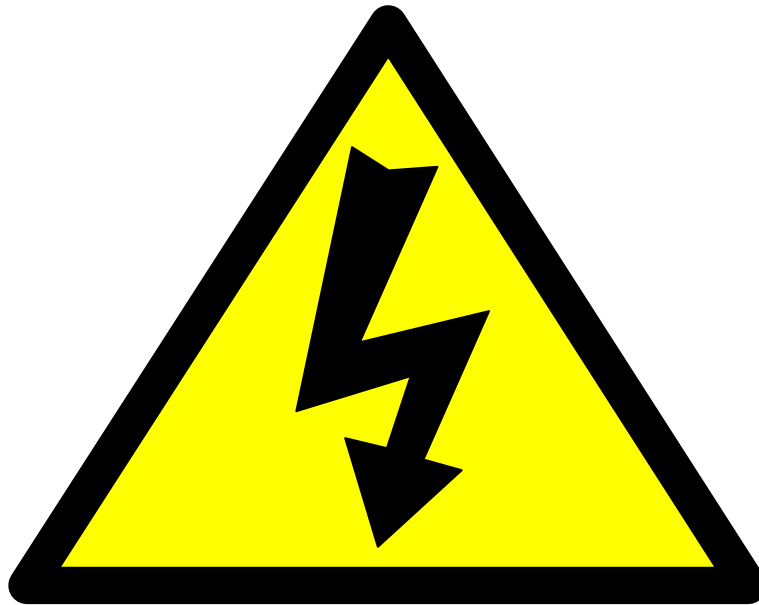

DANGER HIGH VOLTAGE RISK OF ELECTROCUTION

Observe extreme caution when working with this equipment

- High voltage power supplies must always be connected to protective earth
- Do not touch connections unless equipment is turned off and the capacitance of both the load and power supply are grounded
- Allow adequate time for discharge of internal capacitance of the power supply
- Do not ground yourself or work under wet or damp conditions

Servicing Safety

- Maintenance may require removing the Instrument cover with the power on
- Servicing should only be done by qualified personnel aware of the hazards
- Return to supplier for servicing

SÉCURITÉ

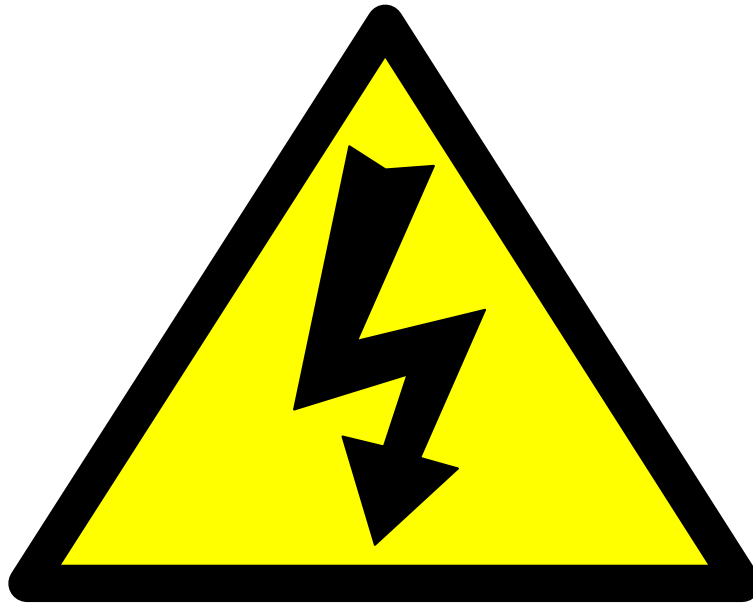

DANGER HAUTE TENSION RISQUE D'ÉLECTROCUTION

Observez une extrême prudence lorsque vous travaillez avec cet équipement

- Les alimentations haute tension doivent toujours être connectées au conducteur de protection.
- Ne pas toucher les connexions à moins que l'équipement soit éteint et que la capacité de la charge et de l'alimentation électrique ne soit mise à la terre.
- Prévoir un temps suffisant pour la décharge de la capacité interne de l'alimentation.
- Ne pas vous mettre à la terre ou travailler dans des conditions humides.

Sécurité d'entretien

- L'entretien ne doit être effectué que par un personnel qualifié et conscient des dangers.
- Il n'y a pas de pièce remplaçables par l'utilisateur dans l'unité, retourner au fournisseur pour l'entretien.

1 Description

The EBM30N/TEG consists of one chassis containing a complete high voltage power supply to power the main components within a Scanning Electron Microscope (SEM).

The chassis is approximately 105mm x 190mm x 250mm.

1.1 Rated Outputs

Output	Rating	Notes
Accelerator	-30kV, 170µA	Internal Supply. Voltages up to 32kV can be generated.
Bias Cancellation	3.5kV, 150µA	Internal Supply. Referenced to Accelerator output.
Bias	N/A	See section 1.2
Filament	15W max into 1Ω	Referenced to Accelerator output.
P.M.T.	1.3kV, 1mA	Referenced to ground.
Scintillator	11kV, 250 µA	Referenced to ground.
Collector	500V, 5mA	Referenced to ground.

The 'source' outputs (accelerator, bias and filament) are provided at a Claymount mini 75 receptacle.

The P.M.T. and Collector outputs are provided at BNC.HT connectors (Radiall R316 553)

The Scintillator output is provided at a bespoke 'poke-home' receptacle.

All control and monitoring is by analogue and TTL level signals.

1.2 Bias Output and Bias Cancellation Supply

The Bias Output is not controlled directly: it is referenced to the Accelerator Output and varies with the load current and the Bias Cancellation Supply as described below.

The negative Bias voltage is generated by the feedback resistor current and the load current flowing from the accelerator through a 20MΩ +/-5% resistor to the filament centre tap. See the block diagram in the next section. The maximum off-load Bias voltage is therefore dependent upon the accelerator voltage and the 500MΩ feedback resistor as shown in the block diagram.

Beam (emission) current conduction is achieved by cancelling this bias voltage with the positive polarity Bias Cancellation supply.

An Accelerator output of -30kV will generate a current of -60uA feedback into the 500M feedback resistor, which is equal to a voltage of -1200V generated across the 20MΩ resistor.

So, the Bias sits at -31200V which blocks the flow of electrons. The positive Bias Cancellation voltage reduces the negative Bias output allowing the emission current to flow.

EBM30N/TEG – Installation and User Guide	Document Number: 81773-4	Issue: 2
Spellman High Voltage Electronics Limited +44 (0)1798 877000 hvsales@spellmanhv.co.uk Broomers Park, Pulborough, W. Sussex, UK. RH20 2RY		

1.3 Block Diagram

A block diagram of the unit and its interconnection with the SEM is shown below.

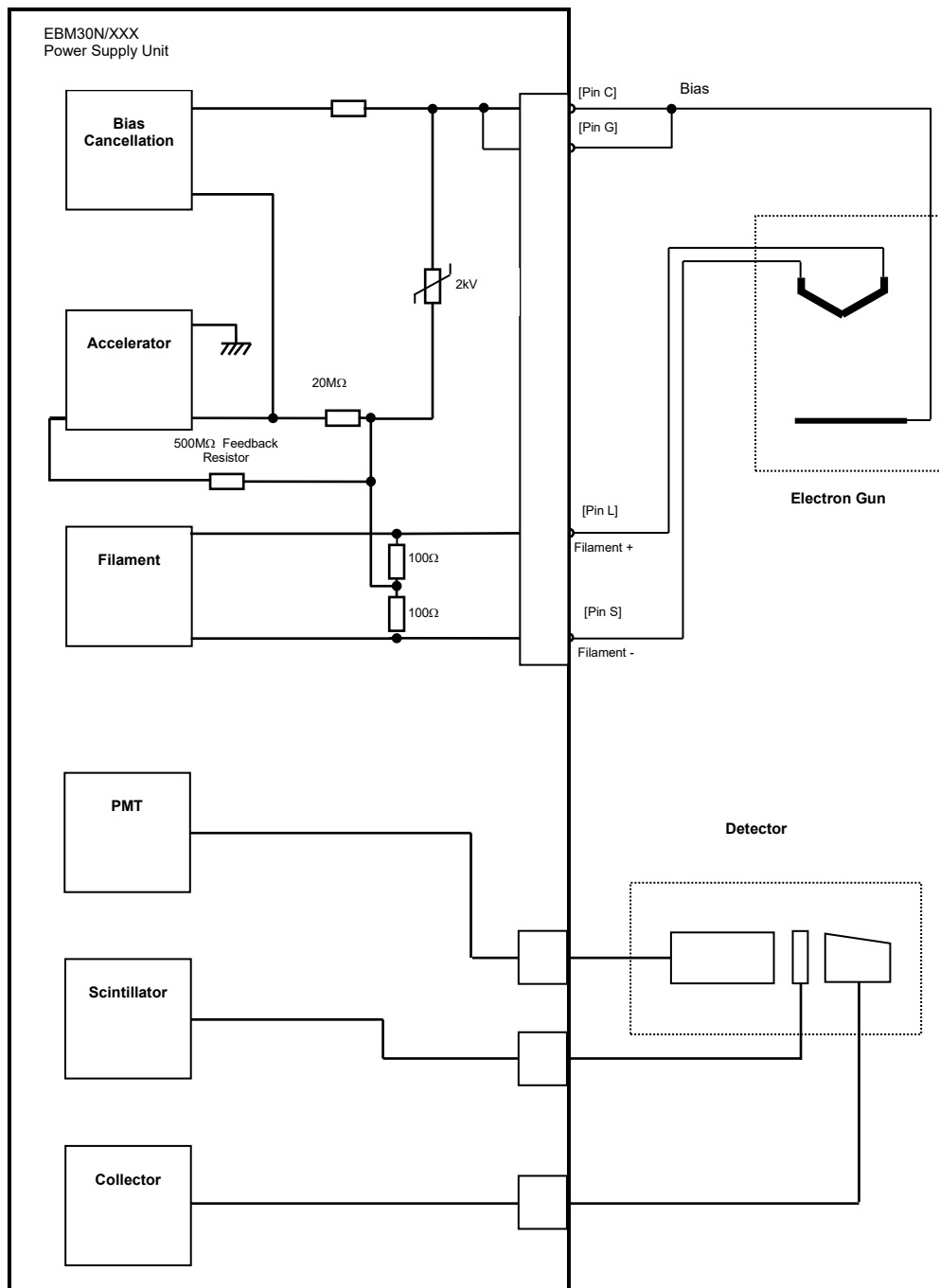

1.4 Environmental Conditions

Operating Temperature: 10°C to +45°C for normal operation, however the unit will operate from 0°C but with an extended warm up period.

Storage Temperature: -20°C to +75°C

Humidity: 0% to 85% RH (non-condensing)

EBM30N/TEG – Installation and User Guide	Document Number: 81773-4	Issue: 2
Spellman High Voltage Electronics Limited +44 (0)1798 877000 hvsales@spellmanhv.co.uk Broomers Park, Pulborough, W. Sussex, UK. RH20 2RY		

2 Safety

The conditions of this manual must be complied with to maintain safety. Operating the unit in a manner not specified in this manual may impair the protection against electric shock provided by the unit.

The unit is UL listed to UL61010-1 and CE marked to EN60101-1.

The following outputs are classed as hazardous, as defined by 61010-1:

- Accelerator
- Bias
- P.M.T
- Collector
- Scintillator

The unit is contained in an earthed case. The earth stud of the unit shall be properly bonded to the main protective earth termination in the end product.

The unit has been evaluated for use in a Pollution Degree 2, Installation Category II environment.

Consideration should be given to conducting the following tests with the unit installed in the end product:

- Dielectric Voltage Withstand Test, between live parts of the unit and the end product chassis.
- Permissible Limits Tests with the unit installed in the end product.
- Temperatures on power electronic components, transformer windings and accessible surfaces.





The unit must be terminated safely before operation. Hazardous voltages will be exposed if the connector is removed whilst the unit is enabled. The Earth stud of the unit is a protective earth and must be connected to the earth of the system.

The unit must be switched off for at least one minute before disconnecting any of the connectors or removing the access panel.

The unit is intended for use as a component and no surface of the unit should be accessible in the end product.

Note: Failure to comply with the above could compromise the safe operation of the unit and invalidate the warranty.

2.1 Meaning of Symbols

SYMBOL	MEANING
	Refer to manual before operating
	Caution, possibility of electric shock
	Protective conductor terminal (PE)
	Functional Earth

EBM30N/TEG – Installation and User Guide	Document Number: 81773-4	Issue: 2
Spellman High Voltage Electronics Limited +44 (0)1798 877000 hvsales@spellmanhv.co.uk Broomers Park, Pulborough, W. Sussex, UK. RH20 2RY		

3 Installation of the HV Unit

3.1 Mechanical Installation

The EBM30N/TEG unit must be fitted in the end product and secured in position with screws.

The unit should only be used in a Pollution Degree 2 Installation Category II environment.

The unit is intended for use as a component and no surface of the unit should be accessible in the end product.

The mechanical outline of the unit is shown in Appendix 1 – EBM30N/TEG Outline Drawing.

The EBM30N/TEG must be fitted in a unit and secured in position using the mounting brackets provided. A safety interlock should be used to prevent access to the unit when it is operating.

The unit should only be used in a Pollution Degree 2 Installation Category II environment.

Weight: 7.5 Kg

3.2 Electrical Installation

Input Rating: The EBM30N/TEG is designed for operation from a UL recognised, double insulated or SELV 24Vdc ($\pm 5\%$) supply, the maximum continuous current requirement is 2.5A.

3.3 Connecting the Power Supply

The input and output connectors are not intended for field connections and should only be connected to internal wiring in the end use equipment.

The unit is not supplied with cables for power and communications, for installation of the unit into a given system all cabling must be prepared to suit the respective interfaces.

A low voltage connectors accessory kit, HV Out and Scintillator mating cables are available for order, see following sections for details.

The power, control and HV connections to the unit are detailed in the following sections of this manual.

3.3.1. Input Power Connector - PL1

Manufacturer		JST		Model B 5PS-VH	
pin#	Signal	I/O	Description	Remarks	
1	+24V	I	DC24V Input	Pins connected internally	
2	+24V	I	DC24V Input		
3	0V	I	DC24V Common	Pins connected internally	
4	0V	I	DC24V Common		
5	FG	-	Case earth	Internally connected to 0V	

Receptacle pinout:

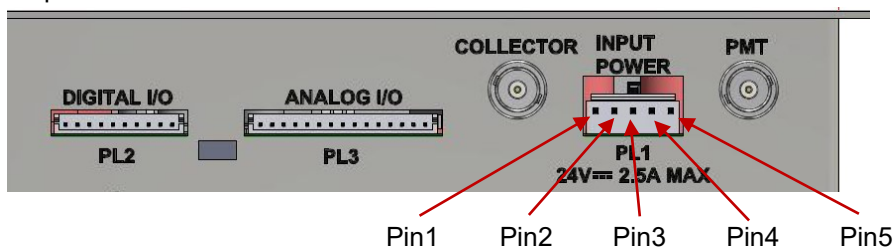

EBM30N/TEG – Installation and User Guide	Document Number: 81773-4	Issue: 2
Spellman High Voltage Electronics Limited +44 (0)1798 877000 hvsales@spellmanhv.co.uk Broomers Park, Pulborough, W. Sussex, UK. RH20 2RY		

3.3.2. Control Connectors – PL2 and PL3

Analog In/Out Connector PL3

Manufacturer JST Model S15B-EH				
pin#	Signal	I/O	Description	Remarks
1	Fil Prog(+)	I	0 to 4V = 0 to 4V Filament output	Differential-input
2	Fil Prog(-)	I		
3	Bias Cancel Prog(+)	I	0 to 3.5V = 0 to 3.5kV Bias Cancellation output	Differential-input
4	Bias Cancel Prog(-)	I		
5	Acc Prog(+)	I	0 to 6V = 0 to 30kV Accelerator output	Differential-input
6	Acc Prog(-)	I		
7	EMS	O	0 to 10V = 0 to 200uA Emission current. Limited to 12V maximum. ±3% or 0.1V, whichever is greater	
8	EMS 0V	O		
9	PMT Prog(+)	I	0 to 6.5V = 0 to 1300V P.M.T output	Differential-input
10	PMT Prog(-)	I		
11	Scintillator Prog (+)	I	0 to 5.5V = 0kV to 11kV Scintillator output	Differential-input
12	Scintillator Prog (-)	I		
13	Collector Prog	I	0 to 5V = 0 to 500V Collector output	Differential-input
14	Collector Prog 0V	I		
15	-	-	Not Used	

Digital In/Out Connector PL2

Manufacturer JST Model S10B-EH				
pin#	Signal	I/O	Description	Remarks
1	Remote on/off	I	Outputs 1,2 and 3 (Acc., Bias, Fil.) remote on/off	High = off
2	Remote 4 on/off	I	Output 4 remote on/off	High = off
3	Remote 5 on/off	I	Output 5 remote on/off	High = off
4	Remote 6 on/off	I	Output 6 remote on/off	High = off
5	Remote signal gnd	I	0V connection for remote controls	
6	Filament open cct	O	Open collector logic level LOW <0.5V at ≤1.6mA HIGH >2.5V at ≤-180uA	High = failed
7	Filament OC return	O		
8	-	-	Not Used	
9	-	-	Not Used	
10	-	-	Not Used	

Receptacles pinout:

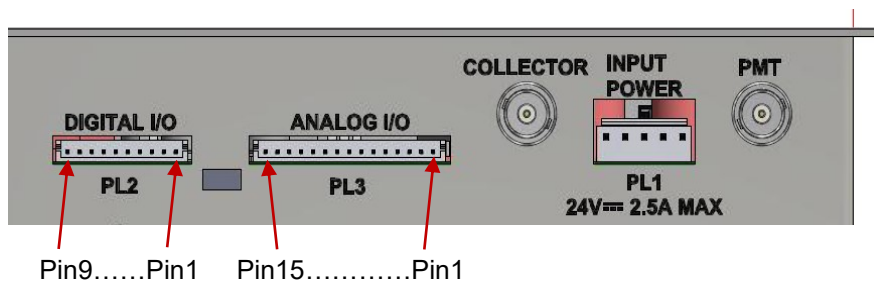

3.3.3. Input Power and Control Connectors Accessory Kit

An accessory kit is available to order free of charge which contains the mating housings and crimps for the low voltage connectors.

Low Voltage Mating Connectors Accessory Kit part number: 13802-27

3.3.4. High Voltage Connector and Cables

The unit uses a standard high voltage receptacle from Claymount: the CA11 (mini 75).

Claymount (www.claymount.com) can also provide mating cable assemblies terminated with mini75 high voltage plug.

Spellman can provide a cable assembly in different lengths, terminated one end in the mini 75 and the other end open.

Drawing is shown in Appendix 2 - HV Cable Assembly

Part numbers are:

HV Cable Assembly part number	Cable Length
HVC30/3SO/1317	2m
HVC30/3SO/1314	3m
HVC30/3SO/1315	5m

HV Cable Assembly Connector:

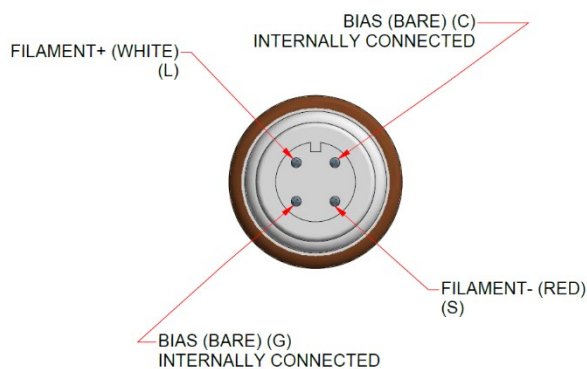

EBM30N/TEG – Installation and User Guide	Document Number: 81773-4	Issue: 2
Spellman High Voltage Electronics Limited +44 (0)1798 877000 hvsales@spellmanhv.co.uk Broomers Park, Pulborough, W. Sussex, UK. RH20 2RY		

3.3.5. Scintillator Output and Cables

This uses a bespoke 'Poke home' receptacle manufactured by Spellman HV with an 9mm ISO metric thread, 39mm deep. See drawing in Appendix 3 – Scintillator Cable Assembly.

Different lengths scintillator mating cables for the 'Poke home' receptacle are available to order.

Scintillator Cable Assembly part number	Cable Length
HVC11/1SO/1320	1m
HVC11/1SO/1316	2m

3.3.6. PMT and Collector Outputs

These outputs use an industry standard BNC.HT connector (i.e. Radiall R316 553)

EBM30N/TEG – Installation and User Guide	Document Number: 81773-4	Issue: 2
Spellman High Voltage Electronics Limited +44 (0)1798 877000 hvsales@spellmanhv.co.uk Broomers Park, Pulborough, W. Sussex, UK. RH20 2RY		

4 Operation of the HV Unit

4.1 Control Signals

The EBM30N/TEG unit is controlled by analogue and digital inputs using the two signal I/O connectors shown in Section 3.3.2

The following table details the action of each control signal.

Input Signal	Level (Vdc or TTL)	Control
Accelerator program voltage	0 to 6V	This corresponds to 0 to 30kV Accelerator output
Bias Cancellation program voltage	0 to 3.5V	This corresponds to 0 to 3.5kV Bias Cancellation output
Filament program current	0 to 4V	This corresponds to 0 to 4V Filament output
P.M.T program voltage	0 to 6.5V	This corresponds to 0 to 1300V P.M.T output
Scintillator program voltage	0 to 5.5V	This corresponds to 0kV to 11kV Scintillator output
Collector program voltage	0 to 5V	This corresponds to 0 to 500V Collector output
Accelerator, Bias and Filament remote on/off	TTL input	Accelerator, Bias and Filament all disabled if signal is High
P.M.T output remote on/off	TTL input	P.M.T output disabled if signal is High
Scintillator output remote on/off	TTL input	Scintillator output disabled if signal is High
Collector output remote on/off	TTL input	Collector output disabled if signal is High

Note that TTL logic controls use the following levels:

low <0.8V

high >2.4V

High = off

4.2 Monitor Signals

The EBM30N/TEG is monitored by analogue and digital outputs using the two signal I/O connectors detailed in Section 3.2

The following table details the purpose of each monitor signal.

Output Signal	Level (Vdc or Logic)	Control
Emission Current Monitor	0 to 10V $\pm 3\%$ or 0.1V, whichever is greater	This corresponds to 0 to 200uA Emission current. Limited to 12V maximum
Filament voltage > 6V i.e. open circuit	Open collector logic level LOW <0.5V at $\leq 1.6\text{mA}$ HIGH >2.5V at $\leq 180\text{uA}$	High means the filament has failed

EBM30N/TEG – Installation and User Guide	Document Number: 81773-4	Issue: 2
Spellman High Voltage Electronics Limited +44 (0)1798 877000 hvsales@spellmanhv.co.uk Broomers Park, Pulborough, W. Sussex, UK. RH20 2RY		

5 Protection

All outputs are protected from arcs in the load and continuous short circuit.

The unit will withstand maximum voltage arcs with an average repetition rate of up to 0.1Hz.

If the Accelerator has more than 8 arcs in a nominal 10 second period the unit will shut down. If there are less than 8 arcs the unit will continue to operate. Arc events less than 100ms from the previous event will be ignored.

A shutdown event maybe reset by toggling the 'Outputs 1, 2&3 remote on/off' level off and on again or toggling the input power off and on again.

All low voltage inputs are protected against over voltage (up to 30V) and negative input voltages (up to -30V).

The maximum output voltage, even under single fault conditions, is 40kV.

EBM30N/TEG – Installation and User Guide	Document Number: 81773-4	Issue: 2
Spellman High Voltage Electronics Limited +44 (0)1798 877000 hvsales@spellmanhv.co.uk Broomers Park, Pulborough, W. Sussex, UK. RH20 2RY		

Appendix 1 – EBM30N/TEG Outline Drawing

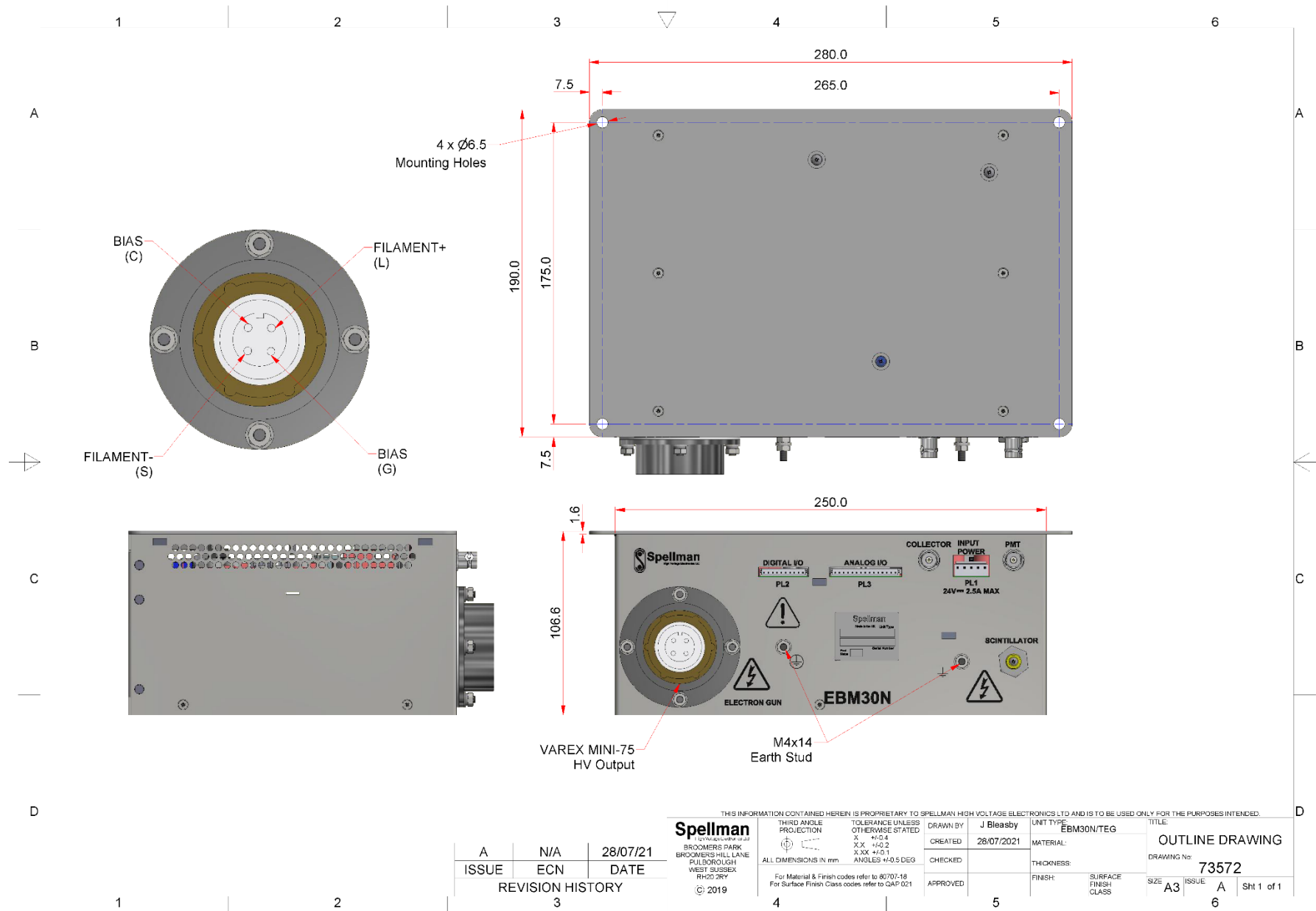

ISSUE	ECN	DATE
A	N/A	28/07/21
REVISION HISTORY		
		3

THIS INFORMATION CONTAINED HEREIN IS PROPRIETARY TO SPELLMAN HIGH VOLTAGE ELECTRONICS LTD AND IS TO BE USED ONLY FOR THE PURPOSES INTENDED.

Spellman <small>High Voltage Electronics Limited</small> BROOMERS PARK BROOMERS HILL LANE FULBOROUGH WEST SUSSEX RH20 2RY © 2019	THIRD ANGLE PROJECTION 	TOLERANCE UNLESS OTHERWISE STATED XX ±0.4 XX ±0.2 XX ±0.1 ALL DIMENSIONS IN mm ANGLES ±0.5 DEG	DRAWN BY: J Bleasby CREATED: 26/07/2021 CHECKED: APPROVED:	UNIT TYPE: EBM30N/TEG MATERIAL: THICKNESS: FINISH:	TITLE: OUTLINE DRAWING DRAWING No: 73572 SIZE: A3 ISSUE: A Sht 1 of 1
	<small>For Material & Finish codes refer to 80701-18 For Surface Finish Class codes refer to GAP-021</small>		FINISH:	SURFACE FINISH CLASS:	19001 Rev 2 (21-1-2017) V55X 1.0

Appendix 2 - HV Cable Assembly

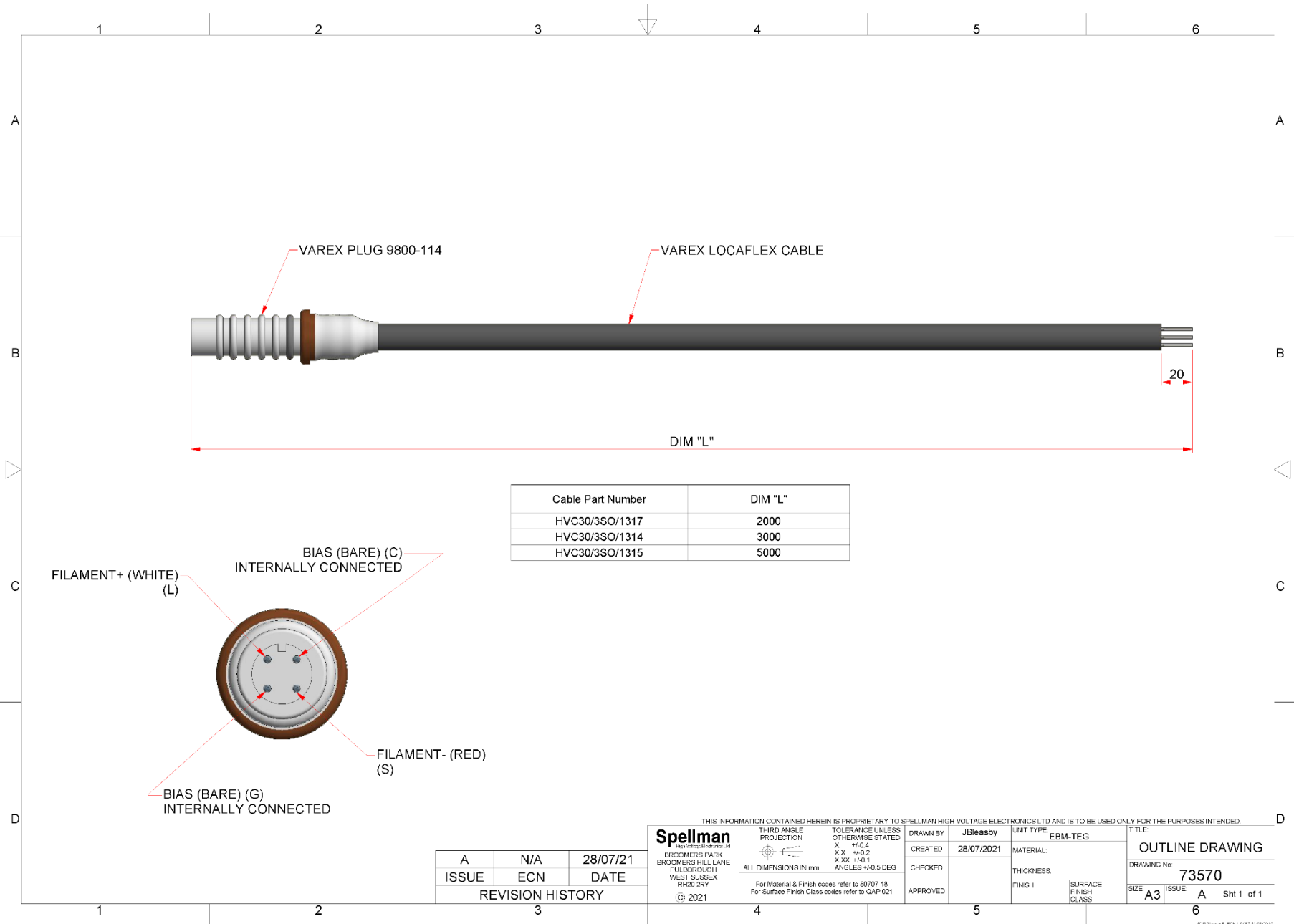

Appendix 3 – Scintillator Cable Assembly

