

Instruction Manual

EVA SERIES

High Voltage Power Supply

MODEL :
SERIAL# :
DATE :

**SPELLMAN
HIGH VOLTAGE ELECTRONICS
CORPORATION**

475 Wireless Blvd.
Hauppauge, New York, 11788

+1(631) 630-3000*FAX: +1(631) 435-1620*

E-mail: sales@spellmanhv.com

Website: www.spellmanhv.com

IMPORTANT SAFETY PRECAUTIONS

SAFETY

THIS POWER SUPPLY GENERATES VOLTAGES THAT ARE DANGEROUS AND MAY BE FATAL.
OBSERVE EXTREME CAUTION WHEN WORKING WITH THIS EQUIPMENT.

High voltage power supplies must always be grounded.

Do not touch connections unless the equipment is off and the Capacitance of both the load and power supply is discharged.

Allow five minutes for discharge of internal capacitance of the power supply.

Do not ground yourself or work under wet or damp conditions.

SERVICING SAFETY

Maintenance may require removing the instrument cover with the power on.

Servicing should be done by qualified personnel aware of the electrical hazards.

WARNING note in the text call attention to hazards in operation of these units that could lead to possible injury or death.

CAUTION notes in the text indicate procedures to be followed to avoid possible damage to equipment.

Copyright © 2000, Spellman High Voltage Electronics Corporation. All Rights Reserved.
This information contained in this publication is derived in part from proprietary and patent data. This information has been prepared for the express purpose of assisting operating and maintenance personnel in the efficient use of the model described herein, and publication of this information does not convey any right to reproduce it or to use it for any purpose other than in connection with installation, operation, and maintenance of the equipment described.

WICHTIGE SICHERHEITSHINWEISE

SICHERHEIT

DIESES HOCHSPANNUNGSNETZTEIL ERZEUGT LEBENSGEFÄHRLICHE HOCHSPANNUNG.
SEIN SIE SEHR VORSICHTIG BEI DER ARBEIT MIT DIESEM GERÄT.

Das Hochspannungsnetzteil muß immer geerdet sein.

Berühren Sie die Stecker des Netzteiles nur, wenn das Gerät ausgeschaltet ist und die elektrischen Kapazitäten des Netzteiles und der angeschlossenen Last entladen sind.

Die internen Kapazitäten des Hochspannungsnetzteiles benötigen ca. 5 Minuten, um sich zu entladen.

Erden Sie sich nicht, und arbeiten Sie nicht in feuchter oder nasser Umgebung.

SERVICESICHERHEIT

Notwendige Reparaturen können es erforderlich machen, den Gehäusedeckel während des Betriebes zu entfernen.

Reparaturen dürfen nur von qualifiziertem, eingewiesenem Personal ausgeführt werden.

“WARNING” im folgenden Text weist auf gefährliche Operationen hin, die zu Verletzungen oder zum Tod führen können.

“CAUTION” im folgenden Text weist auf Prozeduren hin, die genauestens befolgt werden müssen, um eventuelle Beschädigungen des Gerätes zu vermeiden.

PRECAUTIONS IMPORTANTES POUR VOTRE SECURITE

CONSIGNES DE SÉCURITÉ

CETTE ALIMENTATION GÉNÈRE DES TENSIONS QUI SONT DANGEUREUSES ET PEUVENT ÊTRE FATALES.
SOYEZ EXTRÊMEMENT VIGILANTS LORSQUE VOUS UTILISEZ CET ÉQUIPEMENT.

Les alimentations haute tension doivent toujours être mises à la masse.

Ne touchez pas les connectiques sans que l'équipement soit éteint et que la capacité à la fois de la charge et de l'alimentation soient déchargées.

Prévoyez 5 minutes pour la décharge de la capacité interne de l'alimentation.

Ne vous mettez pas à la masse, ou ne travaillez pas sous conditions mouillées ou humides.

CONSIGNES DE SÉCURITÉ EN CAS DE REPARATION

La maintenance peut nécessiter l'enlèvement du couvercle lorsque l'alimentation est encore allumée.

Les réparations doivent être effectuées par une personne qualifiée et connaissant les risques électriques.

Dans le manuel, les notes marquées « **WARNING** » attire l'attention sur les risques lors de la manipulation de ces équipements, qui peuvent entraîner de possibles blessures voire la mort.

Dans le manuel, les notes marquées « **CAUTION** » indiquent les procédures qui doivent être suivies afin d'éviter d'éventuels dommages sur l'équipement.

IMPORTANTI PRECAUZIONI DI SICUREZZA

SICUREZZA

QUESTO ALIMENTATORE GENERA TENSIONI CHE SONO PERICOLOSE E POTREBBERO ESSERE MORTALI.
PONI ESTREMA CAUTELA QUANDO OPERI CON QUESTO APPARECCHIO.

- Gli alimentatori ad alta tensione devono sempre essere collegati ad un impianto di terra.
- Non toccare le connessioni a meno che l'apparecchio sia stato spento e la capacità interna del carico e dell'alimentatore stesso siano scariche.
- Attendere cinque minuti per permettere la scarica della capacità interna dell'alimentatore ad alta tensione.
- Non mettere a terra il proprio corpo oppure operare in ambienti bagnati o saturi d'umidità.

SICUREZZA NELLA MANUTENZIONE.

- Manutenzione potrebbe essere richiesta, rimuovendo la copertura con apparecchio acceso.
- La manutenzione deve essere svolta da personale qualificato, coscio dei rischi elettrici.
- Attenzione alle **AVVERTENZE** contenute nel manuale, che richiamano all'attenzione ai rischi quando si opera con tali unità e che potrebbero causare possibili ferite o morte.
- Le note di **CAUTELA** contenute nel manuale, indicano le procedure da seguire per evitare possibili danni all'apparecchio.

Contents

EVA HIGH VOLTAGE POWER SUPPLY INTRODUCTION	1
1.1 DESCRIPTION OF THE EVA SERIES	1
1.2 STANDARD FEATURES	1
1.2.1 REMOTE OPERATING FEATURES	2
1.2.2 SYSTEM STATUS AND FAULT DIAGNOSTIC DISPLAY	2
1.3 INPUT VOLTAGE.....	3
1.4 OPTIONS.....	3
1.5 INTERPRETING THE MODEL NUMBER.....	4
EVA HIGH VOLTAGE POWER SUPPLY INSPECTION AND INSTALLATION	5
2.1 INITIAL INSPECTION	5
2.2 INPUT REQUIREMENTS.....	5
2.3 MECHANICAL INSTALLATION.....	5
2.4 AIRFLOW REQUIREMENTS	5
EVA HIGH VOLTAGE POWER SUPPLY OPERATING INSTRUCTIONS.....	7
3.1 OPERATION	7
3.2 STANDARD FEATURES	8
3.3 DIGITAL INTERFACE (RS-232/ETHERNET).....	10
EVA HIGH VOLTAGE POWER SUPPLY PRINCIPLES OF OPERATION	17
4.1 LINE RECTIFICATION AND FILTERING.....	17
4.2 INVERTER.....	18
4.3 HIGH VOLTAGE TRANSFORMER.....	18
4.4 HIGH VOLTAGE ASSEMBLY	18
4.5 SYSTEM CONTROL PWB	18
4.6 FRONT PANEL ASSEMBLY	18
EVA HIGH VOLTAGE POWER SUPPLY INPUT VOLTAGE & OPTIONS	19
5.1 180-264VAC, 3Ø INPUT - 3PH	19
5.2 180-264VAC, 1Ø INPUT - 1PH	19
5.3 360-528VAC INPUT - 400VAC.....	19
5.4 HIGH VOLTAGE CABLE LENGTH - LL(X)	19
5.5 TWO HIGH VOLTAGE CONNECTERS - HV2	19
5.6 THREE HIGH VOLTAGE CONNECTERS - HV3	19
5.7 FILAMENT GUN SUPPLY, 1 CHANNEL- FIL1.....	19
5.8 FILAMENT GUN SUPPLY, 2 CHANNEL- FIL2.....	19
5.9 FILAMENT GUN SUPPLY, 3 CHANNEL- FIL3.....	19
5.10 HIGH POWER FILAMENT - HPF	19
5.11 CUSTOM DESIGNED MODELS - X(#).....	19
EVA BEAM CONTROLLER INTRODUCTION	20
6.1 DESCRIPTION OF BEAM CONTROLLER (FILAMENT POWER SUPPLY)	20
6.2 STANDARD FEATURES	20
6.3 REMOTE OPERATING FEATURES	21
6.4 SYSTEM STATUS AND FAULT DIAGNOSTIC DISPLAY	21
6.5 OPTIONS.....	22
BEAM CONTROLLER INSPECTION, INSTALLATION AND CONFIGURATION	22
6.6 INITIAL INSPECTION	22
6.7 INPUT REQUIREMENTS.....	22
6.8 AIRFLOW REQUIREMENTS	22
6.9 CONFIGURATION	22
EVA BEAM CONTROLLER OPERATING INSTRUCTIONS	24

6.10	OPERATION	24
6.11	STANDARD FEATURES	26
MAINTENANCE		32
7.1	PERIODIC SERVICING	32
7.2	PERFORMANCE TEST	32
7.3	HIGH VOLTAGE DIVIDERS	32
REPLACEMENT PARTS		33
8.1	REPLACEMENT PARTS.....	33
8.2	CORRESPONDENCE AND ORDERING SPARE PARTS.....	33
FACTORY SERVICE		34
9.1	WARRANTY REPAIRS	34
9.2	FACTORY SERVICE PROCEDURES.....	34
9.3	ORDERING OPTIONS AND MODIFICATIONS	34
9.4	SHIPPING INSTRUCTIONS.....	34

Figures and Tables

FIGURE 2.1	EVA HIGH VOLTAGE POWER SUPPLY AIRFLOW	5
TABLE 2.1	INPUT VOLTAGE/CURRENT REQUIREMENTS	6
FIGURE 3.1	TYPICAL EVA OPERATING SETUP.....	10
FIGURE 3.2A	WIRING DIAGRAM FOR REMOTE PROGRAMMING VIA VOLTAGE SOURCE.....	11
FIGURE 3.2B	WIRING DIAGRAM FOR REMOTE PROGRAMMING VIA EXTERNAL RESISTANCE	11
FIGURE 3.3	REMOTE MONITOR TEST POINT DESIGNATIONS	12
FIGURE 3.4	REMOTE CONTROL OF POWER ON, HIGH VOLTAGE ON AND HIGH VOLTAGE OFF	ERROR! BOOKMARK NOT DEFINED.
FIGURE 3.5	EXTERNAL INHIBIT INTERFACE CIRCUIT.....	13
FIGURE 3.6	EXTERNAL INTERLOCK INTERFACE CIRCUIT	13
FIGURE 3.7	REMOTE HIGH VOLTAGE ON AND REMOTE HIGH VOLTAGE OFF INDICATOR.....	14
FIGURE 3.8	REMOTE OVERVOLTAGE ADJUST INTERFACE	14
FIGURE 3.9	REMOTE STATUS AND FAULT INDICATOR INTERFACE.....	15
FIGURE 3.10	JB1 REAR PANEL INTERFACE CONNECTER.....	16
FIGURE 6.1	EVA SYSTEM BLOCK DIAGRAM	20
TABLE 6.1	REAR PANEL DIP SWITCH CONFIGURATION.....	23
FIGURE 6.2	TYPICAL OPERATING SETUP	26
FIGURE 6.3	REMOTE PROGRAMMING VIA VOLTAGE SOURCES.....	27
FIGURE 6.4	REMOTE PROGRAMMING VIA RESISTANCE	28
FIGURE 6.5	REMOTE MONITOR DESIGNATIONS	28
FIGURE 6.6	REMOTE BEAM ON / BEAM OFF	29
FIGURE 6.7	EXTERNAL INTERLOCK INTERFACE CIRCUIT	29
FIGURE 6.8	REMOTE BEAM ON /BEAM OFF INDICATOR.....	30
TABLE 6.2	BEAM CONTROLLER 25 PIN D REMOTE INTERFACE CONNECTOR.....	31

Chapter 1

EVA HIGH VOLTAGE POWER SUPPLY INTRODUCTION

1.1 Description of the EVA Series



The EVA Series of high voltage power supplies provides very well regulated, low ripple high voltage in a highly efficient, compact design, specifically for electron beam coating applications. Extremely stable output voltage and digitally configurable arc intervention circuitry result in significant performance improvements over previously available technology.

All of these advancements are possible only by Spellman's long history in high voltage power conversion technology. This series of power supplies utilizes extremely advanced quasi-resonant PWM conversion techniques, along with sophisticated digital technology. Custom units to meet special requirements and specific applications can also be provided.

1.2 Standard Features

The EVA Series incorporates several standard features and software configurable items designed to optimize user utility, satisfaction and safety.

FRONT PANEL CONTROL POWER/HIGH VOLTAGE ON/HIGH VOLTAGE OFF SWITCHES: These intuitive front panel controls allow the user to easily turn the unit on and enable/disable the generation of high voltage.

FRONT PANEL INDICATOR LAMPS: CONTROL POWER ON, HIGH VOLTAGE OFF and HIGH VOLTAGE ON indicators are integral with the control switches and equipped with dual lamps for redundancy and safety.

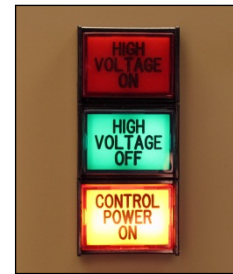

FRONT PANEL POTENTIOMETER: A ten turn potentiometer is provided for easy programming of the desired voltage regulation value.

FRONT PANEL DIGITAL METERS: 3.5 digit meters are provided to view the output voltage and current. A convenient Preset View Feature is provided: If the HIGH VOLTAGE OFF button is depressed and held in, the present voltage and current programming values will be displayed in actual kV and mA on the front panel meters.

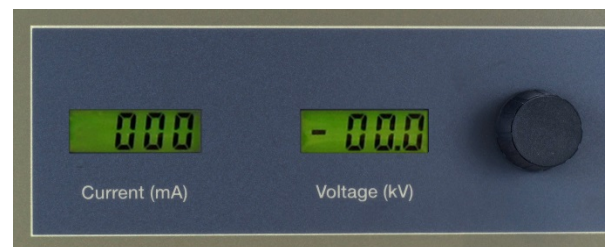

ETHERNET AND RS-232 INTERFACE: DSP based SMT circuitry provides both Ethernet and RS-232 digital interfacing capability simplifying the integration of the EVA into your system design. A VB GUI is provided for the RS-232 and Ethernet.

SLOW START RAMP TIME: This feature provides a gradual increase of high voltage until the preset operating point is reached. The slow start time is factory set for six seconds. Other slow start times can be software configured using the digital interface.

ARC QUENCH/ARC RERAMP/ARC TRIP: These features allow the user to tailor the power supply to meet specific needs in dynamic load applications. The standard configuration is if an arc occurs, the output is inhibited for approximately one millisecond (Arc Quench), and then the output is ramped up to the preset level in two milliseconds via the Arc ReRamp time period. If 25 arcs occur in a five second time period the unit will shut down displaying an "ARC" Fault (Arc Trip). Short term arcing = 5 arcs/second. A real time Arc Rate Limiter calculates the average arcing rate, if 50 arcs occur in a 30 second average time period the unit will shut down displaying an ARC fault. Long term arcing = 1.67 arcs/second. See Chapter 3 for operating details and information for user customization for these parameters via the software and the digital interface.

INTERNAL FAULT PROTECTION: The EVA series continually monitors internal circuits critical to the proper operation of the power supply. In the event that one of these circuits malfunctions, the fault detection circuit turns off the high voltage and reverts the unit to the POWER DOWN mode with the CONTROL POWER ON indicator lamp flashing slowly. The applicable fault indicator will be illuminated on the front panel diagnostic display requiring the user to clear (cycle the CONTROL POWER ON switch, cycle the AC line power or toggle the Reset/External Inhibit signal line) before high voltage can be re-enabled.

OUTPUT CABLE: All standard models are provided with a ten foot shielded high voltage output cable. The cable is designed so that it can be easily removed from the mating receptacle located on the rear of the chassis.

1.2.1 Remote Operating Features

REMOTE PROGRAMMING: Allows remote adjustment of the output voltage, current, power and overvoltage regulation parameters via the use of external 0-10Vdc = 0-100% rated output voltage sources.

REMOTE MONITORS: Allows remote monitoring of the output voltage, current and power test points where 0-10Vdc = 0-100% rated output.

REMOTE HIGH VOLTAGE CONTROL: Allows remote control of the HIGH VOLTAGE ON and HIGH VOLTAGE OFF functions. Signals are also provided for remote indication of HIGH VOLTAGE ON and HIGH VOLTAGE OFF status.

REMOTE POWER ON: Allows remote control of CONTROL POWER ON/OFF function. This feature also allows remote reset of the power supply when a SYSTEM FAULT shutdown occurs.

RESET/EXTERNAL INHIBIT: This circuit will reset any latched power supply faults and inhibit the high voltage output. A logic low/ground, will reset any fault(s) while inhibiting the high voltage output. A logic high/open will allow the high voltage to be enabled assuming the HIGH VOLTAGE ON switch (local or remote) cycled. NOTE: The External Inhibit circuit should NOT be used for protection against injury or for safety interlocking. See External Interlock for this type of safety control.

EXTERNAL INTERLOCK: Interlock connections are provided on the rear panel interface connector for connection to a customer implemented safety switch. The unit will not high voltage enable unless the interlock circuit is closed. During high voltage operation, opening the interlock circuit will cause the high voltage to shut off. This circuit should be used for safety interlock circuits. Spellman strongly recommends the use of External Interlocking for safety purposes.

1.2.2 System Status and Fault Diagnostic Display

"Dead Front" backlight type indicators provide system operation and fault condition information. If a fault occurs the power supply will revert to the POWER DOWN mode. This is indicated by the flashing of the CONTROL POWER ON indicator. To reset the latched fault: cycle the CONTROL POWER ON switch, cycle the AC line power or toggle the Reset/External Inhibit signal line.

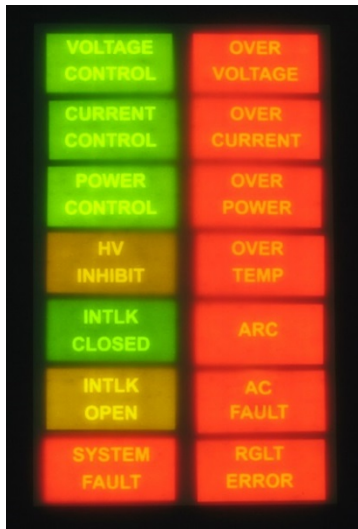

VOLTAGE CONTROL: Indicates the output voltage regulator circuit is maintaining voltage regulation.

CURRENT CONTROL: Indicates the output current regulator circuit is maintaining current regulation.

HV INHIBIT: Indicates the high voltage supply is being inhibited by either the EXTERNAL INHIBIT signal line or by internal protection circuitry.

INTLK CLOSED: Indicates the EXTERNAL INTERLOCK connections are in the closed position.

INTLK OPEN: Indicates the EXTERNAL INTERLOCK connections are in the open position. This also indicates opening of internal power supply interlocks. It is not possible to enable high voltage with an open EXTERNAL INTERLOCK.

SYSTEM FAULT: Indicates an internal fault has occurred.

OVER VOLTAGE: Indicates the overvoltage protection circuitry has caused the power supply to turn off. The default setting for the overvoltage protection circuitry is internally set to 105% of rated output voltage. This level can be set to anywhere from 0- 105% of rated output voltage by the user via the remote overvoltage programming capability, see Chapter 3 for more details.

OVER CURRENT: Indicates the output current has exceeded the programmed current trip level when the AOL (Adjustable Overload Trip) feature has been software configured using the digital interface.

OVER TEMP: Indicates that excessive temperature has been sensed within the chassis and internal protection circuitry has shut down the power supply.

ARC: Indicates that an arc has occurred (one second flash) or that the ARC Intervention Circuitry has shut down the power supply due to excessive arcing (latched “ARC” fault).

AC FAULT: Indicates a problem with the front end AC input circuitry and the corresponding generated inverter power buss voltages.

RGLT ERR: Indicates a failure in the voltage or current regulation circuitry. This fault usually occurs when there is a lack of output power to maintain proper regulation. Possible causes could be due to low AC input voltage (below low line parameters, or a missing phase) or a malfunction of the power supply preventing it from generating the voltage/current being requested.

1.3 Input Voltage

3PH Three Phase Input

180-264Vac, 50/60Hz three phase input voltage, available on 3kW, 6kW and 12kW units.

1PH Single Phase Input

180-264Vac, 50/60Hz single phase input voltage (3kW and 6kW units only).

400VAC 400 Volt Input

360-528Vac, 50/60Hz three phase input voltage (12kW units only).

1.4 Options

LL(X) High Voltage Cable Length

Custom length high voltage output cables, indicated in foot measurement units. Various predetermined lengths are available along with entirely custom lengths; contact Spellman Sales Department for details.

HV2 Two High Voltage Connectors

Optional two (2) high voltage output connectors that are connected in parallel for powering two beam channels with a single high voltage power supply.

HV3 Three High Voltage Connectors

Optional three (3) high voltage output connectors that are connected in parallel for powering three beam channels with a single high voltage power supply.

FIL1 Filament Gun Supply-One Channel

Optional beam controller (filament supply) and gun output box for single channel applications.

FIL2 Filament Gun Supply-Two Channels

Two optional beam controllers (filament supplies) and two gun output boxes for two channel applications.

FIL3 Filament Gun Supply-Three Channels

Three optional beam controllers (filament supplies) and three gun output boxes for three channel applications.

HPF High Powered Filament

50 amp filament power supply.

See Section 5 for more information on these options. With few exceptions, these options can be retrofitted to your power supply at the factory in a short time. For price and retrofit arrangements, contact Spellman's Sales Department at:

sales@spellmanhv.com

1.5 Interpreting the Model Number

The model number of the power supply describes its capabilities. After the series name "EVA" is:

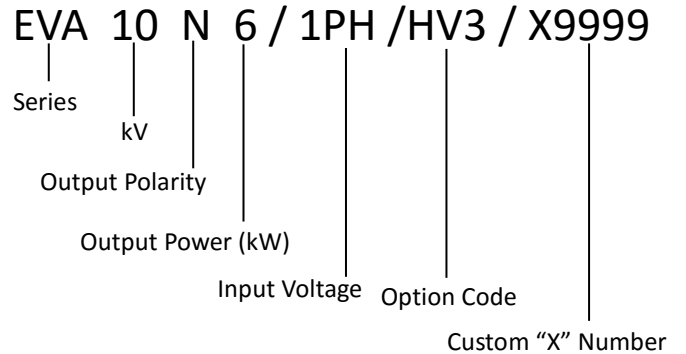

- The maximum voltage in kV (5, 10)
- The polarity of the unit: Negative (N)
- The maximum output power in kilowatts (3, 6, 12)
- The selected input voltage (3PH, 1PH, 400VAC)
- The option codes for all options that are included.
- Custom units have a unique 4 digit X number after the option code(s). This X number references a unique specification control drawing that takes precedent over the standard EVA data sheet specifications.

Chapter 2

EVA HIGH VOLTAGE POWER SUPPLY INSPECTION AND INSTALLATION

Initial inspection and preliminary checkout procedures are recommended. For safe operation, please follow the step-by-step procedures described in Chapter 3, Operating Instructions.

2.1 Initial Inspection

Inspect the package exterior for evidence of damage due to handling in transit. Notify the carrier and Spellman immediately if damage is evident. Do not destroy or discard any of the packing material used in a damaged shipment.

After unpacking, inspect the panel and chassis for visible damage.

Standard Spellman EVA high voltage power supplies are covered by a warranty. Custom and special order models (with an X suffix in the model number) are also covered by a warranty. Check the specific warranty terms by referring to the Warranty document contained in this operator's manual.

2.2 Input Requirements

For proper protection of the EVA power supply a circuit breaker protected, dedicated electrical service must be provided for each EVA chassis. EVA units are not phase dependent; the three AC input phase connections can be orientated in any manner with no adverse effect on power supply performance. See Table 2.1

2.3 Mechanical Installation

Units in the EVA series have front panel holes for standard EIA rack mounting. The rack must allow rear access for cable connections. Units are fully enclosed and are suitable for bench or tabletop operation. It is strongly recommended to support the chassis by guides or shelves.

2.4 Airflow Requirements

EVA units (3/6/12kW) are forced air cooled, air enters the chassis via openings on the right and left side panels and air is forcibly exhausted out the rear panel via a single fan. Whatever mechanical installation is implemented airflow into and out of the unit must not be compromised. Additionally it is the responsibility of the user to assure that air entering the unit is not above the maximum ambient temperature of 40°C. Airflow volume is 100cfm for 3/6kW units and 300cfm for 12kW units.



Figure 2.1 EVA High Voltage Power Supply Airflow

UNIT/INPUT VOLTAGE	FACTORY CONFIGURATION	MAXIMUM INPUT CURRENT PER PHASE
180-264Vac, 3 phase, 50/60Hz	3PH (3kW, 6kW & 12kW)	13 amps @ 3kW, 25 amps @ 6kW, 50 amps @ 12kW
180-264Vac, 1 phase, 50/60Hz	1PH (3kW & 6kW only)	29 amps @ 3kW, 57 amps @ 6kW
360-528Vac, 3 phase, 50/60Hz	400VAC (12kW only)	25 amps

Input Voltage Must Be Selected At Time of Order

Note: 400VAC Option (360-528Vac) units do **NOT** have a rear panel circuit breaker. For proper protection a circuit breaker/fuse protected dedicated 30 amp, three phase electrical service must be provided for each EVA chassis.

Table 2.1 Input Voltage/Current Requirements

The above maximum input current values assume a unit running at maximum power, operating at low line and taking power supply efficiency and power factor into account.

Chapter 3

EVA HIGH VOLTAGE POWER SUPPLY OPERATING INSTRUCTIONS

3.1 Operation

WARNING

THIS EQUIPMENT GENERATES DANGEROUS VOLTAGES THAT MAY BE FATAL. PROPER GROUNDING OF ALL HIGH VOLTAGE EQUIPMENT IS ESSENTIAL.

WARNING

BEFORE CONNECTING THE POWER SUPPLY TO THE AC LINE, FOLLOW THIS STEP-BY-STEP PROCEDURE.

DO NOT CONNECT THE POWER SUPPLY TO THE AC LINE UNTIL STEP 'G' IS REACHED. FAILURE TO FOLLOW THESE PROCEDURES MAY VOID THE WARRANTY.

- A) Insure that the front panel CONTROL POWER ON switch is in the OFF position (switch bezel out).
- B) Check the input voltage rating on the rear panel identification tag of the supply and make certain that this is the rating of the available power source.
- C) **PROPER GROUNDING TECHNIQUE:** The chassis of the high voltage power supply must be adequately grounded, preferably to the local "system ground" (cold water pipe ground, electrical conduit ground, copper ground rod, etc.) using a heavy gauge copper wire securely connecting to the ¼-20 ground stud on the rear panel of the unit. See Figure 3.1 for a typical operating setup.
- A heavy gauge user provided "load return" wire must be connected from the low end of the load back to the ¼-20 ground stud on the rear panel of the power supply. Using a separate external ground at the load is not recommended.

A six foot long, captive, three or four wire, unterminated line cord is provided for connecting to the AC supply.

For three phase input: BROWN, BLACK and BLUE wires are the three phase inputs, they are not phase dependent and can be connected in any manner. For single phase input: BROWN is line and BLUE is neutral. The GREEN/YELLOW or GREEN wire is for chassis safety ground connection. This is a safety ground connection and is NOT adequate for system grounding purposes.

Attach the high voltage output cable to the load.

- D) Plug the high voltage output cable provided with the unit into the rear of the supply and secure appropriately.
- E) **Options Note:** See section 5 for hook up and operating instructions for the options on your unit. Custom models may also require set up changes.
- F) For initial turn-on, rotate the front panel KILOVOLT control potentiometer fully counter-clockwise to the zero voltage position.
- G) The input power cable may now be connected to the AC power line.
- H) Depress the CONTROL POWER ON switch. The amber light inside the switch should light up. The unit is now in the HIGH VOLTAGE OFF mode. The HIGH VOLTAGE OFF light should be lit.
- I) Depress and hold the green HIGH VOLTAGE OFF switch. The front panel meters will now read the preset value of the KILOVOLT control dial and the MILLAMPERES internal preset value (100% rated current). To preset the desired level of the current and voltage during operation, depress and hold the green HIGH VOLTAGE OFF switch and rotate the control dial while noting its corresponding meter reading. Release the HIGH VOLTAGE OFF switch.

NOTE: No actual high voltage is being produced at this time.

- J) Depress the red HIGH VOLTAGE ON switch. The lamps inside the switch should illuminate and the output will slow start up to the preset level output voltage and/or output current.

NOTE: The EVA series is equipped with a slow start circuit that ramps the output up to its maximum setting

in approximately 6 seconds after the HIGH VOLTAGE ON switch is depressed.

K) To terminate the generation of output power, depress the HIGH VOLTAGE OFF switch. In the HIGH VOLTAGE OFF mode the power supply's fault and interface circuits are still active.

L) To turn off the power supply, depress the amber CONTROL POWER ON switch to release the switch bezel to the out position. All front panel lights should extinguish.

NOTE: If a power supply fault, or system monitoring fault occurs, the power supply will revert to the POWER DOWN mode. In this mode the output power will be turned off. The CONTROL POWER ON lamp will flash indicating a SYSTEM FAULT. To reset the SYSTEM FAULT cycle the CONTROL POWER ON switch, cycle the AC line power or toggle the RESET/EXTERNAL INHIBIT signal line.

WARNING

AFTER TURNOFF, DO NOT HANDLE THE LOAD UNTIL THE CAPACITANCE HAS BEEN DISCHARGED! LOAD CAPACITANCE MAY BE DISCHARGED BY SHORTING TO GROUND.

WARNING

THE VOLTMETER ON THE POWER SUPPLY FRONT PANEL DOES NOT READ THE OUTPUT VOLTAGE WHEN THE POWER IS TURNED OFF, EVEN IF A CHARGE STILL EXISTS ON THE LOAD.

CAUTION

TO ASSURE SAFETY AND PROPER COOLING ALWAYS OPERATE THE UNIT WITH THE COVER PANELS INSTALLED.

Internal fans maintain safe operating temperatures in the power supply by drawing air over the circuit components. The covers must be on in order to direct the air flow over the areas that need cooling. In operation, the units air intake and fan exhaust paths must be clear of any obstructions that might impede the flow of air.

3.2 Standard Features

A general note on remote interface circuitry and remote signal grounding:

When usage applications dictate, electrical isolation may be required when interfacing with the high voltage power supply in question. For power control signals such as CONTROL POWER, EXTERNAL INTERLOCK, HIGH VOLTAGE OFF and HIGH VOLTAGE ON isolated relay contacts should be used. For status signals and control signals such as HIGH VOLTAGE ON status, HIGH VOLTAGE OFF status, EXTERNAL INHIBIT, etc. opto-isolation should be used. When usage applications dictate, analog programming and monitoring signals may require isolation via analog isolation amplifiers. All interface cables should be properly shielded. All power supply signals should be referenced to the power supplies signal ground on the rear panel interface connector.

LOCAL/REMOTE PROGRAMMING: Allows adjustment of the output voltage and current via the front panel/internal controls (local) or external voltage sources (remote).

LOCAL CONTROL - In local control (front panel control), jumpers are installed on rear panel interface connector between pin 8 and pin 9 for current control and between pin 10 and pin 11 for voltage control. This will enable the front panel potentiometer for voltage control and an internal pull up for current control.

REMOTE CONTROL - For remote programming, the above mentioned jumpers are removed and a positive polarity, ground referenced voltage source is applied to the pin 8 for current and pin 10 for voltage. Programming signals should be referenced to pin 1, signal ground. Scaling is such that 0-10Vdc corresponds to 0-100% rated output respectively. See Figure 3.2A for wiring diagram.

An alternate method of controlling the output remotely is by using external resistance such as a potentiometer or a resistor network. For remote control the jumpers are removed and the desired resistor configuration is installed. See Figure 3.2B for wiring diagram.

REMOTE MONITORS: Test points are made available on the rear panel interface connector for monitoring the current and voltage; pin 5 and pin 6 respectively. The test points are always positive, scaling is such that 0-10Vdc corresponds to 0-100% rated output. Test points have an output impedance of 1k ohms, $\pm 1\%$. See Figure 3.3 for test point designation.

LOCAL/REMOTE CONTROL POWER/HV ON/HV OFF: Allows for command of CONTROL POWER, HIGH VOLTAGE ON and HIGH VOLTAGE OFF by either the front panel controls or external signals via the rear panel external interface connector.

LOCAL CONTROL - For local front panel switch command of the Control Power functionality a maintained connection between pin 12 and pin 13 is required. Once connected as outlined above, the front panel CONTROL POWER switch will alternate latch on/latch off with each successive pressing of the switch. For local front panel command of the HIGH VOLTAGE OFF functionality a maintained connection between pin 14 and pin 15 is required.

REMOTE CONTROL – Remote control of CONTROL POWER, HIGH VOLTAGE ON and HIGH VOLTAGE OFF can be accomplished via the rear panel interface. The CONTROL POWER is an on-off toggle contact between pins 12 and 13. With the front panel CONTROL POWER switch latched in the “ON” position, opening and closing the connection between pins 12 and pins 13 will allow remote command of the CONTROL POWER functionality. HIGH VOLTAGE OFF and HIGH VOLTAGE ON are controlled by momentary normally closed; normally open contacts, respectively between pins 14 and 15, and pins 15 and 16. See Figure 3.4 for recommended interface.

EXTERNAL INHIBIT: The External inhibit allows the user to inhibit the power supply output without putting the power supply into the HIGH VOLTAGE OFF mode. This circuit can be used to generate fast slewing output waveforms. The maximum inhibit rate should not exceed 5Hz. Consult factory for higher repetition rates or high pulse load applications. See Figure 3.5 for the recommended interface circuit.

WARNING

IT IS EXTREMELY DANGEROUS TO USE THE EXTERNAL INHIBIT TO STOP HIGH VOLTAGE GENERATION FOR THE PURPOSE OF SERVICING OR APPROACHING ANY AREA OF THE LOAD CONSIDERED UNSAFE DURING HIGH VOLTAGE OPERATION

EXTERNAL INTERLOCK: The External Interlock connections are provided on the rear panel interface connector, pin 3 and pin 4, intended for use in the connection to a customer provided and implemented external safety switch. The unit will not enable into HIGH VOLTAGE ON unless the interlock circuit is closed. If the interlock is not being used (use is highly recommended), a jumper must be installed. During high voltage operation, opening the External Interlock will cause the unit to revert to the HIGH VOLTAGE OFF mode. Subsequent closing of the interlock circuit will NOT return the unit to HIGH VOLTAGE ON mode; this must be accomplished by depressing the HIGH VOLTAGE ON switch. See Figure 3.6 for the recommended interface circuit.

ARC DETECT/ARC QUENCH/ARC COUNT: The ARC Intervention Circuitry senses dynamic arcing or discharge conditions present at the output load with a wide bandwidth current transformer coupled to the return side of the high voltage multiplier.

The instant an arc is detected the generation of high voltage is electronically inhibited for 1 millisecond; this is called the ARC Quench time period. After the 1 millisecond period, the discharged high voltage output (level dependent upon arc impedance, arc duration, etc.) is ramped back up to the previous set level. This Arc ReRamp ramp time is 2 milliseconds. The ARC indicator on the front panel will illuminate for approximately 1 second after each arc has occurred. The HV INHIBIT indicator will also illuminate indicating that the output is being inhibited (ARC Quench).

The factory default Arc Count Shutdown setting of the Arc Intervention circuitry is such that if 25 arcs occur in a 5 second time period the unit will shut down into the POWER DOWN mode displaying an “ARC Fault”. This correlates to 5 arcs per second for a short timeframe. Additionally there is an Arc Rate Limiter feature. A real time averaging circuit will shut the power supply off with an ARC Fault if 50 arcs occur in a 30 second time period. This correlates to 1.67 arcs per second for a long time period. This allows the unit to operate in an arc prone environment, tolerating brief intense arcing but protect itself in the event of excessive long term arcing. ARC parameters can be modified by using the digital interface and provided GUI but changing these settings can have serious consequences.

NOTE: Making changes to the ARC Intervention Circuitry along with excessive arcing of the power supply can

thermally overheat and damage the internal short circuit limiting assembly. Damage to the power supplies internal short circuit limiting assembly is consider misuse of the unit and repairs will not be covered under the warranty. The ARC Intervention Circuitry is incorporated and configured to protect the power supply from excessive arcing, make changes to this circuitry at your own responsibility and risk.

3.3 Digital Interface (RS-232/Ethernet)

The EVA features standard RS-232 and Ethernet digital interface capability.

Note: The service connection to these units must be protected by an appropriately rated and

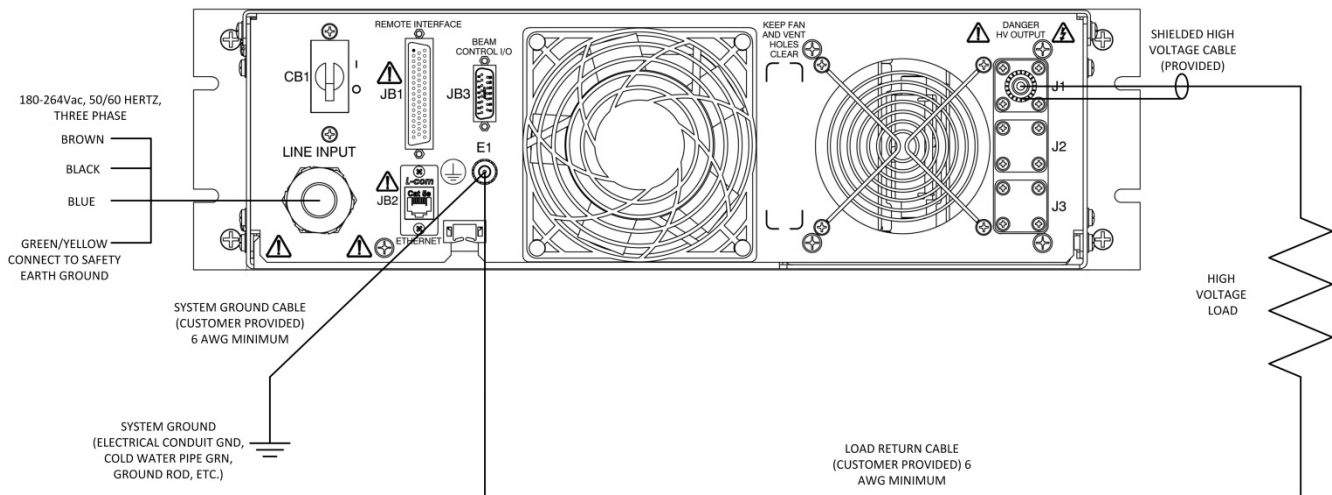

circuit breaker protected power connection.

Figure 3.1 Typical EVA Operating Setup

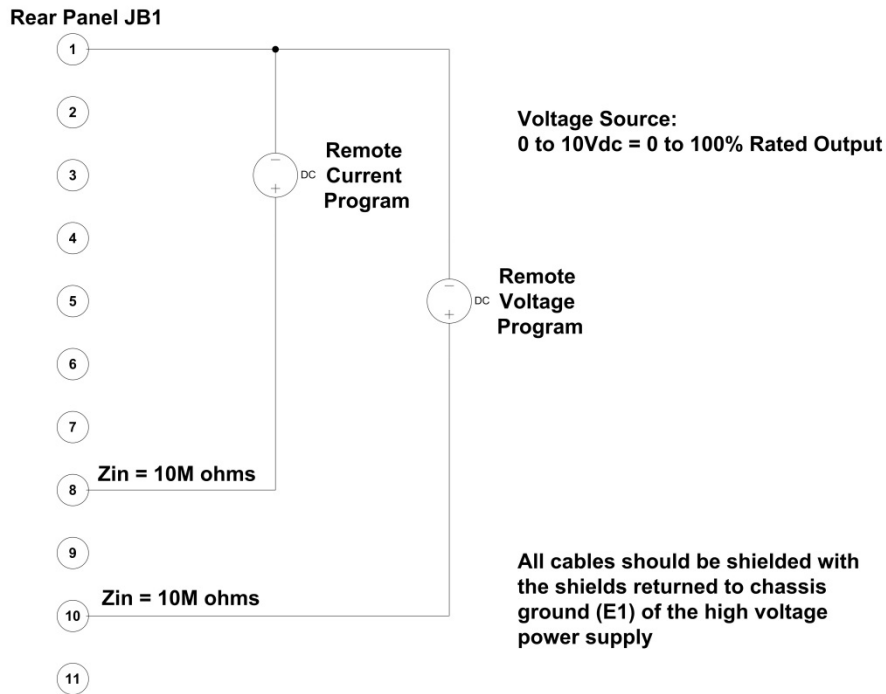

Figure 3.2A Wiring Diagram for Remote Programming via Voltage Source

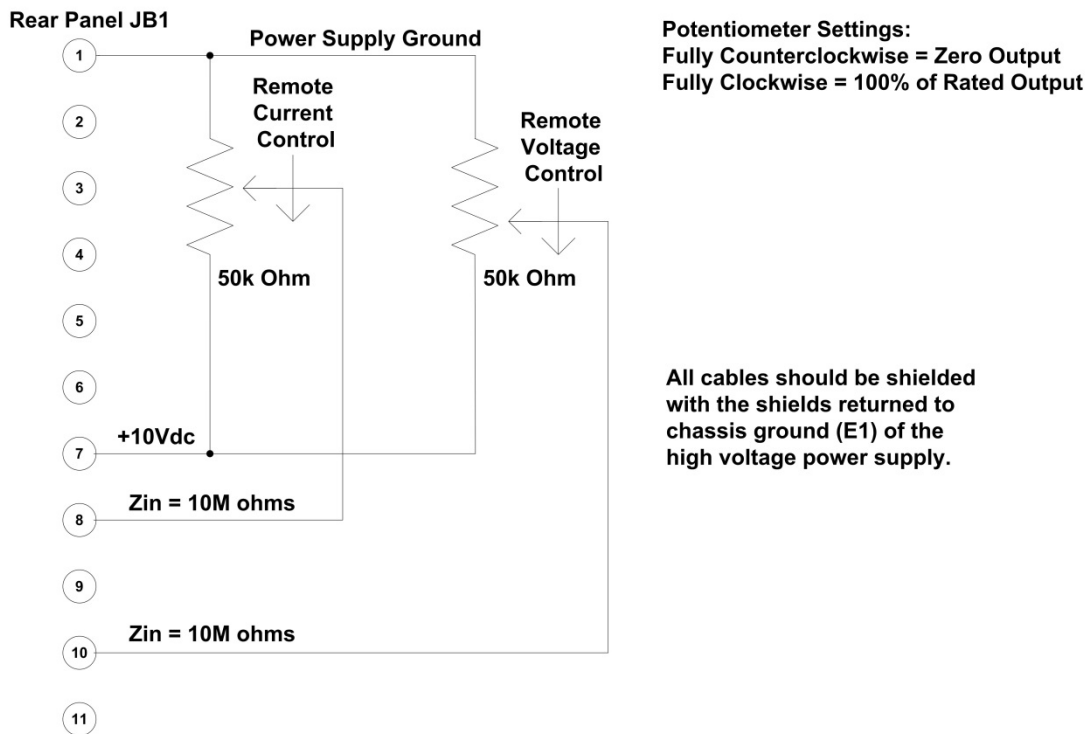

Figure 3.2B Wiring Diagram for Remote Programming via External Resistance

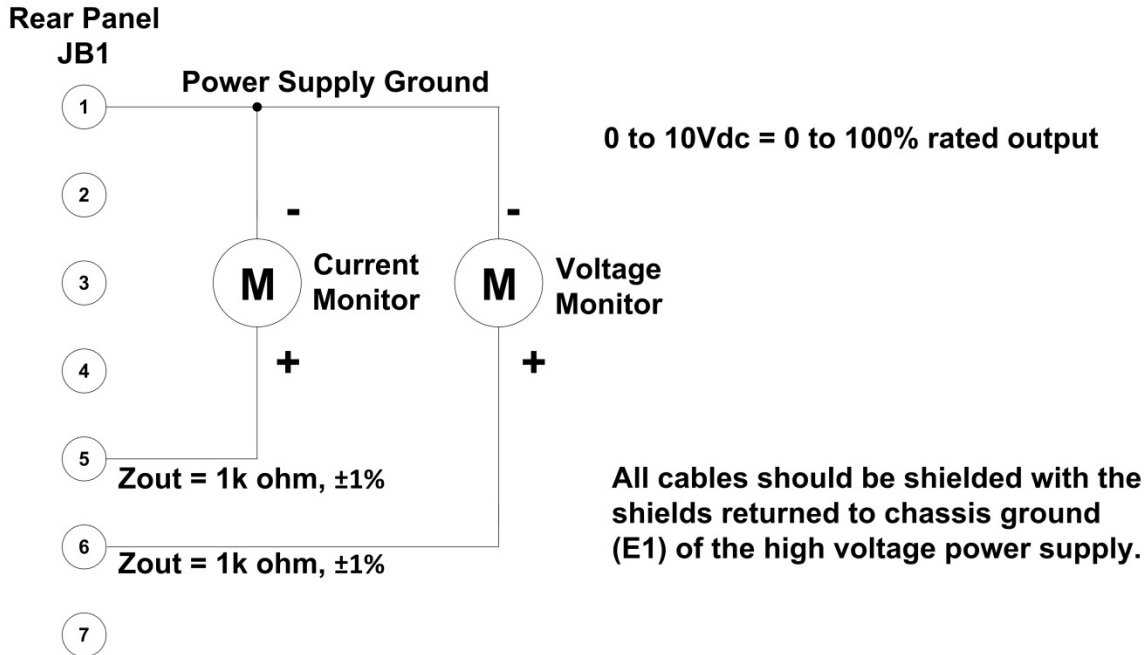

Figure 3.3 Remote Monitor Test Point Designations

It is recommended to use relay contacts for S1, S2 and S3. Relays should be located as close as possible to the high voltage power supply. Coils should be driven from isolated sources. Signals are at 24Vdc, 100mA max, and are only to be used for contact closure.

S1 must be closed to enable HIGH VOLTAGE ON.
Momentary closure of S2 will enable HIGH VOLTAGE ON.

Opening S1 will disable HIGH VOLTAGE ON and switch the unit to the HIGH VOLTAGE OFF mode.

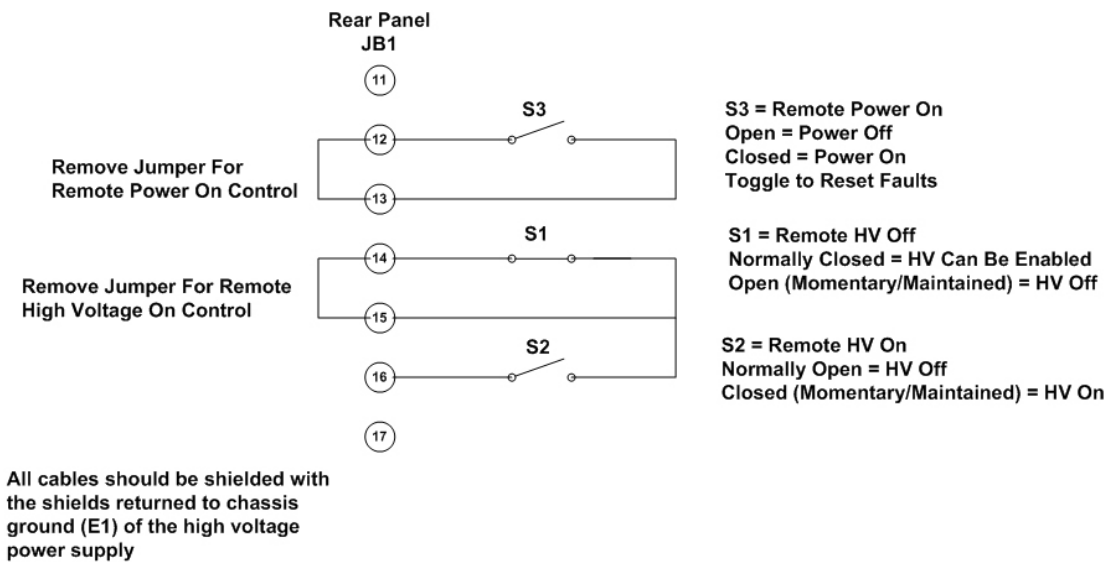
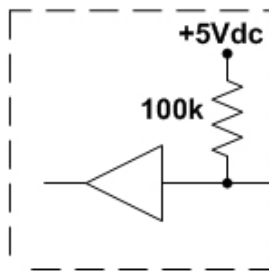
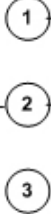

Figure 3.4 Remote Control of Power ON, High Voltage ON and High Voltage OFF

**High Voltage Power Supply
Inhibit Circuitry**



Rear Panel
JB1



Power Supply
Ground

Optocoupler should be located as close
as possible to the power supply

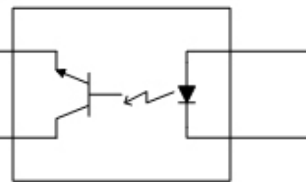

Active LED Current
Inhibits High Voltage

All cables should be shielded with
the shields returned to chassis
ground (E1) of the high voltage
power supply

Figure 3.5 External Inhibit Interface Circuit

Rear Panel
JB1



Customer provided relay
for control of External
Inhibit Circuit

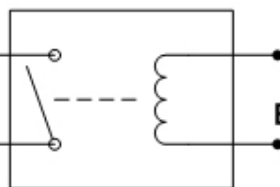

Relay Coil for Safety
External Interlock Control

It is recommended to use relay contacts
for the control of the External Interlock.
The relay should be located as close as
possible to the power supply. Signals are
 $\approx +24\text{Vdc}$ @ 100mA, maximum, and are
only to be used for contact closure.

All cables should be shielded with
the shields returned to chassis
ground (E1) of the high voltage
power supply

JB1-3 and JB1-4 @ Open = External Interlock Open, HV Disable, No HV Enable Possible
JB1-3 and JB1-4 @ Closed = External Interlock Closed, HV Can Be Enabled

Figure 3.6 External Interlock Interface Circuit

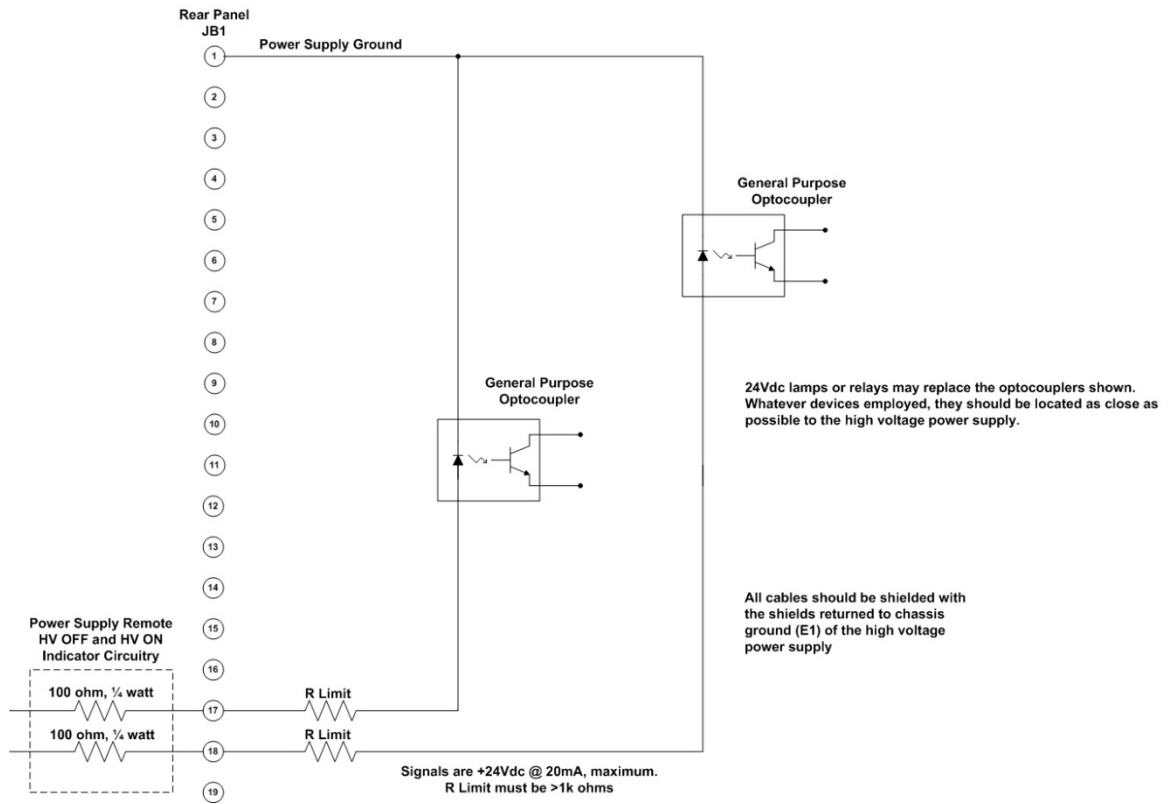

Figure 3.7 Remote High Voltage ON and Remote High Voltage OFF Indicator

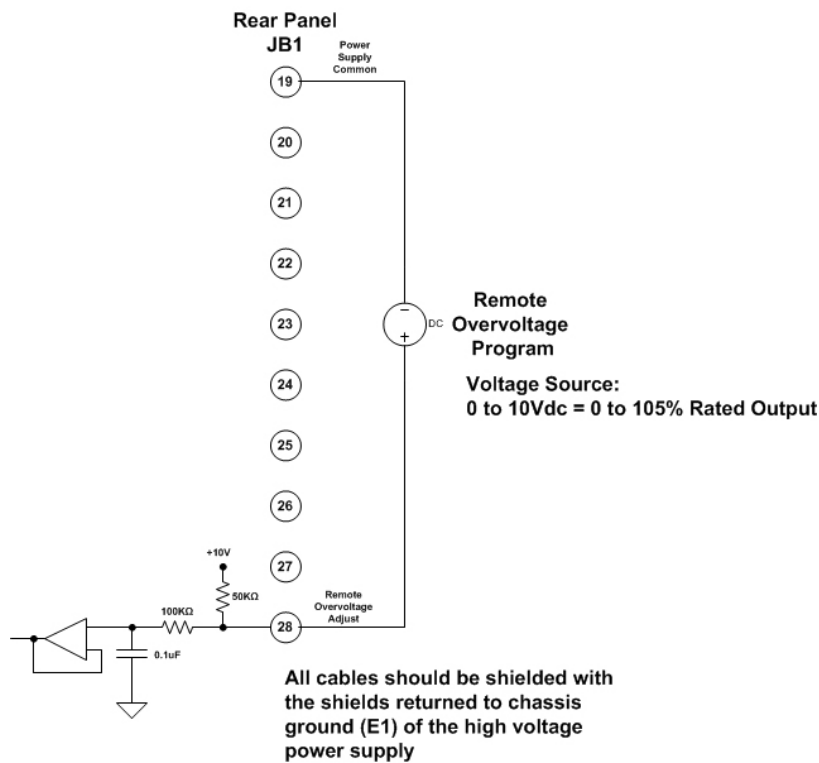

Figure 3.8 Remote Overvoltage Adjust Interface

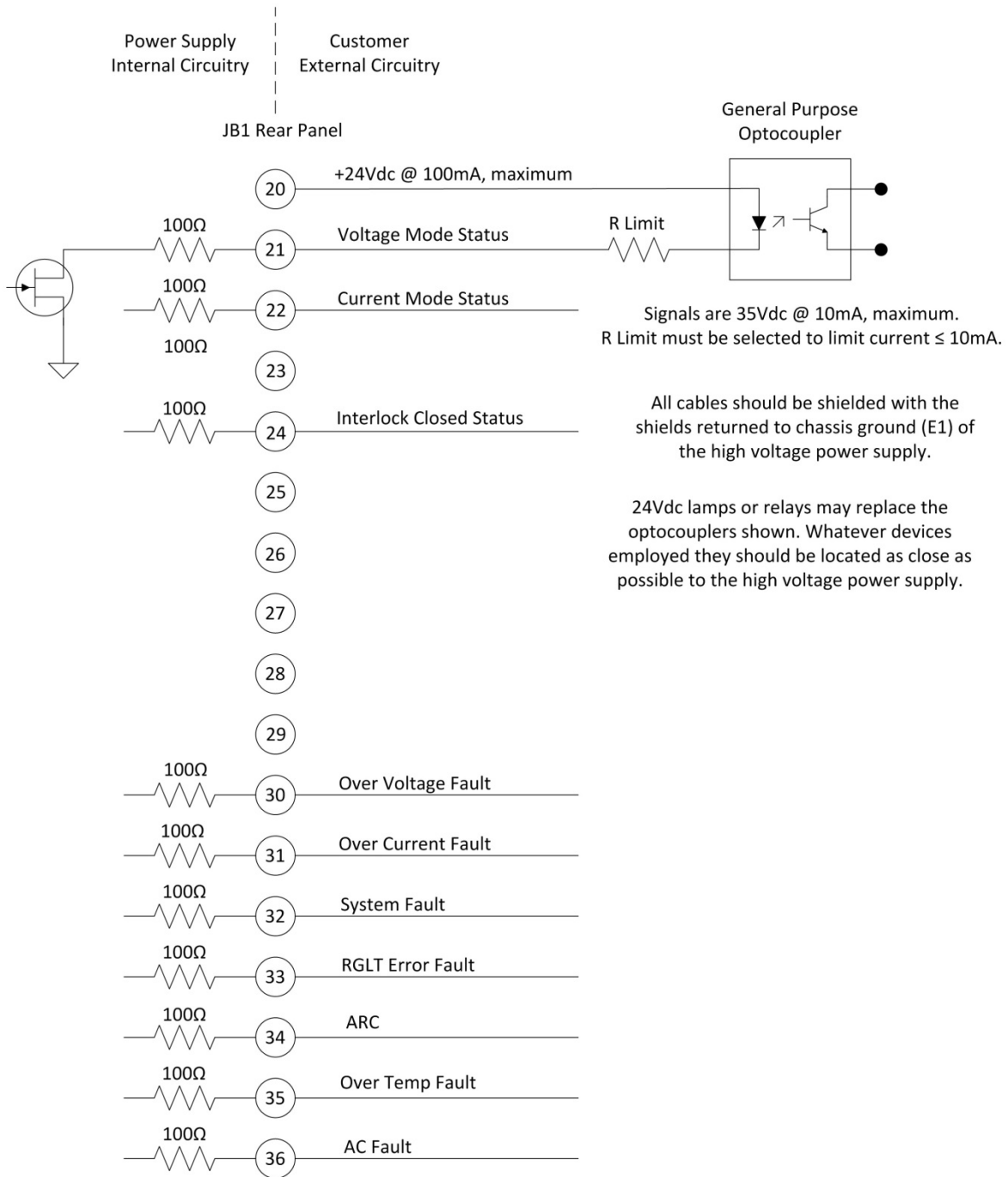

Figure 3.9 Remote Status and Fault Indicator Interface

Pin	Signal	Parameters
1	Power Supply Common	Power Supply Ground
2	Reset/HV Inhibit	Toggle to reset latched faults, Ground = Inhibit, Open = HIGH VOLTAGE ON
3	External Interlock	+24Vdc @ open, <25mA @ closed
4	External Interlock Return	Return for External Interlock. Pins 3 and 4 must be connected to HV enable
5	mA Test Point	0-10Vdc = 0-100% rated output, Zout = 1kΩ, 1%
6	kV Test Point	0-10Vdc = 0-100% rated output, Zout = 1kΩ, 1%
7	+10Vdc Reference	+10Vdc @ 1mA
8	mA Program Input	0-10Vdc = 0-100% rated output, Zin =>10MΩ, jump to pin 8 for local control
9	Local mA Program Output	0-10Vdc = 0-100% rated output, front panel potentiometer
10	kV Program Input	0-10Vdc = 0-100% rated output, Zin =>10MΩ, jump to pin 11 for local control
11	Local kV Program Output	0-10Vdc = 0-100% rated output, front panel potentiometer
12	Remote Power On Output	24Vdc @ open, <25mA @ closed
13	Remote Power On Return	Return for Remote Power On
14	Remote HV OFF	+24Vdc @ open, <25mA @ closed, connect to pin 15 for front panel operation
15	Remote HV OFF/ON Common	Remote HV OFF/ON Common
16	Remote HIGH VOLTAGE ON	+24Vdc @ open, <25mA @ closed, momentarily connect to pin 15 for HV enable
17	HIGH VOLTAGE OFF Indicator	+24Vdc @ 25mA = HV OFF
18	HIGH VOLTAGE ON Indicator	+24Vdc @ 25mA = HIGH VOLTAGE ON
19	Power Supply Common	Power Supply Ground
20	+24Vdc Output	+24Vdc @ 100mA, maximum
21	Voltage Mode Status	Open collector, Low = Active, 35V maximum @ 10mA
22	Current Mode Status	Open collector, Low = Active, 35V maximum @ 10mA
23	n/c	
24	Interlock Closed Status	Open collector, Low = Active, 35V maximum @ 10mA
25	n/c	
26	Spare	
27	Spare	
28	Remote Overvoltage Adjust	0-10Vdc = 0-105% rated output
29	n/c	
30	Over Voltage Fault	Open collector, Low = Active, 35V maximum @ 10mA
31	Over Current Fault	Open collector, Low = Active, 35V maximum @ 10mA
32	System Fault	Open collector, Low = Active, 35V maximum @ 10mA
33	RGLT Error Fault	Open collector, Low = Active, 35V maximum @ 10mA
34	ARC	Open collector, Low = Active, 35V maximum @ 10mA
35	Over Temp Fault	Open collector, Low = Active, 35V maximum @ 10mA
36	AC Fault	Open collector, Low = Active, 35V maximum @ 10mA
37	Spare	
38	Spare	
39	Spare	
40	Spare	
41	Spare	
42	Short to pin 43	Connect pin 42 and pin 43 together in all configurations
43	Short to pin 42	Connect pin 42 and pin 43 together in all configurations
44	+5Vdc Output	+5Vdc @ 100mA, maximum
45	+15Vdc Output	+15Vdc @ 100mA, maximum
46	-15Vdc Output	-15Vdc @ 10mA, maximum
47	RS-232 Tx	RS-232 Tx
48	RS-232 Rx	RS-232 Rx
49	RS-232 GND	RS-232 GND
50	Power Supply Common	Power Supply Ground

☐ = Denotes jumper connection for simplified local front panel control

Figure 3.10 JB1 Rear Panel Interface Connector

Chapter 4

EVA HIGH VOLTAGE POWER SUPPLY PRINCIPLES OF OPERATION

The EVA series of high voltage power supplies utilizes sophisticated power conversion technology. A variety of analog, digital and power conversion techniques are employed. This Principles of Operation will introduce the basic function blocks that comprise the EVA power supply. For details on a specific circuit, consult Spellman's Engineering Department.

The EVA power supply is an AC to DC converter. Within the power supply, conversions of AC to DC, high frequency AC, then to high voltage DC take place. By reviewing functionality of the subassemblies, a basic understanding of the process can be gained.

WARNING

THE ENERGY LEVELS USED AND GENERATED BY THE POWER SUPPLY CAN BE LETHAL! DO NOT ATTEMPT TO OPERATE THE POWER SUPPLY UNLESS THE USER HAS A SUFFICIENT KNOWLEDGE OF THE DANGERS AND HAZARDS OF WORKING WITH HIGH VOLTAGE. DO NOT ATTEMPT TO APPROACH OR TOUCH ANY INTERNAL OR EXTERNAL CIRCUITS OR COMPONENTS THAT ARE CONNECTED OR HAVE BEEN CONNECTED TO THE POWER SUPPLY. BE CERTAIN TO DISCHARGE ANY STORED ENERGY THAT MAY BE PRESENT BEFORE AND AFTER THE POWER SUPPLY IS USED. CONSULT [IEEE RECOMMENDED PRACTICES FOR SAFETY IN HIGH VOLTAGE TESTING #510-1983](#).

4.1 Line Rectification and Filtering

WARNING

LINE VOLTAGE IS PRESENT WHENEVER THE POWER SUPPLY IS CONNECTED TO THE INPUT LINE VOLTAGE. BE SURE TO DISCONNECT THE LINE CORD BEFORE OPENING THE UNIT. ALLOW 5 MINUTES FOR INTERNAL CAPACITANCE TO DISCHARGE BEFORE TOUCHING ANYTHING CONNECTED TO LINE REFERENCED CIRCUITRY.

Simple three/single phase rectification provides the DC buss voltage for the high frequency inverter.

An input line cord, circuit breaker, EMI Filter Assembly, contactor, inrush limiting circuitry, bridge rectifier, electrolytic capacitors, rail inductors and rail capacitors comprise the basic components required for input line rectification.

Three different input voltages are available for the EVA Series. If the user is unsure which input voltage is required for the unit on hand, check the identification tag on the rear of the power supply.

The customer provided AC power input is provided to the unit via the four conductor AC line cord. Circuit protection is provided by CB1, a fast acting magnetic trip type circuit breaker. The load side of CB1 is connected to EMI filter A2. The output of the EMI filter connects to K1, a three phase contactor. K1 provides fail-safe type disconnection of the line voltage to the power supply rectification circuits. K1's coil is controlled by a variety of circuit conditions, which will be described later on. The load side of CB1 is also connected to low voltage power supply assembly A9, which provides various voltages for housekeeping and control circuit power.

When contactor K1 is energized, voltage is applied to isolated bridge rectifier power module CR1, used for line voltage rectification. The output of CR1 is connected to aluminum electrolytic capacitors C1 and C2 for line filtering purposes. Capacitors C1 and C2 are initially charged through inrush limiting charging resistors which is located on POWER PWB – A6.

After an appropriate period of time to charge C1 and C2, relays on POWER PWB – A6 are energized to short out the inrush limiting resistors. The generated DC buss voltage is supplied to the inverter circuitry through L2, L3, L6 and L7. The inductors provide isolation for the electrolytic capacitors C1 and C2, so the inverter's high

frequency pulse currents are drawn from the metalized film high frequency “rail capacitors” C3 and C12.

The POWER PWB – A6 provides the inrush limiting function via R1, R2, R3 and R4. Relays K1 and K2 short out the limiting resistors once the initial charging of C1 and C2 is complete. Resistors R7, R8, and R10, R11 form two feedback divider circuits with terminating resistors located on the SYSTEM CONTROL PWB – A1. These impedance limited, low voltage + and – rail feedback signals are monitored and if any abnormal conditions appear, circuitry will shut down the power supply.

Typically a SYSTEM FAULT and AC FAULT indication will appear on the front panel if an error in the charging circuits has occurred.

R5 on the POWER PWB – A6 functions as a bleeder resistor, which is used to discharge the front end filter capacitors C1 and C2. DS1 provides visual indication when DC voltage is present. This indicator should not be relied on for confirming the presence or absence of the DC voltage in any situation where user safety is of concern.

4.2 Inverter

The inverter employs a proprietary, quasi-resonant, pulse width modulated topology. L1 and L5 are the resonating inductors. Q1, Q2 Q3 and Q4 are high speed IGBT isolated power modules. These devices provide high frequency switching capability to control the flow of current through the primary of the high voltage step up transformers. The gate control for the switching devices is provided by GATE DRIVE PWB A3 and A4. The control signals are generated by the SYSTEM CONTROL PWB – A1.

4.3 High Voltage Transformer

The output of the Inverter is connected to the primary of the High Voltage Transformer. The High Voltage Transformer is a step-up type. Typical secondary voltages are in the range of 1kVac to 5kVac depending upon the units specific maximum output voltage rating.

4.4 High Voltage Assembly

The High Voltage Assembly will vary depending upon the model ordered. The circuitry typically consists of full wave doubler output circuit.

Output filtering is typically provided by an L-C type filter. Voltage feedback for regulation and monitoring is provided by a high bandwidth resistive/capacitive compensated feedback divider. Current feedback for regulation and monitoring is provided by a sense resistor connected at the low voltage end of the high voltage output section.

4.5 System Control PWB

The majority of control circuits for power supply controls are located on the SYSTEM CONTROL PWB – A1. For trouble shooting and testing purposes, this board can be easily accessed by removing the screws located on the side panels near the front panel. The front panel will hinge down allowing for easy access to the SYSTEM CONTROL PWB

4.6 Front Panel Assembly

Front Panel CONTROL POWER, HIGH VOLTAGE OFF, HIGH VOLTAGE ON, switches, voltage programming potentiometer, voltage and current digital meters, and status indications are connected to the FRONT PANEL PWB. – A7. The FRONT PANEL PWB interfaces directly to the SYSTEM CONTROL PWB - A1.

Chapter 5

EVA HIGH VOLTAGE POWER SUPPLY INPUT VOLTAGE & OPTIONS

The input voltage and options available for this power supply are described in this section. An input voltage selection must be made at time of order for each EVA high voltage power supply. Options are specified by including the option code in the model number as described in Section 1.5.

5.1 180-264Vac, 3Ø Input - 3PH

This factory configures EVA units to operate from 180-264Vac, three phase, 50/60Hz input power. Available on 3kW, 6kW and 12kW units.

5.2 180-264Vac, 1Ø Input - 1PH

This option factory configures EVA units to operate from 180-264Vac, single phase, 50/60Hz input power. Available only on 3kW and 6kW units.

5.3 360-528Vac Input - 400VAC

This option factory configures the EVA units to operate from 360-528Vac, three phase, 50/60Hz input power. Available only on 12kW units.

5.4 High Voltage Cable Length - LL(X)

Custom length high voltage output cables, indicated in foot measurement units. Various predetermined lengths are available along with entirely custom lengths; contact Spellman Sales Department for details.

5.5 Two High Voltage Connectors - HV2

Optional two (2) high voltage output connectors that are connected in parallel for powering two beam channels with a single high voltage power supply.

5.6 Three High Voltage Connectors - HV3

Optional three (3) high voltage output connectors that are connected in parallel for powering three beam channels with a single high voltage power supply.

5.7 Filament Gun Supply, 1 Channel- FIL1

Optional beam controller (filament supply) and gun output box for single channel applications.

5.8 Filament Gun Supply, 2 Channel- FIL2

Optional beam controller (filament supplies) and gun output boxes for two channel applications.

5.9 Filament Gun Supply, 3 Channel- FIL3

Optional beam controller (filament supplies) and gun output boxes for three channel applications.

5.10 High Power Filament - HPF

50 amp filament power supply.

5.11 Custom Designed Models - X(#)

Units built to customer specifications are assigned an X number by the factory. If this unit is an X model, a specification control sheet is added at the end of this instructional manual. Spellman welcomes the opportunity to tailor units to fit your requirements or to develop new products for your applications. Contact the Spellman Sales Department with your need.

Chapter 6

EVA BEAM CONTROLLER INTRODUCTION

6.1 Description of Beam Controller (Filament Power Supply)



Multiple beam control units can be provided, allowing 1, 2 or 3 separate electron guns to be independently operated from a single EVA high voltage power supply. Each beam control unit consists of a beam controller and a gun output box. The beam controller is a 1U (1.75"/44.45mm) rack-mounted chassis containing the filament power, control and emission (beam) current regulation circuitry. The gun output box contains the high frequency filament transformer which is referenced to the high voltage output potential. This box should be mounted close to the electron gun to minimize the length of the high current filament connections. The box also contains emission (beam) current monitoring circuitry and provides a feedback signal used to regulate the emission (beam) current.

Each beam control channel if operated alone can utilize 0 to 100% of the rated emission current capacity of the EVA high voltage power supply. When two or three beam control channels are used at the same time, the total system emission current capacity remains the same. Individual channel programming must be done such that the total current does not exceed the systems total emission current available.

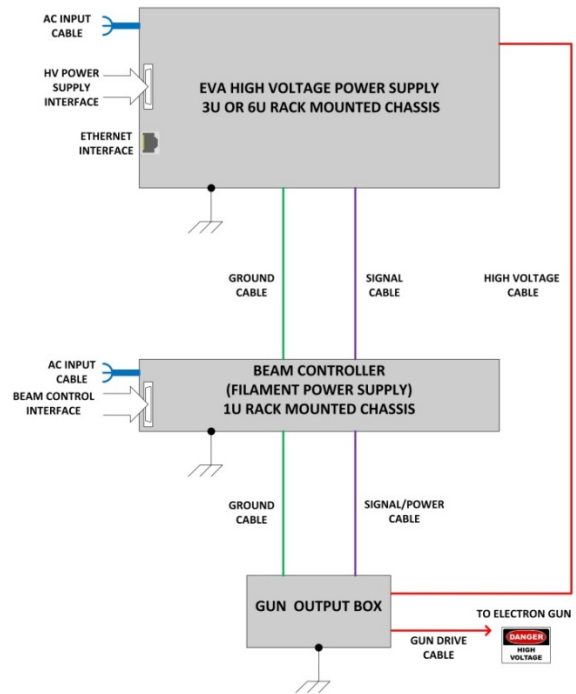

Figure 6.1 EVA System Block Diagram

6.2 Standard Features

The beam controller incorporates several standard features designed to optimize user utility, satisfaction and safety.

FRONT PANEL BEAM OFF/ BEAM ON SWITCHES: These intuitive front panel controls allow the user to easily enable/disable the generation of the electron beam.

FRONT PANEL INDICATOR LAMPS: BEAM ON and BEAM OFF indicators are integral with the control switches and are LED illuminated for reliability and long service life.

FRONT PANEL POTENTIOMETERS: A ten turn potentiometer is provided for easy programming of the desired emission (beam) current value. Additionally a

single turn potentiometer is provided for the Filament Limit Set value.

FRONT PANEL DIGITAL METERS: 3.5 digit meters are provided to view the Emission (Beam) Current, Filament Limit Set value and Filament Operating Current. A convenient Preset View Feature is provided: If the BEAM OFF button is depressed and held in, the emission (beam) current programming value will be displayed in mA on the right front panel meter. Additionally when the BEAM OFF button is depressed and held in, the Filament Limit Set value will be displayed in amps on the left front panel meter. When in the active BEAM ON condition this meter displays the operational filament current value.

INTERNAL FAULT PROTECTION: The beam controller continually monitors internal circuits critical to its operation. If one of these circuits malfunctions, the fault detection circuit turns off the emission (beam) current and reverts the unit to the POWER DOWN mode, where neither the BEAM ON nor the BEAM OFF indicator lamps will be illuminated. The applicable fault indicator will be illuminated on the fault diagnostic panel, requiring the user to clear (depress the BEAM OFF switch, or cycle the AC line power) before the emission (beam) current can be re-enabled.

6.3 Remote Operating Features

REMOTE PROGRAMMING: Allows remote adjustment of the Emission (beam) Current, Filament PreHeat and Filament Limit Set parameters via the use of 0-10Vdc = 0-100% rated, external voltage sources.

REMOTE MONITOR: Allows remote monitoring of the 0-10Vdc = 0-100% rated, Emission (beam) Current and Filament Current test points.

REMOTE BEAM ON/OFF CONTROL: Allows remote control of the BEAM ON and BEAM OFF functions via dry contact opens and closures. Signals are also provided for remote indication of BEAM ON and BEAM OFF status.

EXTERNAL INTERLOCK: Interlock connections are provided on the rear panel interface connector for connection to a safety switch. The unit will not operate

unless the interlock circuit is closed. During operation, opening the interlock circuit will cause the BEAM ON to shut off. This circuit should be used for safety interlock circuits. Spellman strongly recommends the use of External Interlocking for safety purposes.

6.4 System Status and Fault Diagnostic Display

“Dead Front” backlight type indicators provide system operation and fault condition information. If a fault occurs the beam controller will revert to the POWER DOWN mode. This is indicated by the BEAM ON and the BEAM OFF indicator lamps both **not** being illuminated. The applicable fault indicator will be illuminated on the front panel requiring the user to clear (depress the BEAM OFF switch, or cycle the AC line power) before the beam can be re-enabled.

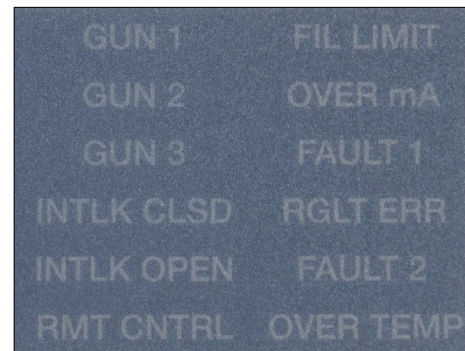

GUN 1: Indicates a beam controller is active in the Channel One position.

GUN 2: Indicates a beam controller is active in the Channel Two position.

GUN 3: Indicates a beam controller is active in the Channel Three position.

INTLK CLOSED: Indicates the EXTERNAL INTERLOCK connections are in the closed position.

INTLK OPEN: Indicates the EXTERNAL INTERLOCK connections are in the open position. This also indicates opening of internal power supply interlocks. It is not possible to enable BEAM ON with an open EXTERNAL INTERLOCK.

RMT CNTRL: Indicates that the programming of the unit is being accomplished by either the Ethernet or RS-232 digital interface. This feature is selectable via the rear panel DIP switch, switch position 1. See the section on Configuration for more details.

FIL LIMIT: Indicates that the beam controller is limiting the filament current at the programmed Filament Current Limit level.

OVER mA: Indicates the emission (beam) current has been actively limited to 105% of maximum rated current (as per an internal printed circuit board potentiometer setting).

FAULT 1: Not allocated.

RGLT ERR: Indicates a failure in the beam controllers regulation circuitry. This fault usually occurs when there is a lack of output power to maintain proper output regulation. Possible causes could be due to low AC input voltage (below low line parameters) or a malfunction of the power supply preventing it from generating the voltage/current being requested.

FAULT 2: Not allocated.

OVER TEMP: Indicates that excessive temperature has been sensed within the chassis and internal protection circuitry has shut down the beam controller.

6.5 Options

HPF High Power Filament

This option provides a 50 amp filament capable beam controller and gun output box.

BEAM CONTROLLER INSPECTION, INSTALLATION AND CONFIGURATION

Initial inspection and preliminary checkout procedures are recommended. For safe operation, please follow the step-by-step procedures described in section 6.10, Operating Instructions.

6.6 Initial Inspection

Inspect the package exterior for evidence of damage due to handling in transit. Notify the carrier and

Spellman immediately if damage is evident. Do not destroy or discard any of the packing material used in a damaged shipment. After unpacking, inspect the panel, chassis, gun output box and cables for visible damage.

Standard Spellman EVA beam controllers are covered by a warranty. Custom and special order models (with a unique 4 digit X suffix in the model number) are also covered by a warranty. Check the specific warranty terms by referring to the Warranty document contained in this operator's manual.

6.7 Input Requirements

Each beam controller chassis operates from 180-264Vac, 50/60Hz, single phase, 7.5 amps maximum (10 amps maximum for HPF Option - 50 amp units).

Beam controller chassis have front panel holes for standard EIA rack mounting. The rack must allow rear mechanical installation access for cable connections. Units are fully enclosed and are suitable for bench or tabletop operation. It is strongly recommended to support the chassis by guides or shelves.

6.8 Airflow Requirements

Beam controllers are forced air cooled, air enters the chassis via openings on the right and left side panels and air is forcibly exhausted out the rear panel via a single fan. Whatever mechanical installation is implemented airflow into and out of the unit must not be compromised. Additionally it is the responsibility of the user to assure that air entering the unit is not above the maximum ambient temperature of 40°C. Airflow volume is 25cfm.

6.9 Configuration

Multiple beam control units can be provided, allowing 1, 2 or 3 separate electron guns to be independently operated. A rear panel accessible DIP switch configures each chassis for use in single channel or multi-channel applications. If a complete system is ordered from the factory, this configuration setting will already be done. If you are reconfiguring an existing system, or adding a beam control unit in the field the details of the configuration process are outlined below.

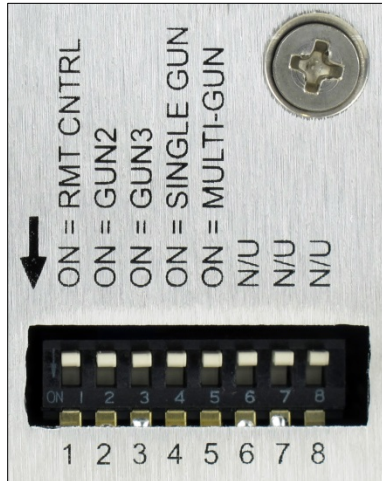

Switch	Name	Programming Feature	Switch Position ON	Switch Position OFF
1	RMT CNTRL	Enables remote control via the provided Ethernet/RS-232 interfaces.	ON(down) for RMT CNTRL	OFF(up) for local control and remote analog control
2	GUN2	Configures the Beam Controller chassis as GUN2. Lights up the front panel GUN2 lamp. (See Note 1)	ON(down) for GUN2	OFF(up) for Single Gun and for GUN1 and GUN3 in Multi-Gun configuration
3	GUN3	Configures the Beam Controller chassis as GUN3. Lights up the front panel GUN3 lamp. (See Note 1)	ON(down) for GUN3	OFF(up) for Single Gun and for GUN1 and GUN2 in Multi-Gun configuration
4	SINGLE GUN	Selects the Emission Current feedback signal from the EVA High Voltage Chassis. For single gun configuration only.	ON(down) No GUN2 or GUN3 installed	OFF(up) for Multi-Gun configuration
5	MULTI-GUN	Selects the Emission Current feedback signal from the Gun Output Box when multiple guns are installed.	ON(down) on GUN1, GUN2, GUN3	OFF(up) for Single Gun Configuration
6	n/u			
7	n/u			
8	n/u			

Note1: The Beam Controller chassis is configured as GUN1 when the GUN2 and GUN3 selector switches are both in the OFF (up) position. The GUN1 front panel lamp will illuminate.

Table 6.1 Rear Panel DIP Switch Configuration

EVA BEAM CONTROLLER OPERATING INSTRUCTIONS

6.10 Operation

WARNING

THIS EQUIPMENT'S OUTPUT IS REFERENCED TO DANGEROUS VOLTAGES THAT MAY BE FATAL. PROPER GROUNDING OF ALL HIGH VOLTAGE EQUIPMENT IS ESSENTIAL.

WARNING

BEFORE CONNECTING THE POWER SUPPLY TO THE AC LINE, FOLLOW THIS STEP-BY-STEP PROCEDURE.

DO NOT CONNECT THE POWER SUPPLY TO THE AC LINE UNTIL STEP 'G' IS REACHED. FAILURE TO FOLLOW THESE PROCEDURES MAY VOID THE WARRANTY.

- A) Insure that the input power cable is disconnected from the rear panel IEC320 connector.
- B) Check the input voltage rating on the rear panel identification tag and make certain that this is the rating of the available power source.
- C) **PROPER GROUNDING TECHNIQUE:** The chassis of the high beam controller and the gun output box must be properly grounded. Connect the ground cable from the gun output box to the beam controller using the ¼-20 ground studs. Connect the ground cable from the beam controller to the EVA high voltage power supply using the ¼-20 ground studs. See Figure 6.2 for a typical operating setup.

A six foot long, detachable IEC320, three-wire, unterminated line cord is provided for connecting to the AC input supply. The BROWN wire is LINE and the BLUE wire is NEUTRAL. The GREEN wire is for chassis safety ground connection. This is a safety ground connection and is NOT adequate for system grounding purposes.

MAKE CERTAIN THE EVA HIGH VOLTAGE POWER SUPPLY IS DISCONNECTED FROM THE AC POWER

SOURCE AND TURNED OFF FOR A MINIMUM OF 5 MINUTES BEFORE PROCEEDING!

- D) Plug the captive (yet field replaceable) high voltage output cable attached to the gun output box into the rear panel high voltage connector of the EVA high voltage power supply and secure properly.
- E) Connect the captive two conductor filament output cable that exits the gun output box to the filament of the electron gun. Either wire can be connected to which ever terminal of the filament desired as there is no polarity orientation. Make certain the connections are secure due to the high current output (35 amp standard or optional 50 amp) of the filament power supply.
- F) For initial turn-on, rotate the front panel Emission (beam) Current control potentiometer fully counter-clockwise to the zero position. Rotate the front panel Filament Limit Set control potentiometer fully counter-clockwise to the zero position.
- G) The input power cable may now be connected to the AC power line.
- H) Reconnect the AC power source to the EVA high voltage power supply and the EVA beam controller.
- I) Depress the CONTROL POWER ON switch on the EVA high voltage power supply front panel.
- J) Observe that the front panel meters are illuminated and the green BEAM OFF indicator is illuminated on the EVA beam controller chassis. Additionally observe that the front panel meters are illuminated and the green HIGH VOLTAGE OFF indicator is illuminated on the EVA high voltage power supply chassis.
- K) Rotate the Filament Limit potentiometer slowly clockwise until the beam controller filament current meter displays the factory preset 10 amp preheat level. The filament is now operating at a 10 amp filament current level.
- L) Depress and hold in the BEAM OFF switch. The front panel meters will now display the preset value of the Emission (beam) Current control potentiometer and the Filament Limit Set control potentiometer. To preset

the desired level of the Emission (beam) Current and Filament Limit Set continue holding in the BEAM OFF switch and rotate the applicable control dial while noting its corresponding meter reading. Release the BEAM OFF switch.

NOTE: No actual electron beam is being produced at this time, but the filament is operating at the preheat current levels.

M) Depress the HV ON switch on the EVA high voltage power supply. The red light inside the switch should illuminate and the output will slowly start up to the preset level output voltage under a no load current condition.

NOTE: The EVA series is equipped with a slow start circuit that ramps the output up to its maximum setting in approximately 6 seconds after the HV ON switch is depressed.

N) Depress the BEAM ON switch on the beam controller. The red light inside the switch should illuminate and the emission (beam) current will slowly start up to the preset level, as displayed on the front panel digital display.

O) To terminate the generation of electron beam, depress the BEAM OFF switch on the beam controller. In the BEAM OFF mode the beam controllers fault and interface circuits are still active and the filament is operating at the 10 amp preheat level. The high voltage is still operating at the present voltage level.

P) To turn off the EVA high voltage power supply, depress the HV OFF switch on the EVA high voltage power supply. In the HV OFF mode the EVA high voltage power supplies fault and interface circuits are still active. To fully turn off the EVA high voltage power supply and EVA beam controller push in CONTROL POWER ON switch to release the switch bezel to the out position. All front panel lights should extinguish.

NOTE: If a beam controller fault, or system monitoring fault occurs, the beam controller will revert to the POWER DOWN mode. This is indicated by neither the BEAM ON nor the BEAM OFF indicator lamps will be illuminated. The EVA high voltage power supply will shut down with a "GUN" fault and the CONTROL POWER ON

lamp will flash. The applicable fault indicator will be illuminated on the front panel requiring the user to clear (depress the BEAM OFF switch, or cycle the AC line power). The EVA high voltage power supply fault is cleared by cycling the CONTROL POWER ON switch, cycling the AC line power or by toggling the Reset/HV Inhibit (50 pin connector pin 2) signal line.

WARNING

AFTER TURN OFF, DO NOT HANDLE THE OUTPUT UNTIL THE CAPACITANCE HAS BEEN DISCHARGED! LOAD CAPACITANCE MAY BE DISCHARGED BY SHORTING TO GROUND.

WARNING

DANGER - THE VOLTMETER ON THE EVA HIGH VOLTAGE POWER SUPPLY FRONT PANEL DOES NOT DISPLAY THE OUTPUT VOLTAGE WHEN THE POWER IS TURNED OFF, EVEN IF A CHARGE STILL EXISTS ON THE OUTPUT.

CAUTION

TO ASSURE SAFETY AND PROPER COOLING ALWAYS OPERATE THE UNIT WITH THE TOP COVER INSTALLED.

A fan maintains safe operating temperatures in the beam controller by drawing air over the circuit components. The cover must be on in order to direct the air flow over the areas that need cooling. In operation, the units air intake and fan exhaust paths must be clear of any obstructions that might impede the flow of air.

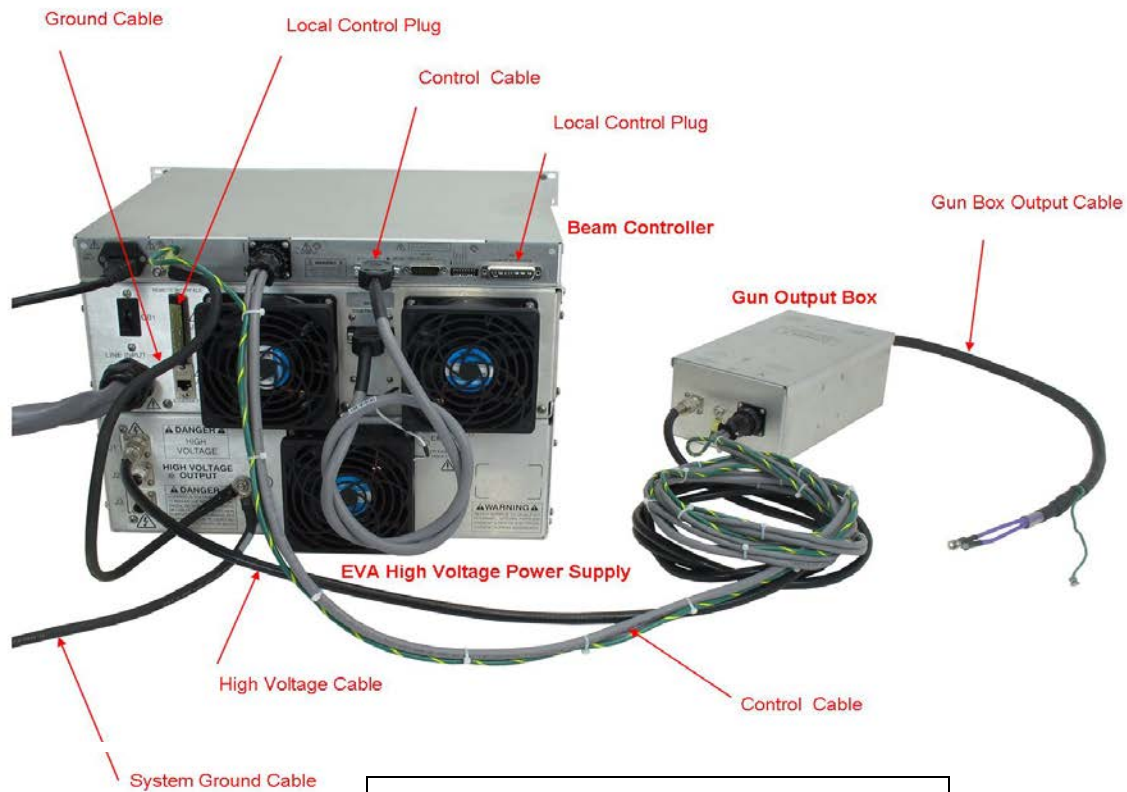

Figure 6.2 Typical Operating Setup

6.11 Standard Features

A general note on remote interface circuitry and remote signal grounding:

When usage applications dictate, electrical isolation may be required when interfacing with beam controller in question. For power control signals such as EXTERNAL INTERLOCK, BEAM OFF and BEAM ON, isolated relay contacts should be used. For status signals and control signals such as BEAM ON, BEAM OFF, etc. opto-isolation should be used. When usage applications dictate, analog programming and monitoring signals may require isolation via analog isolation amplifiers. All interface cables should be properly shielded. All power supply signals should be referenced to the power supplies signal ground on the rear panel interface connector.

LOCAL/REMOTE PROGRAMMING: Allows adjustment of the Emission (beam) Current, Filament Limit Set and Filament Preheat via the front panel/internal controls (local) or external voltage sources (remote).

LOCAL CONTROL - Local programming (front panel/internal control) will enable the front panel potentiometers for Emission (beam) Current and Filament Limit Set, and an internal factory preset potentiometer to set the Filament PreHeat. This is accomplished by setting the rear panel DIP switch, switch 1 position to the OFF (up) position. A jumper should be placed between the rear panel 25 pin female D connector pins 8/9, pins 10/11 and pins 12/13 to enable local Filament Limit Set, Beam Current Program and Filament Preheat control respectively.

REMOTE CONTROL - For remote programming a positive polarity, ground referenced 0-10Vdc source is applied to the rear panel 25 pin female D connector pin 8, pin 10 and pin 12 for Filament Limit Set, Beam Current Program and Filament Preheat control respectively. Any jumpers for local control should be removed and the programming signals should be referenced to pin 1, signal ground. See Figure 6.3 for more details.

An alternate method of controlling the output remotely is by using external resistance such as a potentiometer or a resistor network. See Figure 6.4 for more details.

REMOTE MONITORS: Test points (monitors) are made available on the rear panel interface connector for monitoring the Emission (beam) Current and Filament Current; pin 6 and pin 5 respectively. The test points are always positive, scaling is such that 0-10Vdc corresponds to 0-100% rated output. Test points have an output impedance of 4.99k ohms, $\pm 1\%$. See Figure 6.5 for more information.

LOCAL/REMOTE: BEAM ON/BEAM OFF: Allows for command of BEAM ON and BEAM OFF by either the front panel controls or external signals via the rear panel 25 pin external interface connector.

LOCAL CONTROL - For local front panel command of the BEAM OFF functionality a maintained connection between pin 14 and pin 15 is required.

REMOTE CONTROL – Remote control of BEAM ON and BEAM OFF can be accomplished via the rear panel

interface. BEAM OFF and BEAM ON are controlled by momentary normally closed; normally open contacts, respectively between pins 14 and 15, and pins 15 and 16. See Figure 6.6 for more details.

EXTERNAL INTERLOCK: The External Interlock connections are provided on the rear panel interface connector, pin 3 and pin 4. They are intended for use in the connection to a customer provided and implemented external safety switch. The unit will not operate unless the external interlock circuit is closed. If the interlock is not being used (use is highly recommended), a jumper must be installed. During operation, opening the external interlock will cause the unit to revert to the BEAM OFF mode. Subsequent closing of the interlock circuit will NOT return the unit to BEAM ON mode; this must be accomplished by depressing the BEAM ON switch (be it local or remote). See Figure 6.7 for more details.

REMOTE BEAM ON/OFF INDICATORS: Allows for the remote monitoring of BEAM ON/OFF. See Figure 6.8

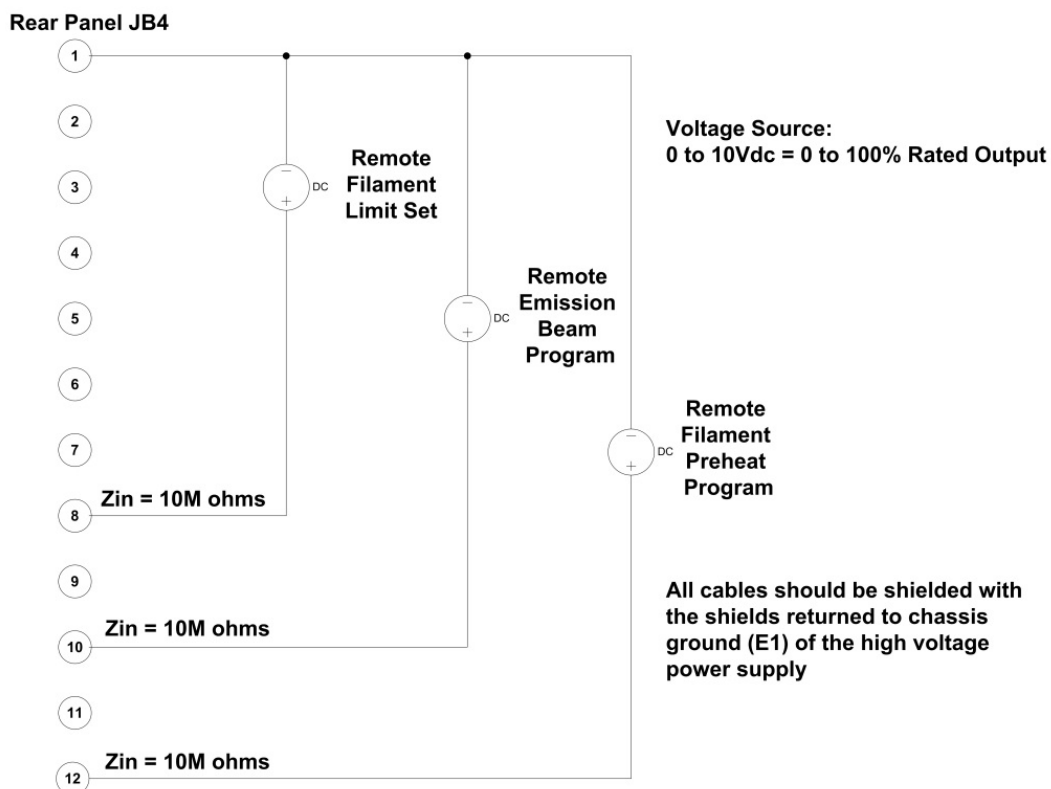

Figure 6.3 Remote Programming via Voltage Sources

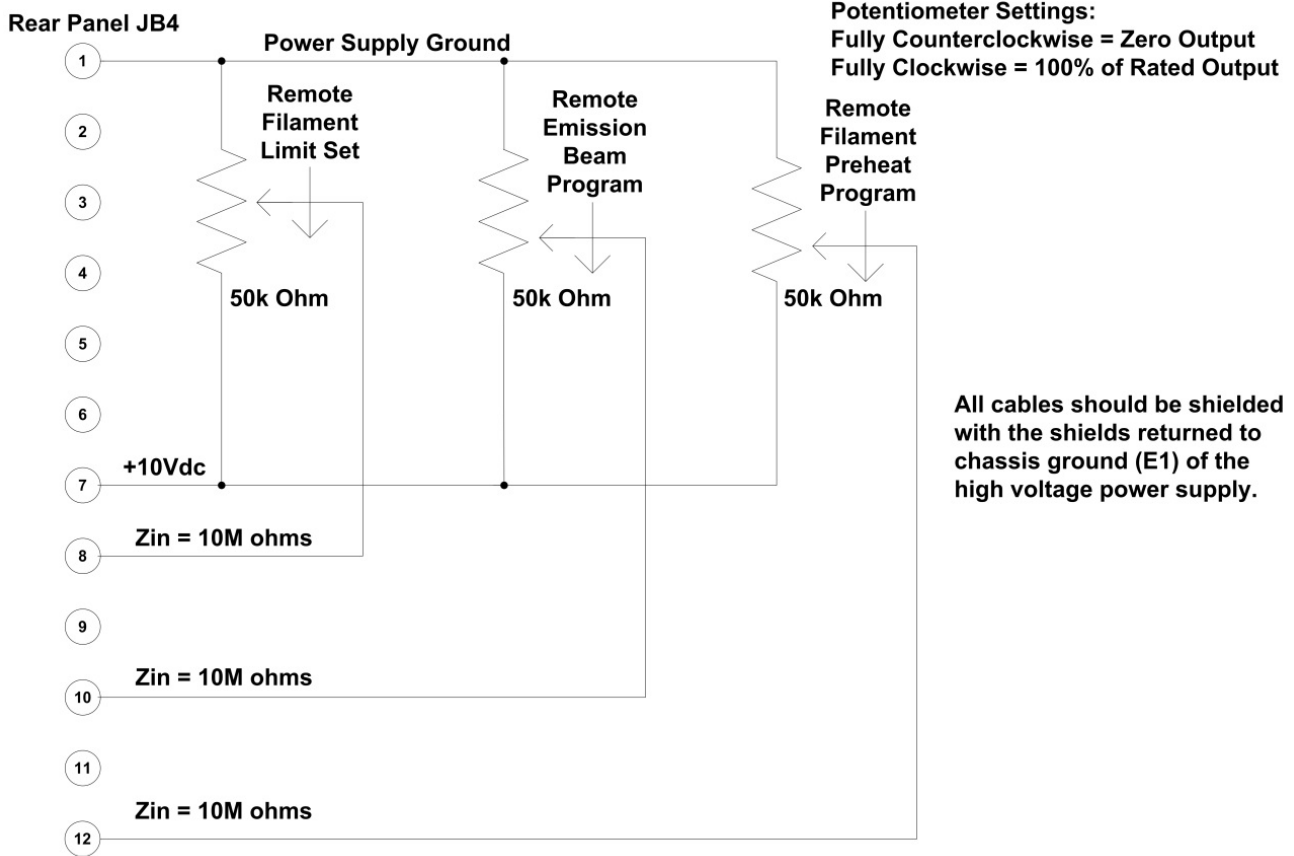

Figure 6.4 Remote Programming via Resistance

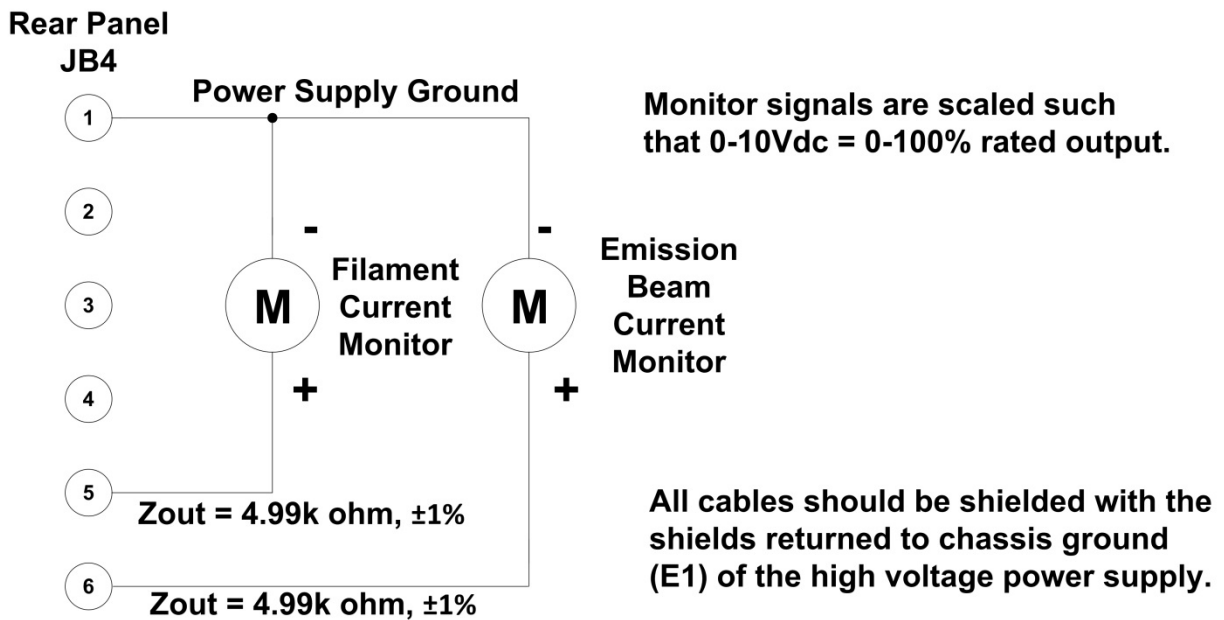
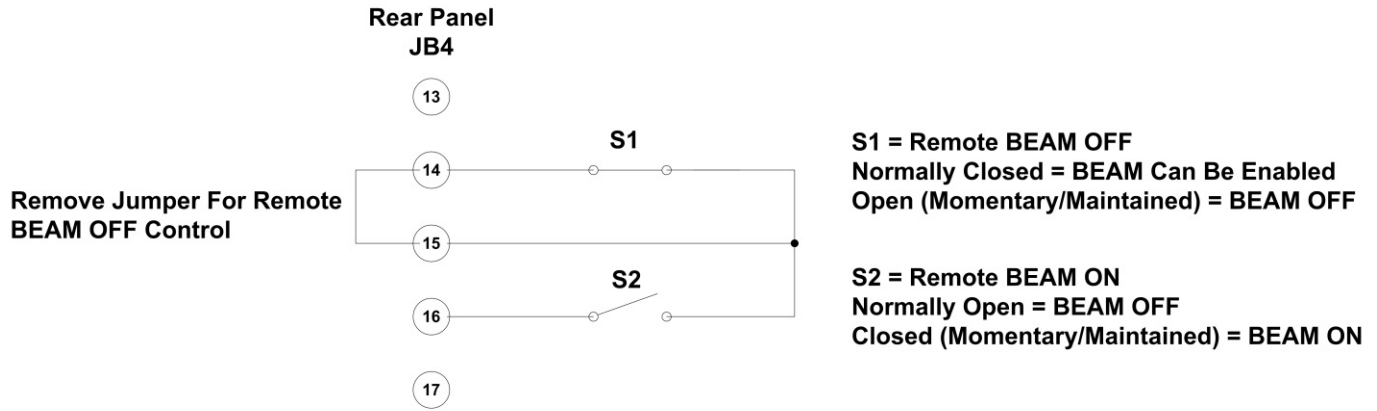

Figure 6.5 Remote Monitor Designations



All cables should be shielded with the shields returned to chassis ground (E1) of the high voltage power supply.

Figure 6.6 Remote BEAM ON / BEAM OFF

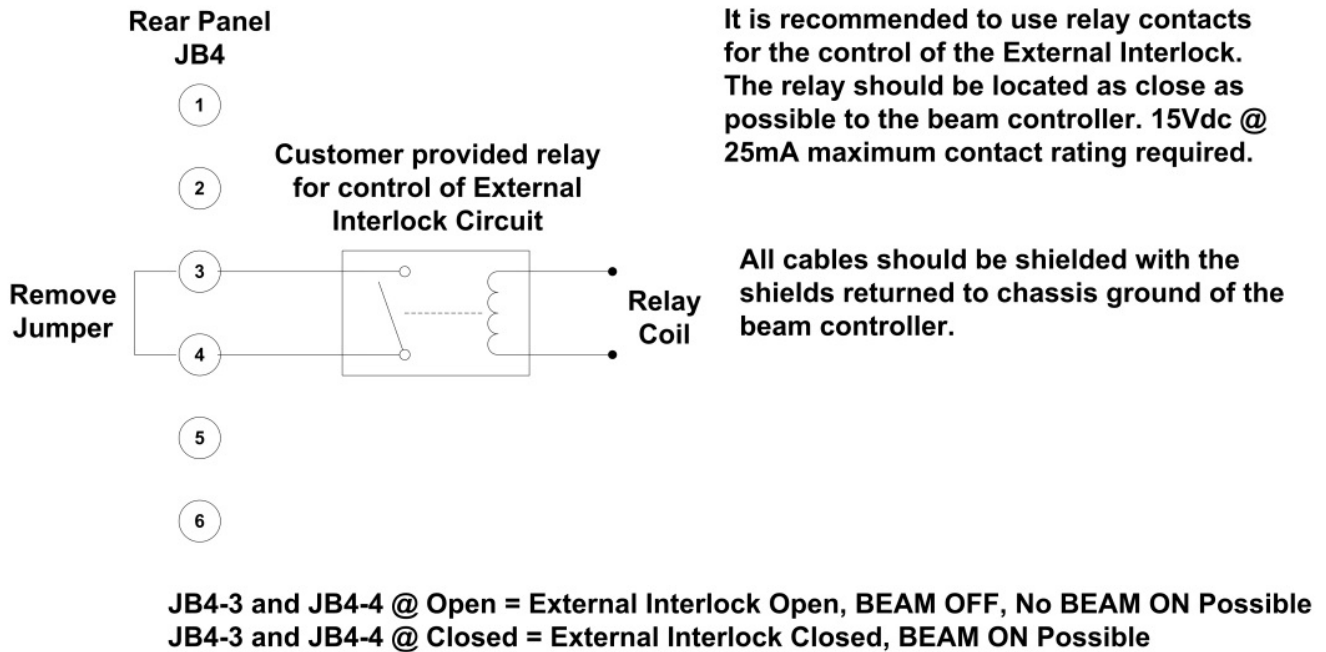

Figure 6.7 External Interlock Interface Circuit

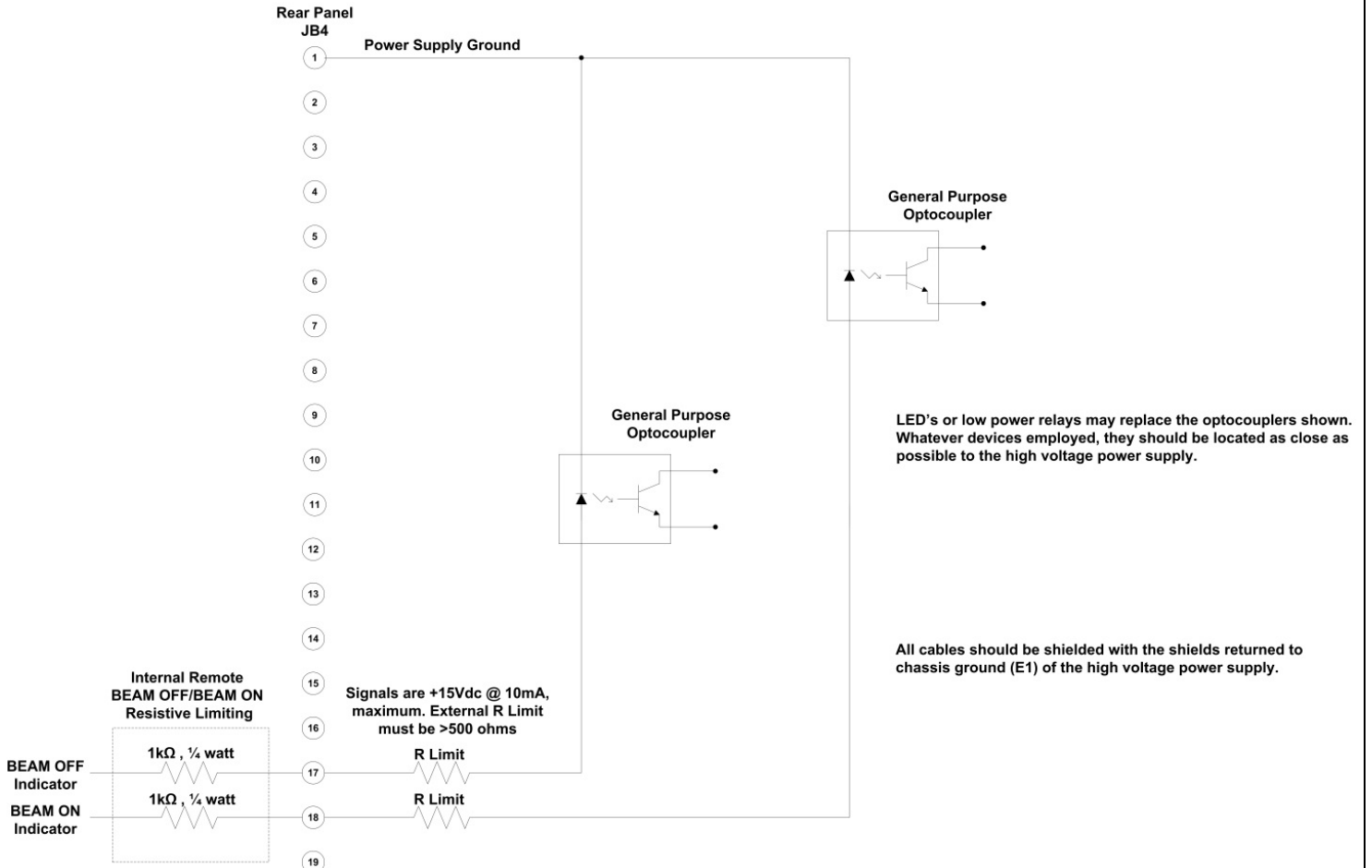

Figure 6.8 Remote BEAM ON /BEAM OFF Indicator

BEAM CONTROLLER INTERFACE – 25 PIN FEMALE D CONNECTOR

PIN	SIGNAL	SIGNAL PARAMETERS
1	Power Supply Common	Signal Ground
2	Spare	
3	External Interlock	+15Vdc at Open, <15mA @ Closed
4	External Interlock Return	Return for Interlock
5	Filament Current Test Point	0 to 10Vdc = 0 to 100% rated output
6	Beam Current Test Point	0 to 10Vdc = 0 to 100% rated output
7	+10Vdc Reference	+10Vdc, 1mA Max
8	Filament Limit Program Input	0 to 10Vdc = 0 to 100% rated output
9	Local Filament Limit Program	Front panel potentiometer wiper
10	Beam Current Program Input	0 to 10Vdc = 0 to 100% rated output
11	Local Beam Current Program	Front panel potentiometer wiper
12	Filament Preheat Program In	0 to 10Vdc = 0 to 100% rated output
13	Local Fil. Preheat Program	Internal potentiometer
14	Beam Off	+15Vdc at Open, <25mA @ Closed
15	Beam On/Off Common	Connect together for FP operation
16	Beam On	Momentarily connect to pin 15 = Beam On
17	Remote Beam Off Indicator	0=Beam On, +15V, 10mA Max=Beam Off
18	Remote Beam On Indicator	0=Beam Off, +15V, 10mA Max=Beam On
19	Spare	
20	Spare	
21	Spare	
22	Remote PS Fault	0 = Fault, +15Vdc @ 0.1mA = No Fault
23	Spare	
24	Power Supply Common	Signal Ground
25	Shield Return	Chassis Ground

 = Denotes jumper connection for simplified front panel operation

Table 6.2 Beam Controller 25 Pin D Remote Interface Connector

Chapter 7

MAINTENANCE

This section describes periodic servicing and performance testing procedures.

WARNING

THIS POWER SUPPLY GENERATES VOLTAGES THAT ARE DANGEROUS AND MAY BE FATAL.

OBSERVE EXTREME CAUTION WHEN WORKING WITH HIGH VOLTAGE.

7.1 Periodic Servicing

Approximately once a year (more often in high dust environments), disconnect the power to the unit and remove the top cover. Use compressed air to blow dust out of the inside of the unit. Avoid touching or handling the high voltage assembly. Be sure that the fan is not obstructed and spins freely. The fan has sealed bearings and does not need lubrication. Be sure to replace the cover before operating for proper cooling.

Turn the chassis over and remove the bottom cover. Use compressed air to blow dust out. NOTE: On 10kV and below, an air insulated high voltage section is used. Avoid touching or handling the high voltage assembly. Be sure to replace the bottom cover before operating the unit.

7.2 Performance Test

WARNING

HIGH VOLTAGE IS DANGEROUS. ONLY QUALIFIED PERSONNEL SHOULD PERFORM THESE TESTS.

High voltage test procedures are described in Bulletin STP-783, available by clicking the following link [Standard Test Procedures for High Voltage Power Supplies](#). Test

equipment, including an oscilloscope, a high impedance voltmeter, and a high voltage divider (such as the Spellman HVD-100) is needed for performance tests. All test components must be rated for applicable operating voltage.

7.3 High Voltage Dividers

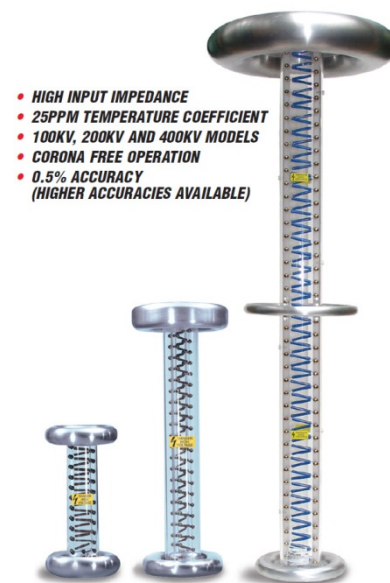

High voltage dividers for precise measurements of output voltage with accuracy up to 0.1% are available from Spellman. The HVD-100 is used for voltages up to 100kV, the HVD-200 measures up to 200kV and the HVD-400 measures up to 400kV. The Spellman HVD divider is designed for use with differential voltmeters or high impedance digital voltmeters. The data sheet for Spellman's series of HVD dividers can be viewed by clicking [here](#).

Chapter 8

REPLACEMENT PARTS

8.1 Replacement Parts

Contact the Spellman Customer Service Department for parts lists for specific models.

Spellman provides parts and subassemblies for its high voltage power supplies but recommends that only qualified personnel perform repairs. High voltage is dangerous; even minor mistakes in repairs can have serious consequences.

When requesting parts, please provide the complete model number and serial number of the power supply in question.

8.2 Correspondence and Ordering Spare Parts

Each Spellman power supply has an identification label on the rear of the chassis that bears its model and serial number.

When requesting engineering or applications information, please state the model and serial number of the power supply. If specific components or circuit sections are involved in the inquiry, it is helpful to indicate the component symbol number(s) shown on the applicable schematic diagram.

When ordering spare parts, please specify the part's description, the part's reference designation or part number, and the model and serial number of the unit. Digital photographs can be very helpful in identify components and/or assemblies.

Chapter 9

FACTORY SERVICE

9.1 Warranty Repairs

During the Warranty period, Spellman will repair all units free of charge. The Warranty is void if the unit is worked on by other than Spellman personnel. See the Warranty in the rear of this manual for more information. Follow the return procedures described in Section 8.2. The customer shall pay for shipping to and from Spellman.

9.2 Factory Service Procedures

Spellman has a well-equipped factory repair department. If a unit is returned to the factory for calibration or repair, a detailed description of the specific problem should be attached.

For all units returned for repair, please obtain an authorization to ship from the Customer Service Department, either by phone or mail prior to shipping. When you call, please state the model and serial numbers, which are on the plate on the rear of the power supply, and the purchase order number for the repair. A Return Material Authorization Code Number (RMA Number) is needed for all returns. This RMA Number should be marked clearly on the outside of the shipping container. Packages received without an RMA Number will be returned to the customer. The Customer shall pay for shipping to and from Spellman.

A preliminary estimate for repairs will be given by phone by Customer Service. A purchase order for this amount is requested upon issuance of the RMA

Number. A more detailed estimate will be made when the power supply is received at the Spellman Repair Center. In the event that repair work is extensive, Spellman will call to seek additional authorization from your company before completing the repairs.

9.3 Ordering Options and Modifications

Many of the options listed in Chapter 5 can be retrofitted into Spellman power supplies by our factory. For prices and arrangements, contact our Sales Department.

9.4 Shipping Instructions

All power supplies returned to Spellman must be sent shipping prepaid. Pack the units carefully and securely in a suitable container, preferably in the original container, if available. The power supply should be surrounded by at least four inches of shock absorbing material. Please return all associated materials, i.e. high voltage output cables, interconnection cables, etc., so that we can examine and test the entire system.

All correspondence and phone calls should be directed to:

Spellman High Voltage Electronics Corp.

475 Wireless Boulevard

Hauppauge, New York 11788

TEL: (631) 630-3000 FAX: (631) 435-1620

E-Mail: sales@spellmanhv.com

www.spellmanhv.com

To obtain information on Spellman's product warranty please visit our website at:

<http://www.spellmanhv.com/en/About/Warranty.aspx>



EVA RS-232 and Ethernet Digital Interface Information



Copyright © 2016, Spellman High Voltage Electronics Corporation. All Rights Reserved. This information contained in this publication is derived in part from proprietary and patent data. This information has been prepared for the express purpose of assisting operating and maintenance personnel in the efficient use of the model described herein, and publication of this information does not convey any right to reproduce it or to use it for any purpose other than in connection with installation, operation, and maintenance of the equipment described.

118167-001 Rev A

USA CHINA EUROPE JAPAN MEXICO

Table Of Contents

1.0 Scope	3
2.0 Functional Description	3
3.0 Getting Started - Interface Wiring and Pin-outs	3
3.1 RS232 Interface.....	3
3.2 Ethernet Interface.....	5
3.3 RS-232 Cabling.....	6
3.4 Ethernet Cabling	6
4.0 Getting Started - Software	7
4.1 RS-232	7
4.2 Ethernet.....	8
5.0 Ethernet Commands	15
5.1 TCP/IP Format	15
5.2 Command Arguments	16
5.3 Command Overview	16
5.4 Response Overview	17
5.5 Command Structure	18
6.0 Serial Commands – RS-232 / USB	37
6.1 Serial Interface Protocol.....	37
6.2 Command Arguments	37
6.3 Checksums	37
6.4 Command Overview	40
6.5 Response Overview	41
6.6 Command Structure	42
6.7 Spellman Test Commands	61
6.8 Serial Command Handling.....	61
7.0 Error Codes	62

WARNING

THIS EQUIPMENT GENERATES DANGEROUS VOLTAGES THAT MAY BE FATAL. PROPER GROUNDING OF ALL HIGH VOLTAGE EQUIPMENT IS ESSENTIAL. SEE EVA OWNERS MANUAL FOR PROPER GROUNDING TECHNIQUE AND SAFETY PRECAUTIONS BEFORE APPLYING AC INPUT POWER TO THE EVA UNIT.

TO PREVENT DAMAGE TO THE HOST COMPUTER THE COMPUTER SHOULD BE GROUNDED TO THE SAME GROUND AS THE UUT.

1.0 SCOPE

This document applies to the communications interfaces on the EVA, assembly 408237.

2.0 FUNCTIONAL DESCRIPTION

The EVA provides 3 different types of digital communications interfaces:

- DB-50F Digital Breakout on JB1
- Ethernet (10/100-Base-T) on JB9

3.0 GETTING STARTED - INTERFACE WIRING AND PIN-OUTS

3.1 RS-232 INTERFACE

The RS-232 interface has the following attributes:

- 115.2K bits per second
- No Parity
- 8 Data Bits
- 1 Stop Bit
- No handshaking
- Included in DB-50F Digital Breakout

The pinout of the DB-50F connector is:

Pin	Signal	Parameters
1	Power Supply Common	Power Supply Ground
2	Reset/HV Inhibit	Toggle to reset latched faults, Ground = Inhibit, Open = HV ON
3	External Interlock	+24Vdc @ open, <25mA @ closed
4	External Interlock Return	Return for External Interlock. Pins 3 and 4 must be connected to HV enable
5	mA Test Point	0-10Vdc = 0-100% rated output, Zout = 1k Ω , 1%
6	kV Test Point	0-10Vdc = 0-100% rated output, Zout = 1k Ω , 1%
7	+10Vdc Reference	+10Vdc @ 1mA
8	mA Program Input	0-10Vdc = 0-100% rated output, Zin =>10M Ω , jump to pin 8 for local control
9	Local mA Program Output	0-10Vdc = 0-100% rated output, front panel potentiometer
10	kV Program Input	0-10Vdc = 0-100% rated output, Zin =>10M Ω , jump to pin 11 for local control
11	Local kV Program Output	0-10Vdc = 0-100% rated output, front panel potentiometer
12	Remote Power On Output	24Vdc @ open, <25mA @ closed
13	Remote Power On Return	Return for Remote Power On
14	Remote HV OFF	+24Vdc @ open, <25mA @ closed, connect to pin 15 for front panel operation
15	Remote HV OFF/ON Common	Remote HV OFF/ON Common
16	Remote HV ON	+24Vdc @ open, <25mA @ closed, momentarily connect to pin 15 for HV enable
17	HV OFF Indicator	+24Vdc @ 25mA = HV OFF
18	HV ON Indicator	+24Vdc @ 25mA = HV ON
19	Power Supply Common	Power Supply Ground
20	+24Vdc Output	+24Vdc @ 100mA, maximum
21	Voltage Mode Status	Open collector, Low = Active, 35V maximum @ 10mA
22	Current Mode Status	Open collector, Low = Active, 35V maximum @ 10mA
23	n/c	
24	Interlock Closed Status	Open collector, Low = Active, 35V maximum @ 10mA
25	n/c	
26	Spare	
27	Spare	
28	Remote Overvoltage Adjust	0-10Vdc = 0-105% rated output
29	n/c	
30	Over Voltage Fault	Open collector, Low = Active, 35V maximum @ 10mA
31	Over Current Fault	Open collector, Low = Active, 35V maximum @ 10mA
32	System Fault	Open collector, Low = Active, 35V maximum @ 10mA
33	RGLT Error Fault	Open collector, Low = Active, 35V maximum @ 10mA
34	ARC	Open collector, Low = Active, 35V maximum @ 10mA
35	Over Temp Fault	Open collector, Low = Active, 35V maximum @ 10mA
36	AC Fault	Open collector, Low = Active, 35V maximum @ 10mA
37	Spare	
38	Spare	
39	Spare	
40	Spare	
41	Spare	
42	Short to pin 43	Connect pin 42 and 43 together in all configurations
43	Short to pin 42	Connect pin 42 and 43 together in all configurations
44	+5Vdc Output	+5Vdc @ 100mA, maximum
45	+15Vdc Output	+15Vdc @ 100mA, maximum
46	-15Vdc Output	-15Vdc @ 10mA, maximum
47	RS-232 Tx	RS-232 Tx
48	RS-232 Rx	RS-232 Rx
49	RS-232 GND	RS-232 GND
50	Power Supply Common	Power Supply Ground

The necessary connections for the RS-232 interface are on pins 47, 48 and 49.

3.2 ETHERNET INTERFACE

The Ethernet interface has the following attributes:

- 10/100-Base-T
- IP address can be set by the system integrator (Default Address: 192.168.1.4)
- Network Mask can be set by the system integrator (Default Mask: 255.255.255.0)
- TCP Port Number can be set by the system integrator (Default Port: 50000)
- RJ-45 connector
- Network attachment via Crossover and Standard Ethernet cables.
- Supported Operating Systems: Windows 98 2ED, Windows 2000 (SP2), Windows NT (SP6), Windows XP Professional

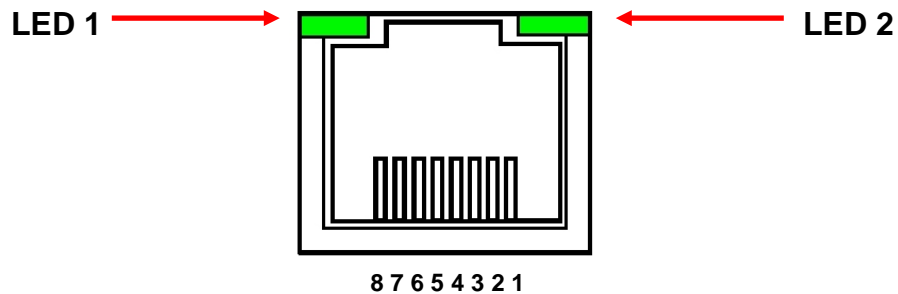

Figure 2 – JB9, Ethernet RJ45 Jack (front view)

PIN	DESCRIPTION
1	TX+
2	TX-
3	RX+
4	-
5	-
6	RX-
7	-
8	-

The Ethernet RJ-45 has two LED indicators, as shown in Figure 2. The left LED, LED1 indicates that the network processor has a valid network link. The right LED, LED2 indicates network activity.

3.3 RS-232 CABLING

A shielded cable is used to connect the EVA serial port through the 50 pin breakout to the serial port on a standard personal computer. Please refer to the following chart.

PC to EVA Board Cable Details	
PC Connector (DB-9 Female)	EVA Connector (DB-50 male)
Pin 2: TX from EVA to PC	Pin 47: TX from EVA to PC
Pin 3: RX to EVA from PC	Pin 48: RX to EVA from PC
Pin 5: Ground	Pin 49: Ground

3.4 ETHERNET CABLING

Shielded Category 5 (CAT5) Ethernet patch cables are used to connect the EVA to the host computer. There are two ways to connect to the EVA board via Ethernet: the first is to directly cable between the host and the EVA board, and the second is through the use of a switch, hub, or network.

A direct connection requires a non-standard cable where the wires are not run straight through. Please refer to the two cable ends shown below in figure 4.

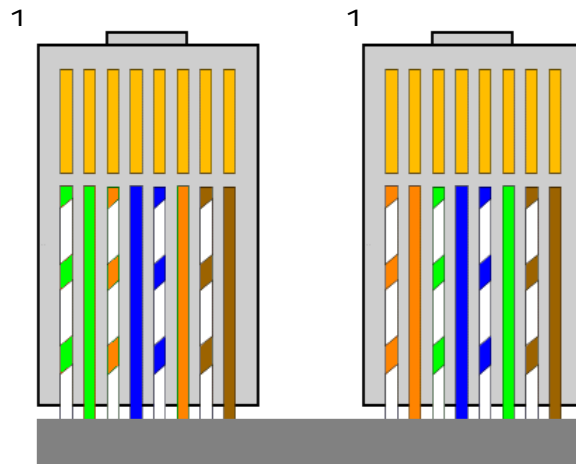

Figure 4 – Crossover Cable for Direct Connection

A standard connection through a hub, switch, or network uses a standard CAT5 patch cable. Please refer to the two cable ends shown below in figure 5

1

1

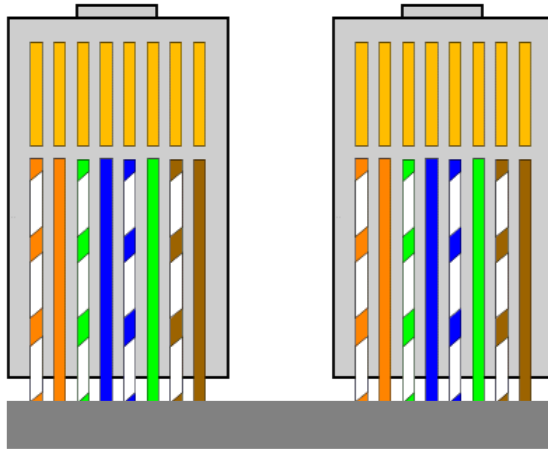

Figure 5 – Standard Straight Through Cable – Standard CAT5 Patch

4.0 GETTING STARTED – SOFTWARE

The following sections detail how to create software to interface to the EVA communications interfaces.

4.1 RS-232

The RS-232 interface makes use of a standard ‘command/response’ communications protocol. See section 6.0 for the syntax of the serial interface protocol.

All software that addresses the RS-232 interface must adhere to the following parameters:

- A Baud rate of 115.2K bps
- No Parity
- 8 Data Bits
- 1 Stop Bit
- No handshaking

4.1.1 Enabling Communications Objects in Visual Basic for RS-232

Communications in Microsoft Visual Basic 6.0 are directed to a control that abstracts the port. In the case of serial we need Microsoft Comm Control 6.0. To enable this in your VB 6 project, go to:

Project -> Components

Then in the list make sure that Microsoft Comm Control 6.0 has a check next to it. The Comm Control Object should then appear in your toolbox. It will have an icon of a telephone and will be named:

MSComm. This can be dragged and dropped into your application. You will then need to set the object's properties.

4.1.2 Configuring Communications in Visual Basic for RS-232

In order to configure the MSComm Object, first you must initialize it in the Object properties:

Settings	115200,n,8,1
Handshaking	0 – comNone

The application can be set to either default to a specific COM Port or the End User can be allowed to choose one for the particular PC. For the "Default" scenario, include the following commands in the Form_Load() routine:

```
MSComm1.CommPort = portNumber  
MSComm1.PortOpen = True
```

For the "Choice" scenario, place the above two commands in a selectable menu item.

4.2 ETHERNET

The EVA contains an embedded diagnostic web server that can be accessed through any standard web browser by browsing to the EVA's IP address. For example:

<http://192.168.1.4>

The Ethernet interface communicates using the following protocols:

- TCP/IP
- HTTP
- TFTP
- FTP

4.2.1 Direct Connection between the EVA and a Computer

A direct Ethernet connection between the EVA and the computer requires an RJ45 crossover cable. The end connectors will look identical to a "normal" RJ45 connector but the colors of some of the wires in the connectors will be "reversed". Hold up the two ends of the RJ45 cable and look at the color of the wires from left to right. They should differ on the two connectors. Please see figure 4 on page 7 for reference.

When direct connecting the EVA to a computer using a crossover cable over Ethernet they are essentially participating in a private network. As such you need to pick two valid IP addresses, one for each device.

The table below illustrates that not all IP addresses are actually valid IP addresses. For example, IP addresses beginning with 127 are not valid.

Class	Address Range
A	1.0.0.0-126.255.255.255
B	128.0.0.0-191.255.255.255
C	192.0.0.0-223.255.255.255

4.2.2.1 Configuring the Computer for Direct Ethernet Connection

As mentioned above both the IP Address and Subnet Mask need to be configured. In our environment computers normally are assigned IP addresses dynamically, using DHCP. We need to change this and assign the IP Address statically to the one we have selected.

Here are the steps on Windows XP. On the desktop right click on “My Network Places” and select properties at the bottom of the menu.

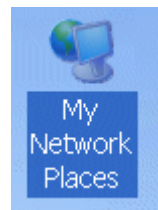

Figure 16 – Right Click on Desktop

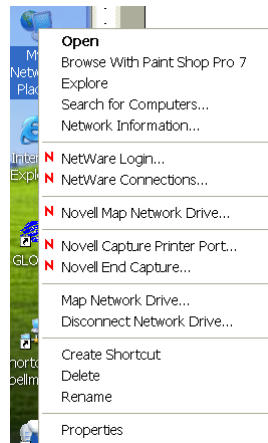

Figure 17 – Select Properties

After selecting properties you are brought up to the screen below (Figure 18). You must **RIGHT CLICK** and select Properties on Local Area Connection, and not double click which will display a window similar to figure 19.

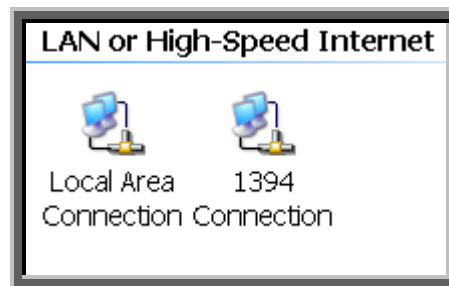

Figure 18 – Here you must Right Click and Select Properties

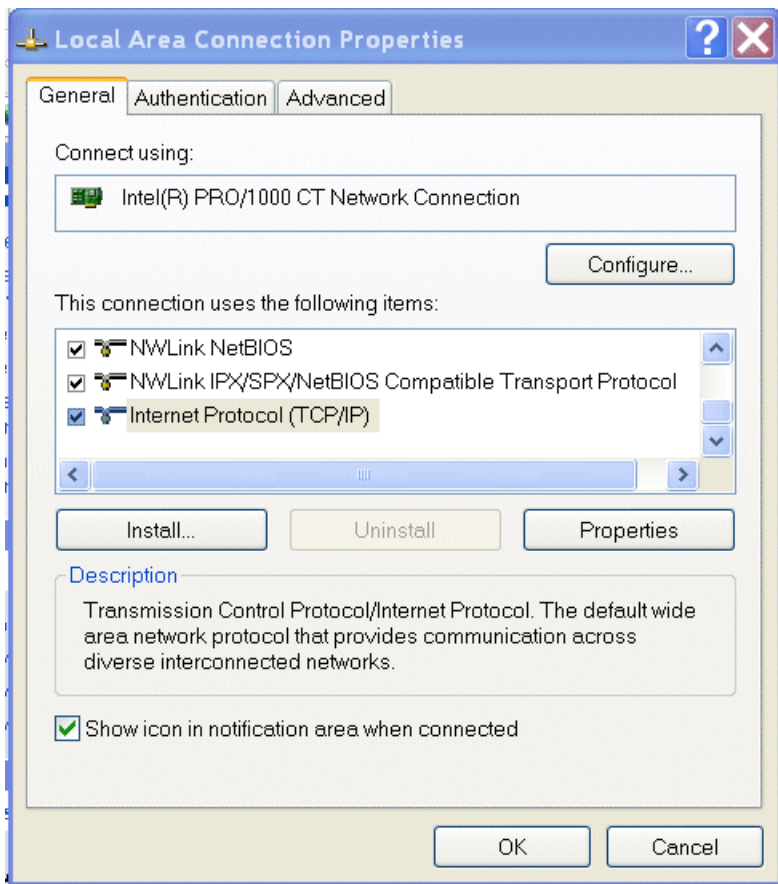

Figure 19 – Local Area Connection Properties

Now you must select “Internet Protocol (TCP/IP)” and click on the Properties button to be brought to figure 20. Lastly you must disable any firewall software you have running. If you are running a proxy server for Internet access, you must also disable the proxy client. Disabling this also requires a reboot.

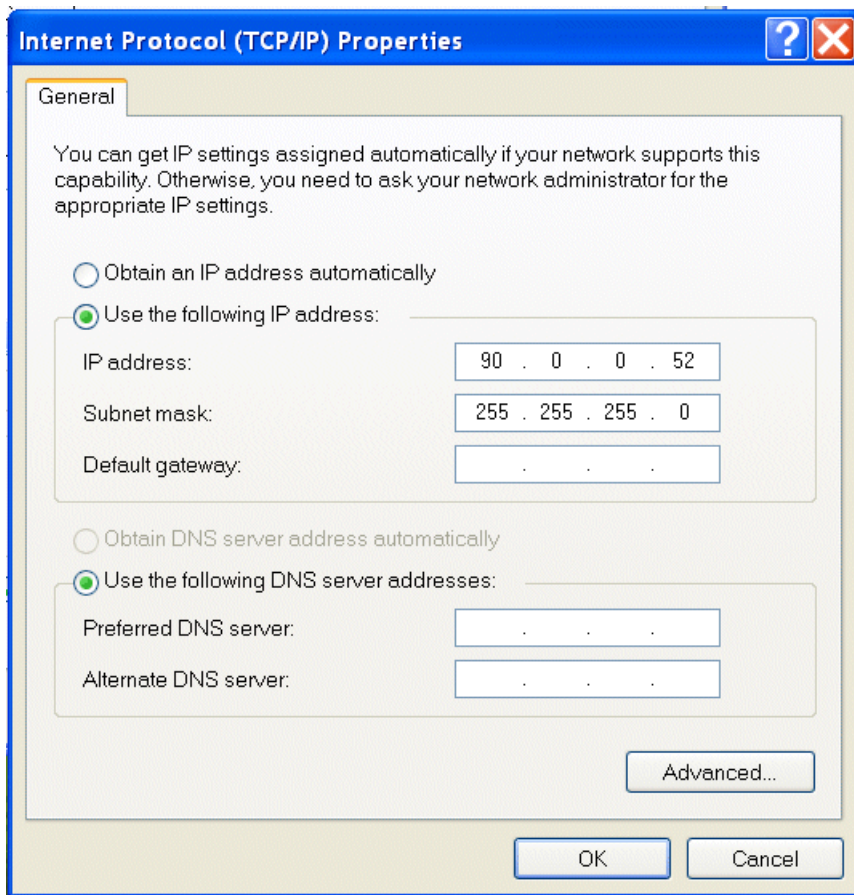

Figure 20 – TCP/IP Properties

4.2.2.2 Testing a Direct Connection

You can use the program “Ping” to test a network connection between the computer and the EVA. “Ping” is a command line tool so we will need to bring up a command prompt. Under Windows NT, 2000 and XP the name of this command is “CMD”. Under Windows 98 the name of this command is “Command”.

To do this, click on Start->Run->Cmd

Then on the command line type

Ping <IP Address>

For example

Ping 192.168.1.4

If the EVA is found at the specified IP address, the Ping command will respond with a report that is similar to:

Pinging 192.168.1.4 with 32 bytes of data:

Reply from 192.168.1.4: bytes=32 time<1ms TTL=64

Reply from 192.168.1.4: bytes=32 time<1ms TTL=64

Reply from 192.168.1.4: bytes=32 time<1ms TTL=64

Reply from 192.168.1.4: bytes=32 time<1ms TTL=64

Ping statistics for 192.168.1.4:

Packets: Sent = 4, Received = 4, Lost = 0 (0% loss),

Approximate round trip times in milli-seconds:

Minimum = 0ms, Maximum = 0ms, Average = 0ms

4.2.3 Configuring the EVA For a Local Area Network (LAN)

If you have chosen to place the EVA onto your local area network you will need:

- A CAT5 network patch cable to physically connect the EVA to the LAN
- A static IP address to assign to the EVA.

Remember that even if the IP address you have selected is in general a valid IP address it needs to be valid for your LAN (local area network). Otherwise the device will not be accessible from an Internet browser or Ping.

4.2.4 Enabling Communications Objects in Visual Basic for Ethernet Communications

For Ethernet communications, we need Microsoft Winsock Control 6.0 and SP5. To enable this in your VB 6 project, go to:

Project -> Components

Once selected in your toolbox you will have an icon of two computers linked together and it will be named: Winsock. This can be dragged and dropped into your application. Then set the object's properties.

4.2.5 Configuring Communications in Visual Basic for Ethernet

In order to configure the Winsock Object, you must make the following initialization in the object's properties:

Protocol 0 – sckTCPProtocol

Then, in the application code, include the following commands:

```
tcpClient.RemoteHost = host
tcpClient.RemotePort = portNumber
tcpClient.Connect
```

For further information regarding the use of the above commands, please refer to your Visual Studio Help File.

4.2.5.1 Data Output Example

MSComm1 is the serial port and TcpClient is the Ethernet port.

```
If (portType = "ethernet") Then
    tcpClient.SendData (str)
Else
    MSComm1.InBufferCount = 0
    On Error GoTo done
    MSComm1.Output = str
done:
    tmrOpenClose.Enabled = True
End If
```

4.2.5.2 Data Input Example

```
If (portType = "ethernet") Then
    Do
        DoEvents
        tcpClient.GetData temp$
        str = str + temp$
        Loop Until InStr(str, Chr(3)) Or Timer - t1 > 1
        On Error Resume Next
    Else
        Do
            DoEvents
            If MSComm1.InBufferCount > 0 Then
                str = str & MSComm1.Input
            End If
            Loop Until InStr(str, Chr(3)) Or Timer - t1 > 1
            If InStr(str, Chr(3)) > 0 Then
                tmrOpenClose.Enabled = False
            End If
        End If
    End If
```

The format of Data Bytes 1 through N are as follows:

<STX><CMD><,>ARG><,><ETX>

Where:

<STX> = 1 ASCII 0x02 Start of Text character
 <CMD> = 2 ASCII characters representing the command ID
 <,> = 1 ASCII 0x2C character
 <ARG> = Command Argument
 <,> = 1 ASCII 0x2C character
 <ETX> = 1 ASCII 0x03 End of Text character

5.2 COMMAND ARGUMENTS

The format of the numbers is a variable length string. To represent the number 42, the string '42', '042', or '0042' can be used. This being the case, commands and responses that carry data are variable in length.

5.3 COMMAND OVERVIEW

TCP/IP Command Overview			
Command Name	<CMD>	<ARG>	RANGE
Program User Configurations	9	See Desc.	See Desc.
Program kV Setpoint	10	1-4 ASCII	0-4095
Program Gun Setpoint	12	3	0-4095
Request kV Setpoint	14	None	-
Request mA Setpoint	15	None	-
Request Misc. Analog Monitor Readbacks	20	None	-
Request Status	22	None	-
Request Software Version	23	None	-
Request Model Number	26	None	-
Request User Configs	27	None	-
Request Unit Scaling	28	None	-
Request FPGA Version	43	None	-
Request kV monitor	60	None	-
Request mA monitor	61	None	-
Request Gun Monitor	62	None	-
Request Gun Faults	68	None	-
Request System Voltages	69	None	-
Reset Faults	74	None	-
Program Local/Remote Mode	99	1 ASCII	0 or 1

5.4 RESPONSE OVERVIEW

The command responses will follow the same network TCP/IP header format as outlined above in section 5.1. This list is comprised of Commands with complex responses only. Commands using a simple response will use the <\$> character (ASCII 0x24) as a “Success” response or a single character error code. These will be seven ASCII characters in length.

Response Name	<CMD>	Response
Request kV Setpoint	14	10 ASCII
Request mA Setpoint	15	10 ASCII
Request Misc. Analog Readbacks	20	21 – 45 ASCII
Request Status	22	37 ASCII
Request Software Version	23	22 ASCII
Request Model Number	26	7 – 21 ASCII
Request User Configs	27	9 – 17 ASCII
Request Unit Scaling	28	9 – 14 ASCII
Request FPGA Version	43	22 ASCII
Request kV monitor	60	7 – 10 ASCII
Request mA monitor	61	7 – 10 ASCII
Request Gun Monitor	62	11-20 ASCII
Request Gun Faults	68	11 ASCII
Request System Voltages	69	45 ASCII

5.5 COMMAND STRUCTURE

5.5.1 Program User Configurations

Description:

The host requests that the firmware set the user configurable items.

Direction:

Host to supply

Syntax:

<STX><09><,><ARG1><,><ARG2><,><ARG3><,><ARG4><,><ETX>

Where:

<ARG1> = kV Rate Ramp

<ARG2> = mA Rate Ramp

<ARG3> = AOL Enable

<ARG4> = Spare

Range:

Valid values for ARG1 and ARG2 are from 0 through 10000 milliseconds.

In 10 milliseconds increments. For ARG3 is 0 (disabled) and 1 (enabled).

For ARG4 use 0.

Response:

If an error is detected, the Power Supply responds with:

<STX>09,!,<ERROR>,<ETX>

Please reference the Error Code section for a list of valid error codes.

If the message is accepted, the Power Supply responds with:

<STX>09,\$,<ETX>

Example:

Set kV and mA to a 10 ms ramp, with AOL disabled.

<STX>09,10,10,0,0,<ETX>

5.5.2 Program kV

Description:

The host requests that the firmware change the kV setpoint.

Direction:

Host to supply

Syntax:

<STX><10><,><ARG><,><ETX>

Where:

<ARG> = 0 - 4095 in ASCII format

Response:

If an error is detected, the Power Supply responds with:

<STX>10,!,<ERROR>,<ETX>

Please reference the Error Code section for a list of valid error codes.

If the message is accepted, the Power Supply responds with:

<STX>10,\$, <ETX>

Example:

Set kV to the full scale voltage.

<STX>10,4095,<ETX>

5.5.3 Program Gun Setpoint

Description:

The host requests that the firmware change the gun setpoint.

Direction:

Host to supply

Syntax:

<STX><12><,><ARG1><,><ARG2><,><ARG3><,><ETX>

Where:

<ARG#> = Beam#X emission current; 0 to 4095 in ASCII format

Scaling: 0.2930409; 4095 corresponds to 1200mA (= 4095 * 0.2930409)

Response:

If an error is detected, the Power Supply responds with:

<STX><12><,><!><,><ERROR><,><ETX>

Please reference the Error Code section for a list of valid error codes.

If the message is accepted, the Power Supply responds with:

<STX><12><,><\$><,><ETX>

5.5.4 Request kV Setpoint

Description:

The host requests that the firmware report the kV setpoint.

Direction:

Host to supply

Syntax:

<STX><14><,><ETX>

Response:

If an error is detected, the Power Supply responds with:

<STX>14,!,<ERROR>,<ETX>

Please reference the Error Code section for a list of valid error codes..

If the message is accepted, the Power Supply responds with:

<STX>14,<ARG>,<ETX>

Where:

<ARG> = 0 - 4095 in ASCII format

Example Response:

KV setpoint is set to full scale.

<STX>14,4095,<ETX>

5.5.5 Request mA Setpoint

Description:

The host requests that the firmware report the current mA setpoint.

Direction:

Host to supply

Syntax:

<STX><15><,><ETX>

Response:

If an error is detected, the Power Supply responds with:

<STX>15,!,<ERROR>,<ETX>

Please reference the Error Code section for a list of valid error codes.

If the message is accepted, the Power Supply responds with:

<STX>15,<ARG>,<ETX>

Where:

<ARG> = 0 - 4095 in ASCII format

Example Response:

MA setpoint is set to full scale.

<STX>15,4095,<ETX>

5.5.6 Request Miscellaneous Analog Monitor Readbacks

Description:

The host requests that the firmware transmit the present values of Miscellaneous Analog Monitor Readbacks.

Direction:

Host to supply

Syntax:

<STX><20><,><ETX>

Response:

If an error is detected, the Power Supply responds with:

<STX>20,!,<ERROR>,<ETX>

Please reference the Error Code section for a list of valid error codes.

If the message is accepted, the Power Supply responds with:

<STX>20,<ARG1>,<ARG2>,<ARG3>,<ARG4>,<ARG5>,<ARG6>,<ARG7>,<ARG8>,<ETX>

Where:

<ARG1> = Remote Over Voltage Protection

<ARG2> = Spare

<ARG3> = Spare

<ARG4> = Spare

<ARG5> = Control Board Temperature

<ARG6> = Spare

<ARG7> = Spare

<ARG8> = Spare

Range:

Valid values are 0 - 4095 in ASCII format.

Example Response:

<STX>20,2048,0,0,0,1023,0,0,0,<ETX>

5.5.8 Request DSP Software Part Number/Version

Description:

The host requests that the firmware sends the firmware send the DSP Software part and build number.

Direction:

Host to supply

Syntax:

<STX><23><,><ETX>

Response:

If an error is detected, the Power Supply responds with:

<STX>23,!,<ERROR>,<ETX>

Please reference the Error Code section for a list of valid error codes.

If the message is accepted, the Power Supply responds with:

<STX>23,<ARG1>,<ARG2>,<ETX>

Where:

<ARG1> = Consists of eleven ASCII characters representing the current firmware part number/version. The format is SWM9999-999.

<ARG2> = Consists of four ASCII characters representing the current build number. The format is 3261.

Example Response:

<STX>23, SWM9999-999,3261,<ETX>

5.5.9 Request Model Number

Description:

The host requests that the firmware sends the unit model number.

Direction:

Host to supply

Syntax:

<STX><26><,><ETX>

Response:

If an error is detected, the Power Supply responds with:

<STX>26,!,<ERROR>,<ETX>

Please reference the Error Code section for a list of valid error codes.

If the message is accepted, the Power Supply responds with:

<STX>26,<ARG>,<ETX>

Where:

<ARG> = Consists up to fifteen ASCII characters representing the current model number.

Example Response:

<STX>26,ST100P100X4249,<ETX>

5.5.10 Request User Configurations

Description:

The host requests that the firmware send the user configurable items.

Direction:

Host to supply

Syntax:

<STX><27><,><ETX>

Response:

If an error is detected, the Power Supply responds with:

<STX>27,!,<ERROR>,<ETX>

Please reference the Error Code section for a list of valid error codes.

If the message is accepted, the Power Supply responds with:

<STX>27,<ARG1>,<ARG2>,<ARG3>,<ARG4>,<ETX>

Where:

<ARG1> = kV Rate Ramp

<ARG2> = mA Rate Ramp

<ARG3> = AOL Enabled

<ARG4> = Spare

Range:

Valid values for ARG1 and ARG2 are from 0 through 10000 milliseconds.

For ARG3 is 0 (disabled) and 1 (enabled).

Example Response:

kV and mA set to a 10 millisecond ramp, with AOL enabled.

<STX>27,10,10,1,0,<ETX>

5.5.11 Request Unit Scaling

Description:

The host requests that the firmware send the full scale range values.

Direction:

Host to supply

Syntax:

<STX><28><,><ETX>

Response:

If an error is detected, the Power Supply responds with:

<STX>28,!,<ERROR>,<ETX>

Please reference the Error Code section for a list of valid error codes.

If the message is accepted, the Power Supply responds with:

<STX>28,<ARG1>,<ARG2>,<ETX>

Where:

<ARG1> = Full Scale kV Value

<ARG2> = Full Scale mA Value

Example Response:

For a 100kV/1000mA power supply

<STX>28,100,1000,<ETX>

5.5.12 Request FPGA Software Part Number/Version

Description:

The host requests that the firmware send the FPGA Software part and build number.

Direction:

Host to supply

Syntax:

<STX><43><,><ETX>

Response:

If an error is detected, the Power Supply responds with:

<STX>43,!,<ERROR>,<ETX>

Please reference the Error Code section for a list of valid error codes.

If the message is accepted, the Power Supply responds with:

<STX>43,<ARG1>,<ARG2>,<ETX>

Where:

<ARG1> = Consists of eleven ASCII characters representing the current firmware part number/version. The format is SWM9999-999.

<ARG2> = Consists of four ASCII characters representing the current build number. The format is 3261.

Example Response:

<STX>43,SWM9999-999,3261,<ETX>

5.5.13 Request kV Monitor

Description:

The host requests that the firmware report kV monitor.

Direction:

Host to supply

Syntax:

<STX><60><,><ETX>

Response:

If an error is detected, the Power Supply responds with:

<STX>60,!,<ERROR>,<ETX>

Please reference the Error Code section for a list of valid error codes.

If the message is accepted, the Power Supply responds with:

<STX>60,<ARG>,<ETX>

Where:

<ARG> = 0 - 4095 in ASCII format

Example Response:

KV monitor is set to full scale.

<STX>60,4095,<ETX>

5.5.14 Request mA Monitor

Description:

The host requests that the firmware report mA monitor.

Direction:

Host to supply

Syntax:

<STX><61><,><ETX>

Response:

If an error is detected, the Power Supply responds with:

<STX>61,!,<ERROR>,<ETX>

Please reference the Error Code section for a list of valid error codes.

If the message is accepted, the Power Supply responds with:

<STX>61,<ARG>,<ETX>

Where:

<ARG> = 0 - 4095 in ASCII format

Example Response:

mA monitor is set to full scale.

<STX>61,4095,<ETX>

5.5.15 Request Gun Monitor

Description:

The host requests that the firmware report gun monitor.

Direction:

Host to supply

Syntax:

<STX><62><,><ETX>

Response:

If an error is detected, the Power Supply responds with:

<STX><62><,><!><,><ERROR><,><ETX>

Please reference the Error Code section for a list of valid error codes.

If the message is accepted, the Power Supply responds with:

<STX><62><,><ARG1><,><ARG2><,><ARG3><,><ETX>

Where:

<ARG#> = Beam#X emission current; 0 to 4095 in ASCII format

Scaling: 0.2930409; 4095 corresponds to 1200mA (= 4095 * 0.2930409)

5.5.16 Request Gun Faults

Description:

The host requests that the firmware report Gun Faults.

Direction:

Host to supply

Syntax:

<STX><68><,><ETX>

Response:

If an error is detected, the Power Supply responds with:

<STX><68><,><!><,><ERROR><,><ETX>

Please reference the Error Code section for a list of valid error codes.

If the message is accepted, the Power Supply responds with:

<STX><68><,><ARG1><,><ARG2><,><ARG3><,><ETX>

Where:

<ARGx> = Beam#X fault; 0 or 1 in ASCII format

Range:

0 = Off/No Fault

1 = On/Fault

5.5.17 Request System Voltages

Description:

The host requests that the firmware report System Voltages.

Direction:

Host to supply

Syntax:

<STX><69><,><ETX>

Response:

If an error is detected, the Power Supply responds with:

<STX>69,!,<ERROR>,<ETX>

Please reference the Error Code section for a list of valid error codes.

If the message is accepted, the Power Supply responds with:

<STX>69,<ARG1>,<ARG2>,<ARG3>,<ARG4>,<ARG5>,<ARG6>,<ARG7>,<ETX>

Where:

<ARG1> = AC Line Voltage in ASCII 0-4095 format, 0 to 375V

<ARG2> = 24V rail in ASCII 0-4095 format, 0 to 33V

<ARG3> = 15V rail in ASCII 0-4095 format, 0 to 21V

<ARG4> = 5V rail in ASCII 0-4095 format, 0 to 6V

<ARG5> = 3.3V rail in ASCII 0-4095 format, 0 to 5 V

<ARG6> = -15V in ASCII 0-4095 format, 0 to -33V

<ARG7> = Spare rail in ASCII 0-4095 format, 0 to 45V

Example Response:

<STX>69,1302,3047,3008,3426,2711,1857,2243,<ETX>

5.5.18 Reset Faults

Description:

The host requests the firmware to clear latched faults.

Direction:

Host to supply

Syntax:

<STX><74><,><ETX>

Response:

If an error is detected, the Power Supply responds with:

<STX>74,!,<ERROR>,<ETX>

Please reference the Error Code section for a list of valid error codes.

If the message is accepted, the Power Supply responds with:

<STX>74,\$,<ETX>

5.5.19 Program Local/Remote Mode

Description:

The host requests the firmware to switch between Local and Remote Mode.

Direction:

Host to supply

Syntax:

<STX><99><,><ARG><,><ETX>

Where:

<ARG> 1 = Remote, 0 = Local in ASCII format

Response:

If an error is detected, the Power Supply responds with:

<STX>99,!,<ERROR>,<ETX>

Please reference the Error Code section for a list of valid error codes.

If the message is accepted, the Power Supply responds with:

<STX>99,\$,<ETX>

6.0 SERIAL COMMANDS – RS-232

6.1 SERIAL INTERFACE PROTOCOL

Serial communications will use the following protocol:

<STX><CMD><,>ARG><,><CSUM><ETX>

Where:

<STX> = 1 ASCII 0x02 Start of Text character
<CMD> = 2 ASCII characters representing the command ID
<,> = 1 ASCII 0x2C character
<ARG> = Command Argument
<,> = 1 ASCII 0x2C character
<CSUM> = Checksum (see section 6.3 for details)
<ETX> = 1 ASCII 0x03 End of Text character

6.2 COMMAND ARGUMENTS

The format of the numbers is a variable length string. To represent the number 42, the string '42', '042', or '0042' can be used. This being the case, commands and responses that carry data are variable in length.

6.3 CHECKSUMS

The checksum is computed as follows:

- Add the <CMD>, <,>, and <ARG> bytes into a 16 bit (or larger) word. The bytes are added as unsigned integers.
- Take the 2's compliment (negate it).
- Truncate the result down to the eight least significant bits.
- Clear the most significant bit (bit 7) of the resultant byte, (bitwise AND with 0x7F).
- Set the next most significant bit (bit 6) of the resultant byte (bitwise OR with 0x40).

Using this method, the checksum is always a number between 0x40 and 0x7F. The checksum can never be confused with the <STX> or <ETX> control characters, since these have non-overlapping ASCII values.

If the DSP detects a checksum error, the received message is ignored – no acknowledge or data is sent back to the host. A timeout will act as an implied NACK.

The following is sample code, written in Visual Basic, for the generation of checksums:

```
Public Function ProcessOutputString(outputString As String) As String

    Dim i As Integer
    Dim CSb1 As Integer
    Dim CSb2 As Integer
```

```

Dim CSb3 As Integer
Dim CSb$
Dim X

X = 0
For i = 1 To (Len(outputString)) 'Starting with the CMD character
X = X + Asc(Mid(outputString, i, 1)) 'adds ascii values together
Next i

CSb1 = 256 - X
CSb2 = 127 And (CSb1) 'Twos Complement
CSb3 = 64 Or (CSb2) 'OR 0x40
CSb$ = Chr(Val("&H" & (Hex(CSb3))))
ProcessOutputString = Chr(2) & outputString & CSb$ & Chr(3)

End Function

```

Here is an example of an actual Checksum calculation for command 10 (Program kV setpoint)

The original message with a placeholder for the checksum is
 <STX>10,4095,<CSUM><ETX>

- First, you add up all the characters starting with the '1' in the command number, to the comma before the checksum with their ASCII values (in hexadecimal):

$$0x31 + 0x30 + 0x2C + 0x34 + 0x30 + 0x39 + 0x35 + 0x2C = 0x18B$$

- Next, you then take the two's complement of that number by negating it, by subtracting it from 0x100 (decimal 256), and only retain the lowest 7 bits by bitwise ANDing the results with 0x7F. :

NOTE: This combines the steps of getting the twos complement, truncating the result to 8 bits and clearing the 8th bit.

$$(0x100 - 0x18B) \& 0x7F = 0x75$$

- Finally, bitwise OR the result with 0x40:

$$0x75 | 0x40 = 0x75$$

The checksum byte is 0x75 (Decimal 117, ASCII: u)

Here is another example, this time for command 22 (Request Status) which has no arguments.

The original message with a placeholder for checksum is:

<STX>22,<CSUM><ETX>

- First, you add up all the characters starting with the '2' in the command number to the comma before the checksum with their ASCII values (in hexadecimal):

$0x32 + 0x32 + 0x2C = 0x90$

- Next, you then take the two's complement of that number by negating it, by subtracting it from 0x100 (decimal 256), and only retain the lowest 7 bits by bitwise ANDing the results with 0x7F:

NOTE: This combines the steps of getting the twos complement, truncating the result to 8 bits and clearing the 8th bit.

$(0x100 - 0x90) \& 0x7F = 0x70$

- Finally, bitwise OR the result with 0x40:

$0x70 | 0x40 = 0x70$

The checksum byte is 0x70 (Decimal 112, ASCII: p)

6.4 COMMAND OVERVIEW

Serial Command Overview			
Command Name	<CMD>	<ARG>	RANGE
Program User Configurations	9	See Desc.	See Desc.
Program kV Setpoint	10	1-4 ASCII	0-4095
Program Gun Setpoint	12	3	0-4095
Request kV Setpoint	14	None	-
Request mA Setpoint	15	None	-
Request Misc. Analog Monitor Readbacks	20	None	-
Request Status	22	None	-
Request Software Version	23	None	-
Request Model Number	26	None	-
Request User Configs	27	None	-
Request Unit Scaling	28	None	-
Request FPGA Version	43	None	-
Request kV monitor	60	None	-
Request mA monitor	61	None	-
Request Gun Monitor	62	None	-
Request Gun Faults	68	None	-
Request System Voltages	69	None	-
Reset Faults	74	None	-
Program Local/Remote Mode	99	1 ASCII	0 or 1

6.5 RESPONSE OVERVIEW

The command responses will follow the same format as outlined above in section 6.1. This list is comprised of Commands with complex responses only. Commands using a simple response will use the <\$> character (ASCII 0x24) as a “Success” response or a single character error code. These responses will be eight ASCII characters in length.

Response Name	<CMD>	Response
Request kV Setpoint	14	11 ASCII
Request mA Setpoint	15	11 ASCII
Request Misc. Analog Readbacks	20	22 – 46 ASCII
Request Status	22	38 ASCII
Request Software Version	23	23 ASCII
Request Model Number	26	8 – 22 ASCII
Request User Configs	27	10 – 18 ASCII
Request Unit Scaling	28	10 – 15 ASCII
Request FPGA Version	43	23 ASCII
Request kV monitor	60	8 – 11 ASCII
Request mA monitor	61	8 – 11 ASCII
Request Gun Monitor	62	11-20 ASCII
Request Gun Faults	68	11 ASCII
Request System Voltages	69	46 ASCII

6.6 COMMAND STRUCTURE

6.6.1 Program User Configurations

Description:

The host requests that the firmware set the user configurable items.

Direction:

Host to supply

Syntax:

<STX><09><,><ARG1><,><ARG2><,><ARG3><,><ARG4><,><CSUM><ETX>

Where:

<ARG1> = kV Rate Ramp
<ARG2> = mA Rate Ramp
<ARG3> = AOL Enable
<ARG4> = Spare

Range:

Valid values for ARG1 and ARG2 are from 0 through 10000 milliseconds. In 10 milliseconds increments. For ARG3 is 0 (disabled) and 1 (enabled). For ARG4 use 0.

Response:

If an error is detected, the Power Supply responds with:

<STX>09,!,<ERROR>,<CSUM><ETX>

Please reference the Error Code section for a list of valid error codes.

If the message is accepted, the Power Supply responds with:

<STX>09,\$,<CSUM><ETX>

Example:

Set kV and mA to a 10 ms ramp, with AOL disabled.

<STX>09,10,10,0,0,<CSUM><ETX>

6.6.2 Program kV

Description:

The host requests that the firmware change the kV setpoint.

Direction:

Host to supply

Syntax:

<STX><10><,><ARG><,><CSUM><ETX>

Where:

<ARG> = 0 - 4095 in ASCII format

Response:

If an error is detected, the Power Supply responds with:

<STX>10,!,<ERROR>,<CSUM><ETX>

Please reference the Error Code section for a list of valid error codes.

If the message is accepted, the Power Supply responds with:

<STX>10,\$,<CSUM><ETX>

Example:

Set kV to the full scale voltage.

<STX>10,4095,<CSUM><ETX>

6.6.3 Program Gun Setpoint

Description:

The host requests that the firmware change the gun setpoint.

Direction:

Host to supply

Syntax:

<STX><12><,><ARG1><,><ARG2><,><ARG3><,><CSUM><ETX>

Where:

<ARG#> = Beam#X emission current; 0 to 4095 in ASCII format

Scaling: 0.2930409; 4095 corresponds to 1200mA (= 4095 * 0.2930409)

Response:

If an error is detected, the Power Supply responds with:

<STX><12><,><!><,><ERROR><,><CSUM><ETX>

Please reference the Error Code section for a list of valid error codes.

If the message is accepted, the Power Supply responds with:

<STX><12><,><\$><,><CSUM><ETX>

6.6.4 Request kV Setpoint

Description:

The host requests that the firmware report the kV setpoint.

Direction:

Host to supply

Syntax:

<STX><14><,><CSUM><ETX>

Response:

If an error is detected, the Power Supply responds with:

<STX>14,!,<ERROR>,<CSUM><ETX>

Please reference the Error Code section for a list of valid error codes..

If the message is accepted, the Power Supply responds with:

<STX>14,<ARG>,<CSUM><ETX>

Where:

<ARG> = 0 - 4095 in ASCII format

Example Response:

KV setpoint is set to full scale.

<STX>14,4095,<CSUM><ETX>

6.6.5 Request mA Setpoint

Description:

The host requests that the firmware report the current mA setpoint.

Direction:

Host to supply

Syntax:

<STX><15><,><CSUM><ETX>

Response:

If an error is detected, the Power Supply responds with:

<STX>15,!,<ERROR>,<CSUM><ETX>

Please reference the Error Code section for a list of valid error codes.

If the message is accepted, the Power Supply responds with:

<STX>15,<ARG>,<CSUM><ETX>

Where:

<ARG> = 0 - 4095 in ASCII format

Example Response:

MA setpoint is set to full scale.

<STX>15,4095,<CSUM><ETX>

6.6.6 Request Miscellaneous Analog Monitor Readbacks

Description:

The host requests that the firmware transmit the present values of Miscellaneous Analog Monitor Readbacks.

Direction:

Host to supply

Syntax:

<STX><20><,><CSUM><ETX>

Response:

If an error is detected, the Power Supply responds with:

<STX>20,!,<ERROR>,<CSUM><ETX>

Please reference the Error Code section for a list of valid error codes.

If the message is accepted, the Power Supply responds with:

<STX>20,<ARG1>,<ARG2>,<ARG3>,<ARG4>,<ARG5>,<ARG6>,<ARG7>,<ARG8>,<CSUM><ETX>

Where:

<ARG1> = Remote Over Voltage Protection

<ARG2> = Spare

<ARG3> = Spare

<ARG4> = Spare

<ARG5> = Control Board Temperature

<ARG6> = Spare

<ARG7> = Spare

<ARG8> = Spare

Range:

Valid values are 0 - 4095 in ASCII format.

Example Response:

<STX>20,2048,0,0,0,1023,0,0,0,<CSUM><ETX>

6.6.7 Request Status/Faults

Description:

The host requests that the firmware sends the power supply statuses and faults.

Direction:

Host to supply

Syntax:

<STX><22><,><CSUM><ETX>

Response:

If an error is detected, the Power Supply responds with:

<STX>22,!,<ERROR>,<CSUM><ETX>

Please reference the Error Code section for a list of valid error codes.

If the message is accepted, the Power Supply responds with:

<STX>22,<ARG1>,<ARG2>,<ARG3>,<ARG4>,<ARG5>,<ARG6>,
<ARG7>,<ARG8>,<ARG9>,<ARG10>,<ARG11>,<ARG12>,
<ARG13>,<ARG14>,<ARG15>,<ARG16>,<ARG17>,<CSUM>
<ETX>

Where:

<ARG1> = Power On	<ARG10> = Regulation Error
<ARG2> = HV On	<ARG11> = Current Control Mode
<ARG3> = Arc	<ARG12> = Over Temperature
<ARG4> = Interlock Closed	<ARG13> = Spare
<ARG5> = Over Current	<ARG14> = AC Fault
<ARG6> = Spare	<ARG15> = Local/Remote Mode
<ARG7> = Over Voltage	<ARG16> = LVPS Fault
<ARG8> = Voltage Control Mode	<ARG17> = HV Inhibit
<ARG9> = System Fault	

Range:

Valid values are 0 or 1 in ASCII format.

0 = Off/No Fault

1 = On/Fault

Example Response:

Power's On with an Over Current Fault.

<STX>22,1,0,0,0,1,0,0,0,1,0,0,0,0,0,0,0,0,0,<CSUM><ETX>

6.6.8 Request DSP Software Part Number/Version

Description:

The host requests that the firmware sends the firmware send the DSP Software part and build number.

Direction:

Host to supply

Syntax:

<STX><23><,><CSUM><ETX>

Response:

If an error is detected, the Power Supply responds with:

<STX>23,!,<ERROR>,<CSUM><ETX>

Please reference the Error Code section for a list of valid error codes.

If the message is accepted, the Power Supply responds with:

<STX>23,<ARG1>,<ARG2>,<CSUM><ETX>

Where:

<ARG1> = Consists of eleven ASCII characters representing the current firmware part number/version. The format is SWM9999-999.

<ARG2> = Consists of four ASCII characters representing the current build number. The format is 3261.

Example Response:

<STX>23, SWM9999-999,3261,<CSUM><ETX>

6.6.9 Request Model Number

Description:

The host requests that the firmware sends the unit model number.

Direction:

Host to supply

Syntax:

<STX><26><,><CSUM><ETX>

Response:

If an error is detected, the Power Supply responds with:

<STX>26,!,<ERROR>,<CSUM><ETX>

Please reference the Error Code section for a list of valid error codes.

If the message is accepted, the Power Supply responds with:

<STX>26,<ARG>,<CSUM><ETX>

Where:

<ARG> = Consists up to fifteen ASCII characters representing the current model number.

Example Response:

<STX>26,ST100P100X4249,<CSUM><ETX>

6.6.10 Request User Configurations

Description:

The host requests that the firmware send the user configurable items.

Direction:

Host to supply

Syntax:

<STX><27><,><CSUM><ETX>

Response:

If an error is detected, the Power Supply responds with:

<STX>27,!,<ERROR>,<ETX>

Please reference the Error Code section for a list of valid error codes.

If the message is accepted, the Power Supply responds with:

<STX>27,<ARG1>,<ARG2>,<ARG3>,<ARG4>,<CSUM><ETX>

Where:

<ARG1> = kV Rate Ramp

<ARG2> = mA Rate Ramp

<ARG3> = AOL Enabled

<ARG4> = Spare

Range:

Valid values for ARG1 and ARG2 are from 0 through 10000 milliseconds.

For ARG3 is 0 (disabled) and 1 (enabled).

Example Response:

kV and mA to a 10 millisecond ramp, with AOL enabled.

<STX>27,10,10,1,0,<CSUM><ETX>

6.6.11 Request Unit Scaling

Description:

The host requests that the firmware send the full scale range values.

Direction:

Host to supply

Syntax:

<STX><28><,><CSUM><ETX>

Response:

If an error is detected, the Power Supply responds with:

<STX>28,!,<ERROR>,<ETX>

Please reference the Error Code section for a list of valid error codes.

If the message is accepted, the Power Supply responds with:

<STX>28,<ARG1>,<ARG2>,<CSUM><ETX>

Where:

<ARG1> = Full Scale kV Value

<ARG2> = Full Scale mA Value

Example Response:

For a 100kV/1000mA power supply

<STX>28,100,1000,<CSUM><ETX>

6.6.12 Request FPGA Software Part Number/Version

Description:

The host requests that the firmware send the FPGA Software part and build number.

Direction:

Host to supply

Syntax:

<STX><43><,><CSUM><ETX>

Response:

If an error is detected, the Power Supply responds with:

<STX>43,!,<ERROR>,<CSUM><ETX>

Please reference the Error Code section for a list of valid error codes.

If the message is accepted, the Power Supply responds with:

<STX>43,<ARG1>,<ARG2>,<CSUM><ETX>

Where:

<ARG1> = Consists of eleven ASCII characters representing the current firmware part number/version. The format is SWM9999-999.

<ARG2> = Consists of four ASCII characters representing the current build number. The format is 3261.

Example Response:

<STX>43,SWM9999-999,3261,<CSUM><ETX>

6.6.13 Request kV Monitor

Description:

The host requests that the firmware report kV monitor.

Direction:

Host to supply

Syntax:

<STX><60><,><CSUM><ETX>

Response:

If an error is detected, the Power Supply responds with:

<STX>60,!,<ERROR>,<CSUM><ETX>

Please reference the Error Code section for a list of valid error codes.

If the message is accepted, the Power Supply responds with:

<STX>60,<ARG>,<CSUM><ETX>

Where:

<ARG> = 0 - 4095 in ASCII format

Example Response:

KV monitor is set to full scale.

<STX>60,4095,<CSUM><ETX>

6.6.14 Request mA Monitor

Description:

The host requests that the firmware report mA monitor.

Direction:

Host to supply

Syntax:

<STX><61><,><CSUM><ETX>

Response:

If an error is detected, the Power Supply responds with:

<STX>61,!,<ERROR>,<CSUM><ETX>

Please reference the Error Code section for a list of valid error codes.

If the message is accepted, the Power Supply responds with:

<STX>61,<ARG>,<CSUM><ETX>

Where:

<ARG> = 0 - 4095 in ASCII format

Example Response:

mA monitor is set to full scale.

<STX>61,4095,<CSUM><ETX>

6.6.15 Request Gun Monitor

Description:

The host requests that the firmware report gun monitor.

Direction:

Host to supply

Syntax:

<STX><62><,><CSUM><ETX>

Response:

If an error is detected, the Power Supply responds with:

<STX><62><,><!><,><ERROR><,><CSUM><ETX>

Please reference the Error Code section for a list of valid error codes.

If the message is accepted, the Power Supply responds with:

<STX><62><,><ARG1><,><ARG2><,><ARG3><,><CSUM><ETX>

Where:

<ARG#> = Beam#X emission current; 0 to 4095 in ASCII format

Scaling: 0.2930409; 4095 corresponds to 1200mA (= 4095 * 0.2930409)

6.6.16 Request Gun Faults

Description:

The host requests that the firmware report Gun Faults.

Direction:

Host to supply

Syntax:

<STX><68><,><CSUM><ETX>

Response:

If an error is detected, the Power Supply responds with:

<STX><68><,><!><,><ERROR><,><CSUM><ETX>

Please reference the Error Code section for a list of valid error codes.

If the message is accepted, the Power Supply responds with:

<STX><68><,><ARG1><,><ARG2><,><ARG3><,><CSUM><ETX>

Where:

<ARGx> = Beam#X fault; 0 or 1 in ASCII format

Range:

0 = Off/No Fault

1 = On/Fault

6.6.17 Request System Voltages

Description:

The host requests that the firmware report System Voltages.

Direction:

Host to supply

Syntax:

<STX><69><,><CSUM><ETX>

Response:

If an error is detected, the Power Supply responds with:

<STX>69,!,<ERROR>,<CSUM><ETX>

Please reference the Error Code section for a list of valid error codes.

If the message is accepted, the Power Supply responds with:

<STX>68,<ARG1>,<ARG2>,<ARG3>,<ARG4>,<ARG5>,<ARG6>,<ARG7>,<CSUM><ETX>

Where:

<ARG1> = AC Line Voltage in ASCII 0-4095 format, 0 to 375V

<ARG2> = 24V rail in ASCII 0-4095 format, 0 to 33V

<ARG3> = 15V rail in ASCII 0-4095 format, 0 to 21V

<ARG4> = 5V rail in ASCII 0-4095 format, 0 to 6V

<ARG5> = 3.3V rail in ASCII 0-4095 format, 0 to 5 V

<ARG6> = -15V in ASCII 0-4095 format, 0 to -33V

<ARG7> = Spare rail in ASCII 0-4095 format, 0 to 45V

Example Response:.

Slave number 4 has a Fault.

<STX>69,1302,3047,3008,3426,2711,1857,2243,<ETX>

6.6.18 Reset Faults

Description:

The host requests the firmware to clear latched faults.

Direction:

Host to supply

Syntax:

<STX><74><,><CSUM><ETX>

Response:

If an error is detected, the Power Supply responds with:

<STX>74,!,<ERROR>,<CSUM><ETX>

Please reference the Error Code section for a list of valid error codes.

If the message is accepted, the Power Supply responds with:

<STX>74,\$,<CSUM><ETX>

6.6.19 Program Local/Remote Mode

Description:

The host requests the firmware to switch between Local and Remote Mode.

Direction:

Host to supply

Syntax:

<STX><99><,><ARG><,><CSUM><ETX>

Where:

<ARG> 1 = Remote, 0 = Local in ASCII format

Response:

If an error is detected, the Power Supply responds with:

<STX>99,!,<ERROR>,<CSUM><ETX>

Please reference the Error Code section for a list of valid error codes.

If the message is accepted, the Power Supply responds with:

<STX>99,\$,<CSUM><ETX>

6.7 SPELLMAN TEST COMMANDS

- Program Hardware Version (Hardware setup)
- Program Model number(Hardware setup)
- Store A/D Calibration Value (Hardware setup)
- Request Miscellaneous Analog Readbacks

Contact Spellman High Voltage for details and the syntax of these commands.

6.8 SERIAL COMMAND HANDLING

6.8.1 Command Time Out

The host computer should set a serial time out at approximately 100mS. This allows the DSP to process the incoming message, and transmit a response. The DSP will initiate a reply to incoming messages in approximately 1-2mS, with a worst case of 5mS.

6.8.2 Buffer Flushing

The DSP will flush the incoming serial data buffer every time an STX is received. This provides a mechanism to clear the receive buffer of partial or corrupt messages.

6.8.3 Handshaking

The only handshaking implemented on the host interface, is built in to the implementation of this protocol. That is, the host must initiate all communications. If the supply receives a program command, an acknowledge message is sent back to the host via the "\$" message. If the host does not receive an acknowledge within the time out window, the host should consider the message lost or the device off-line.

Similarly, if the supply receives a request command, the requested data is sent back to the host. If the host does not receive the requested data within the time out window, the host should consider the message lost or the device off-line.

This essentially uses the full-duplex channel in a half-duplex communication mode.

7.0 ERROR CODES

Possible error codes are:

- 1 – Incorrectly formatted packet/message
- 2 – Invalid Command ID
- 3 – Parameter out of range
- 4 – Packet overrun FPGA Register read and write
- 5 – Flash programming error
- 7 – Bootloader failed