

Instruction Manual

SLS SERIES

High Voltage Power Supply

MODEL :
SERIAL# :
DATE :

**SPELLMAN
HIGH VOLTAGE ELECTRONICS
CORPORATION**

475 Wireless Blvd.
Hauppauge, New York, 11788

+1(631) 630-3000*FAX: +1(631) 435-1620*
E-mail: sales@spellmanhv.com
Website: www.spellmanhv.com

IMPORTANT SAFETY PRECAUTIONS

SAFETY

THIS POWER SUPPLY GENERATES VOLTAGES THAT ARE DANGEROUS AND MAY BE FATAL.
OBSERVE EXTREME CAUTION WHEN WORKING WITH THIS EQUIPMENT.

High voltage power supplies must always be grounded.

Do not touch connections unless the equipment is off and the Capacitance of both the load and power supply is discharged.

Allow five minutes for discharge of internal capacitance of the power supply.

Do not ground yourself or work under wet or damp conditions.

SERVICING SAFETY

Maintenance may require removing the instrument cover with the power on.

Servicing should be done by qualified personnel aware of the electrical hazards.

WARNING note in the text call attention to hazards in operation of these units that could lead to possible injury or death.

CAUTION notes in the text indicate procedures to be followed to avoid possible damage to equipment.

Copyright © 2000, Spellman High Voltage Electronics Corporation. All Rights Reserved.
This information contained in this publication is derived in part from proprietary and patent data. This information has been prepared for the express purpose of assisting operating and maintenance personnel in the efficient use of the model described herein, and publication of this information does not convey any right to reproduce it or to use it for any purpose other than in connection with installation, operation, and maintenance of the equipment described.

WICHTIGE SICHERHEITSHINWEISE

SICHERHEIT

DIESES HOCHSPANNUNGSNETZTEIL ERZEUGT LEBENSGEFÄHRLICHE HOCHSPANNUNG.
SEIN SIE SEHR VORSICHTIG BEI DER ARBEIT MIT DIESEM GERÄT.

Das Hochspannungsnetzteil muß immer geerdet sein.

Berühren Sie die Stecker des Netzteiles nur, wenn das Gerät ausgeschaltet ist und die elektrischen Kapazitäten des Netzteiles und der angeschlossenen Last entladen sind.

Die internen Kapazitäten des Hochspannungsnetzteiles benötigen ca. 5 Minuten, um sich zu entladen.

Erden Sie sich nicht, und arbeiten Sie nicht in feuchter oder nasser Umgebung.

SERVICESICHERHEIT

Notwendige Reparaturen können es erforderlich machen, den Gehäusedeckel während des Betriebes zu entfernen.

Reparaturen dürfen nur von qualifiziertem, eingewiesenem Personal ausgeführt werden.

“WARNING” im folgenden Text weist auf gefährliche Operationen hin, die zu Verletzungen oder zum Tod führen können.

“CAUTION” im folgenden Text weist auf Prozeduren hin, die genauestens befolgt werden müssen, um eventuelle Beschädigungen des Gerätes zu vermeiden.

PRECAUTIONS IMPORTANTES POUR VOTRE SECURITE

CONSIGNES DE SÉCURITÉ

CETTE ALIMENTATION GÉNÈRE DES TENSIONS QUI SONT DANGEUREUSES ET PEUVENT ÊTRE FATALES.
SOYEZ EXTRÊMEMENT VIGILANTS LORSQUE VOUS UTILISEZ CET ÉQUIPEMENT.

Les alimentations haute tension doivent toujours être mises à la masse.

Ne touchez pas les connectiques sans que l'équipement soit éteint et que la capacité à la fois de la charge et de l'alimentation soient déchargées.

Prévoyez 5 minutes pour la décharge de la capacité interne de l'alimentation.

Ne vous mettez pas à la masse, ou ne travaillez pas sous conditions mouillées ou humides.

CONSIGNES DE SÉCURITÉ EN CAS DE REPARATION

La maintenance peut nécessiter l'enlèvement du couvercle lorsque l'alimentation est encore allumée.

Les réparations doivent être effectuées par une personne qualifiée et connaissant les risques électriques.

Dans le manuel, les notes marquées « **WARNING** » attire l'attention sur les risques lors de la manipulation de ces équipements, qui peuvent entraîner de possibles blessures voire la mort.

Dans le manuel, les notes marquées « **CAUTION** » indiquent les procédures qui doivent être suivies afin d'éviter d'éventuels dommages sur l'équipement.

IMPORTANTI PRECAUZIONI DI SICUREZZA

SICUREZZA

QUESTO ALIMENTATORE GENERA TENSIONI CHE SONO PERICOLOSE E POTREBBERO ESSERE MORTALI.
PONI ESTREMA CAUTELA QUANDO OPERI CON QUESTO APPARECCHIO.

- Gli alimentatori ad alta tensione devono sempre essere collegati ad un impianto di terra.
- Non toccare le connessioni a meno che l'apparecchio sia stato spento e la capacità interna del carico e dell'alimentatore stesso siano scariche.
- Attendere cinque minuti per permettere la scarica della capacità interna dell'alimentatore ad alta tensione.
- Non mettere a terra il proprio corpo oppure operare in ambienti bagnati o saturi d'umidità.

SICUREZZA NELLA MANUTENZIONE.

- Manutenzione potrebbe essere richiesta, rimuovendo la copertura con apparecchio acceso.
- La manutenzione deve essere svolta da personale qualificato, coscio dei rischi elettrici.
- Attenzione alle **AVVERTENZE** contenute nel manuale, che richiamano all'attenzione ai rischi quando si opera con tali unità e che potrebbero causare possibili ferite o morte.
- Le note di **CAUTELA** contenute nel manuale, indicano le procedure da seguire per evitare possibili danni all'apparecchio.

Table of Contents

PAGE

1. INTRODUCTION

1.1	Description of the SLS Series	1
1.2	Standard Features	2
1.2.1	Remote Operating Features	2
1.2.2	System Status and Fault Diagnostic Display	2
1.3	Options	3
1.4	Interpreting the Model Number	4

2. INSPECTION & INSTALLATION

2.1	Initial Inspection	5
2.2	Mechanical Installation	5

3. OPERATING INSTRUCTIONS

3.1	Operation	7
3.2	Standard Features	8

4. PRINCIPLES OF OPERATION

4.1	Chassis	17
4.2	Line Rectification and Filtering	17
4.3	Inverter	18
4.4	High Voltage Transformer	18
4.5	High Voltage Stack Assembly	18
4.6	Control/Power PWB	18
4.7	Front Panel Assembly	19
4.8	Options	19

5. OPTIONS

5.1	Adjustable Overload Trip	20
5.2	220Vac Single Phase Input	20
5.3	No Slow Start	20
5.4	Non-Standard Slow Start	20
5.5	Arc Trip	20
5.6	Instant On	20
5.7	External Fault Relay	21

5.8	Custom Designed Models	21
6. MAINTENANCE		
6.1	Periodic Servicing	22
6.2	Performance Test	22
6.3	High Voltage Dividers	22
7. REPLACEMENT PARTS		
7.1	Replacement Parts	23
7.2	Correspondence and Ordering Spare Parts	23
8. FACTORY SERVICE		
8.1	Warranty Repairs	24
8.2	Factory Service Procedures	24
8.3	Ordering Options and Modifications	24
8.4	Shipping Instructions	24

LIST OF FIGURES

Figure 2.1	SLS Series Dimensions.....	6
Figure 3.1	SLS Series Typical Operating Set Up.....	10
Figure 3.2A	Wiring Diagram for Remote Programming via Voltage Source.....	12
Figure 3.2B	Wiring Diagram for Remote Programming via External Resistance.....	12
Figure 3.3	Remote Monitor Test Points	13
Figure 3.4	Remote Control of High Voltage On and Off	13
Figure 3.5	External Inhibit Interface Circuit	14
Figure 3.6	External Interlock Interface Circuit	14
Figure 3.7	Remote High Voltage On and Off Indicator Circuit.....	15
Figure 3.8	Remote Indicators Interface.....	16
Figure 5.7	Instant On Option.....	21

LIST OF TABLES

Table 1.1	SLS Options	3
Table 3.1	System Cables	11
Table 3.2	Rear Panel Interface 25 pin Mini D Connector Pin Out.....	12

APPENDIX

- A. Specification Controls (Custom Models Only)

Chapter 1

INTRODUCTION

1.1 Description of the SLS Series

The SLS Series of high voltage power supplies provides very well regulated, low ripple high voltage in a highly efficient, compact design. The improvements in size and performance over traditionally high voltage power supplies are due to the resonant topology and unique control circuitry of the SLS Series. A proprietary control system maintains high frequency over the operating output range. The combination of the proprietary control and protection circuitry enables the supplies to operate under arcing and extreme transient conditions without damage or interruptions.

The SLS Series offer outputs from 160kV to 360kV via an inverter chassis and separate high voltage “stack” assembly. The necessity of the stack is simple, as output voltages increase to 160kV and beyond, economical and reliable cable/connector assemblies become less available and more problematic to incorporate. The solution is to remove the cable/connector assembly and to make the output voltage available via the top of a separate air insulated high voltage stack assembly. SLS units typically have two assemblies: the inverter chassis and the air insulated high voltage stack.

Danger – Electrocuting Hazard!

The top corona dome assembly of the SLS is at high voltage. It is the responsibility of the user to:

- a) Make appropriate electrical connection to the corona dome assembly.
- b) Assure the corona dome assembly is adequate to suppress corona in their particular usage and application, additional customer provided corona relief might be required.
- c) Assure adequate air insulation spacings are used in the setup and mounting of the stack assembly (minimum of 1 inch for each 10kV of high voltage).
- d) Make certain the entire high voltage stack assembly is contained in a grounded, protective [Faraday Cage](#) with an interlocked access door.

SLS units generate lethal voltages; they require appropriate high voltage safety knowledge to safely setup and use. If you are not properly trained and qualified: STOP! DO NOT PROCEED! DO NOT USE THIS EQUIPMENT!



1.2 Standard Features

The SLS Series incorporates several standard features designed to optimize user satisfaction and safety.

- **SLOW START:** This feature provides a gradual increase in high voltage until the preset operating point is reached. The default slow start time is set for 6 seconds. Other slow start times are available as an option at time of order.
- **ARC DETECT / ARC QUENCH / ARC COUNT:** These features allow the user to tailor the power supply to meet specific needs in dynamic load applications. If an arc occurs, the output is inhibited for approximately one second, and then the output is ramped up to the preset level with the slow-start circuitry. See Chapter 3 for operating details and information for user customization of these features.
- **INTERNAL FAULT PROTECTION:** The SLS Series continually monitors internal circuits critical to the proper operation of the power supply. In the event that one of these circuits does not function correctly, the fault detection circuit latches the appropriate fault on the front panel display and turns off the output and reverts the unit to the POWER DOWN mode, see Chapter 3 for details.
- **INDICATOR LAMPS:** HIGH VOLTAGE OFF AND HIGH VOLTAGE ON indicators is provided.

1.2.1 Remote Operating Features

- **REMOTE PROGRAMMING:** Allows remote adjustment of the output voltage and current via an external voltage source.
- **REMOTE MONITOR:** Allows remote monitoring of the output voltage and current.
- **REMOTE HIGH VOLTAGE CONTROL:** Allows remote control of HIGH VOLTAGE ON and HIGH VOLTAGE OFF. Signals are also provided for remote indication of HV ON or HV OFF status.
- **EXTERNAL INHIBIT:** A control signal that will inhibit the high voltage output is provided on the external interface. A logic low or ground will inhibit the high voltage output and a logic high or open; will restore the high voltage output to the preset level.

NOTE: The External Inhibit circuit should NOT be used for protection against injury or for safety interlock. See External Interlock for this type of safety control.

- **EXTERNAL INTERLOCK:** Interlock connections are provided on the external interface on the rear of the chassis for connection to a safety switch. The unit will not operate unless the interlock circuit is closed. During high voltage operation, opening the interlock circuit will cause the High Voltage to shut off. This circuit should be used for safety interlock circuits.

1.2.2 System Status and Fault Diagnostic Display

“Dead Front” type indicators provide the user complete information of system operation and fault conditions. If a fault occurs, the power supply will revert to the POWER DOWN mode. This is indicated by both the red HV ON and green HV OFF lamps turning off and a latched fault being displayed on the fault diagnostic panel. To reset, depress the green HV OFF switch or cycle the AC power.

- **VOLTAGE (CONTROL):** Indicates the output voltage regulator circuit is maintaining voltage regulation.
- **CURRENT (CONTROL):** Indicates the output current regulator circuit is maintaining current regulation.
- **HV INHIBIT:** Indicates that the high voltage supply is being inhibited by either the EXTERNAL INHIBIT or internal protection circuitry.
- **INTLK CLSD:** Indicates the EXTERNAL INTERLOCK connections are in the closed position. This also indicates closure of internal power supply interlocks.
- **INTKL OPEN:** Indicates the EXTERNAL INTERLOCK connections are in the open position. This also indicates opening of internal power supply interlocks, high voltage cannot be generated.
- **OVERVOLT:** Indicates the overvoltage protection circuitry has caused the power supply to turn off. Overvoltage protection is internally set to 110% of the maximum rated output voltage.
- **OVERCURR:** Indicates the output current has exceeded the programmed current trip level when the AOL (Adjustable Overload Trip) or the OL (Overload Trip) options are installed.
- **ARC:** Indicates that an arc has occurred within the previous one second or that the ARC COUNT/TRIP has shutdown the power supply.

- **RGLT ERR:** Indicates a failure in the voltage or current regulation circuitry. This fault usually occurs when there is a lack of output power to maintain regulation.

The options available are listed in Table 1.1. See Section 5 for more information on these options along with operating and set-up instructions. With few exceptions, these options and modifications can be retrofitted to your power supply at the factory. For price and retrofit arrangements, contact the Spellman Sales Department.

1.3 Options

AOL	Adjustable Overload Trip (0-103%)
OL	Overload Trip (103%)
APT	Adjustable Power Trip
AT	Arc Trip
CPC	Constant Power Control
SS(X)	Non-Standard Slow Start (X = seconds)
NSS	No Slow Start
IO	Instant ON
(200)	200Vac, $\pm 10\%$, three phase input voltage
DPM4	4-1/2 Digit (± 1 LSD) Digital Panel Meter
SL	Slides
EFR	External Fault Relay
BFP	Blank Front Panel

Table 1.1 SLS Options

1.4 Interpreting the Model Number

The model number of the power supply describes its capabilities. After the series name is:

1. the maximum voltage (in kV).
2. the polarity of the unit: positive (P) or negative (N).
3. the maximum output (in watts).
4. the option codes for all options that are included.

Custom units have an X number after the option codes.

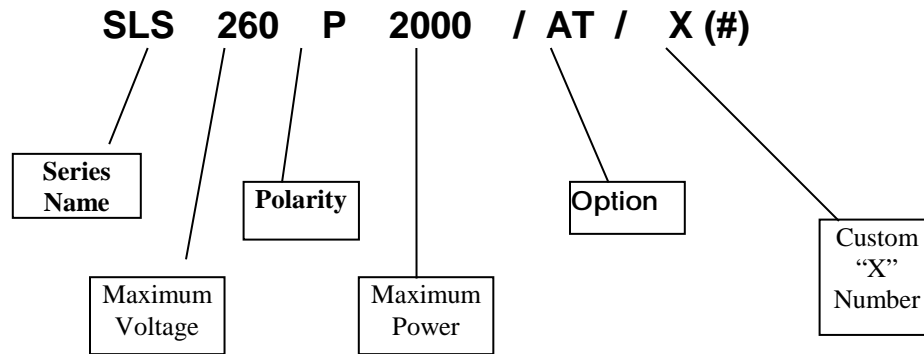

Chapter 2

INSPECTION & INSTALLATION

Initial inspection and preliminary checkout procedures are recommended. For safe operation, please follow the step-by-step procedures described in Chapter 3, Operating Systems.

2.1 Initial Inspection

Inspect the package exterior for evidence of damage due to handling in transit. Notify the carrier and Spellman immediately if damage is evident. Do not destroy or remove any of the packing material used in a damaged shipment.

After unpacking, inspect the assemblies for visible damage.

Standard Spellman SLS Series high voltage power supplies and components are covered by warranty. Custom and special order models (with an X suffix and the model number) are also covered by warranty.

2.2 Mechanical Installation

Units in the SLS Series are typically comprised to two parts: the inverter rack and the high voltage output stack.

Inverter Rack:

The inverter rack has front panel holes for standard EIA rack mounting, it is recommended to support the chassis by guides or slides. Slides are available for ease of servicing (SL option).

High Voltage Output Stack:

The high voltage output stack is an air insulated high voltage multiplier assembly with ground at the bottom of the mounting plate assembly and the high voltage output

at the top of the corona dome assembly. The high voltage output stack is typically vertically mounted and must be mechanically secured via the grounded mounting plate. Customers must make the appropriate high voltage connection to the stack via mechanical/electrical means at the uppermost corona dome assembly.

Danger – Electrocuting Hazard!

The top corona dome assembly is at high voltage. It is the responsibility of the user to:

- a) Make appropriate electrical connection to the corona dome assembly.
- b) Assure the corona dome assembly is adequate to suppress corona in their particular usage and application, additional customer provided corona relief might be required.
- c) Assure adequate air insulation spacings are used in the setup and mounting of the stack assembly (minimum of 1 inch for each 10kV of high voltage).
- d) Make certain the entire high voltage stack assembly is contained in a grounded, protective [Faraday Cage](#) with an interlocked access door.

SLS units generate lethal voltages; they require appropriate high voltage safety knowledge to safely setup and use. If you are not properly trained and qualified: **STOP! DO NOT PROCEED! DO NOT USE THIS EQUIPMENT!**

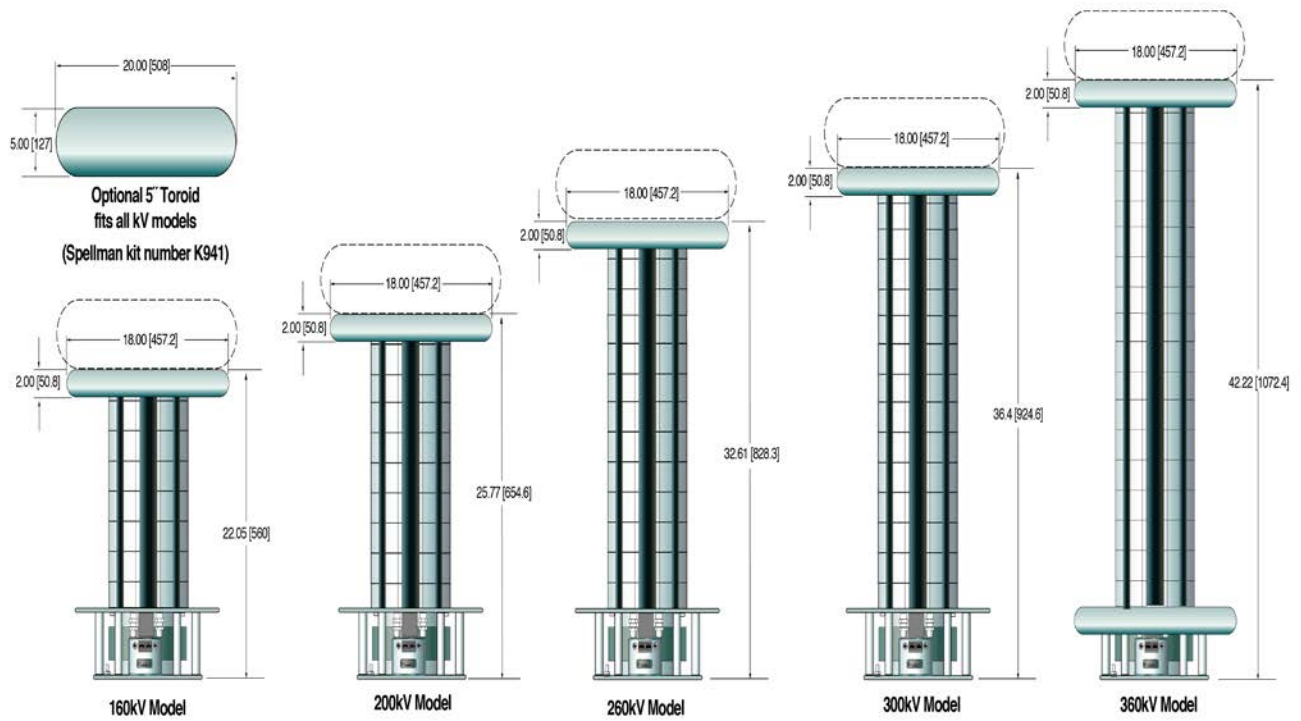

Figure 2.1 – SLS Series Typical Dimensions
(SLS200P2000 shown)

Chapter 3

OPERATING INSTRUCTIONS

3.1 Operation

WARNING

THIS EQUIPMENT GENERATES DANGEROUS VOLTAGES THAT MAY BE FATAL.

PROPER GROUNDING OF ALL HIGH VOLTAGE EQUIPMENT IS ESSENTIAL.

WARNING

BEFORE CONNECTING THE POWER SUPPLY TO THE AC LINE, FOLLOW THIS STEP BY STEP PROCEDURE.

DO NOT CONNECT THE POWER SUPPLY TO THE AC LINE UNTIL STEP G IS REACHED.

Failure to follow these procedures may void the warranty.

- A) Insure the Circuit Breaker is in the OFF position (0).
- B) Check the input voltage rating on the nameplate of the supply and make certain that this is the rating of the available power source. Standard SLS Series units operate on 220Vac, three phase.
- C) **PROPER GROUNDING TECHNIQUES:** The E1 ground stud on the rear of the inverter chassis must be connected to whatever customer system ground is used: cold water pipe ground, electrical conduit ground, steel building girder ground, ground rod ground, etc. This customer provided system ground cable should be a heavy gauge, mechanically secure connection. See Figure 3.1 for a typical operating set-up.

The “bottom end” of the load must be connected to the ground stud on the bottom of high voltage stack baseplate using a heavy gauge and mechanically secure customer provided load return cable.

SLS units are provided with a four conductor line cord (three phases and safety ground). No specific phase orientation is required.

- D) Electrically/mechanically attach the high voltage stack assembly corona dome to the load as seen fit for the application on hand.
 - E) **OPTIONS NOTE:** See Section 5 for hook-up and operating instructions for the options on your unit. Custom models may also require set-up changes.
 - F) For initial turn-on, rotate the KILOVOLT control fully counter-clockwise to the zero voltage position. Rotate the MILLIAMPERES control fully clockwise to the maximum position.
 - G) The input power cable may now be connected to the AC power line.
 - H) Switch the front panel circuit breaker to the ON position (I). (If the supply is to be turned off for an extensive period of time, the line cord should be disconnected). The front panel lights should illuminate. The unit is now in the HIGH VOLTAGE OFF mode. The green HIGH VOLTAGE OFF light should be illuminated.
 - I) Depress and hold the green HIGH VOLTAGE OFF switch. The front panel meters will now read the preset value of the KILOVOLT dial and the MILLIAMPERES dial (or remote programming voltages, if used). To preset the desired level of current and voltage during operation, hold in the green HIGH VOLTAGE OFF switch and rotate the appropriate dial while noting the corresponding meter reading. Release the green HIGH VOLTAGE OFF switch.
- NOTE:** No actual output is being produced at this stage.
- J) Depress the red HIGH VOLTAGE ON switch. The switch should illuminate and the output will slow start to the preset level output voltage and/or output current.

NOTE: The SLS Series is equipped with a slow start circuit that ramps the output up to its maximum setting in approximately 6 seconds after the red HIGH VOLTAGE ON switch is depressed.

- K) To terminate the generation of output power, depress the green HIGH VOLTAGE OFF switch. In the HIGH VOLTAGE OFF mode the power supply's fault, front panel monitoring and interface circuits are still active.
- L) To turn off the power supply, turn the circuit breaker to the off position (0).

NOTE: If a power supply or system fault occurs, the unit will revert to the POWER DOWN mode, where the output power will be turned off. The green HV OFF lamp will not be illuminated; a red latched fault should be indicated on the fault diagnostic panel. To clear and reset the fault, depress the green HV OFF switch or cycle the AC input power.

WARNING

AFTER TURN OFF, DO NOT TOUCH ANYTHING CONNECTED TO THE HV OUTPUT UNTIL THE CAPACITANCE HAS BEEN DISCHARGED!

LOAD CAPACITANCE MAY BE DISCHARGED BY SHORTING TO GROUND WITH A SAFETY DISCHARGE STICK.

WARNING

THE VOLTMETER ON THE POWER SUPPLY FRONT PANEL DOES NOT READ THE OUTPUT VOLTAGE WHEN THE AC LINE POWER IS TURNED OFF, EVEN IF A CHARGE STILL EXISTS ON THE LOAD.

CAUTION

ALWAYS OPERATE THE UNIT WITH THE CHASSIS TOP COVER ON.

A fan maintains safe operating temperature in the inverter chassis by drawing air over the circuit components. The cover must be on in order to direct the air flow over the areas that need cooling. In operation, the unit must be placed so that the air intake and the fan exhaust are clear of obstructions.

3.2 Standard Features

Whenever possible, electrical isolation should be used when interfacing with any high voltage power supply. For power control signals such as EXTERNAL INTERLOCK, HIGH VOLTAGE OFF, and HIGH VOLTAGE ON, isolated relay contacts should be used. For status and control signals such as HIGH VOLTAGE ON, HIGH VOLTAGE OFF, and EXTERNAL INHIBIT, etc., opto-isolation should be used. If possible, analog programming and monitoring signals should be isolated via analog isolation amplifiers. Spellman application engineers are available to assist in answering any questions. All interface cables should be properly shielded. All power supply signals should be referenced to the power supplies signal ground on the external interface connector.

- **REMOTE PROGRAMMING:** Allows remote adjustment of the output voltage and current via an external voltage source. In local control (front panel control), jumpers are installed on the 25 pin D external interface connector J3 at the rear of the chassis between J3-10 and J3-11 for voltage control and between J3-8 and J3-9 for current control.

For remote programming, the jumpers are removed and a positive polarity, ground referenced signal, from 0Vdc to 10Vdc, is applied to the appropriate terminals. Programming signals should be referenced to J3-1, signal ground. By adjusting the voltage source from 0Vdc (zero output) to 10Vdc (full rated output), the desired output can be selected. See Figure 3.2A on page 13 for the wiring diagram and specifications.

An alternate method of controlling the output remotely is by using external resistance, such as a potentiometer or a resistor network. For remote control the jumpers are removed and the desired resistor configuration installed. See Figure 3.2B on page 13 for the wiring diagram.

- **REMOTE MONITOR:** Test points are made available at the 25 pin D connector on the rear of the chassis for monitoring the voltage and current output. The test points are always positive regardless of the output polarity where 0Vdc to 10Vdc equals 0 to 100% of the output, $\pm 1\%$. Test points have an output impedance of 5k ohms. See Figure 3.3 on page 14 for the test point designation.

- **REMOTE CONTROL:** Remote control of the HIGH VOLTAGE ON and HIGH VOLTAGE OFF can be accomplished via the rear panel interface. HIGH VOLTAGE OFF and HIGH VOLTAGE ON can be controlled by momentary normally closed and normally open contacts respectively. See Figure 3.4 on page 14 for the recommended interface.
- **EXTERNAL INHIBIT:** Allows the user to inhibit the power supply output without switching HIGH VOLTAGE OFF control. This circuit can be used to generate fast slewing output waveforms or control of high voltage generation as in laser and capacitor discharge applications. The maximum inhibit rate should not exceed 5Hz. Consult the factory for higher repetition rates or high pulse load applications. See Figure 3.5 on 15 for the recommended interface circuit.

WARNING

IT IS EXTREMELY DANGEROUS TO USE THIS INHIBIT CIRCUIT TO STOP HIGH VOLTAGE GENERATION FOR THE PURPOSE OF SERVICING OR APPROACHING ANY AREA OR LOAD CONSIDERED UNSAFE DURING NORMAL USE.

- **EXTERNAL INTERLOCK:** External interlock connections are provided on J3-3 and J3-4 on the 25 pin D connector for connection to a safety interlock switch. The unit will not operate unless the interlock circuit is closed. If the interlock is not being used, the jumper installed on the two pins before shipping must be in place. If the jumper is missing, or there is an opening between the interlock terminals high voltage cannot be generated. During high voltage operation if these connections are opened the unit will revert to the HIGH VOLTAGE OFF mode. Subsequent closing of the interlock circuit will NOT

return the unit to the HIGH VOLTAGE ON mode. This must be accomplished by depressing the HIGH VOLTAGE ON switch. See Figure 3.6 on page 15 for the recommended interface circuits.

- **ARC DETECT / ARC QUENCH / ARC COUNT:** The ARC INTERVENTION circuit senses dynamic arcing or discharge conditions present at the output load. If an arc occurs the output is inhibited for one second, then the output is ramped up to the previous set level. This ramp is based on the standard six second slow start feature. The SLOW START ramp circuit may be disabled by removing CR32 on the Control/Power Pwb. Caution should be observed if this feature is disabled. Discharge rates of greater than 1Hz may cause excessive power dissipation in the power supply's output limiting resistors, voiding the warranty.

The ARC COUNT feature will allow the user to program the ARC fault parameters. The ARC indicator on the front panel will illuminate for approximately one second after each arc has occurred. The power supply can be programmed to trip into the POWER DOWN mode if a single arc occurs (AT Option).

The default setting is to trip the power supply into the POWER DOWN mode if 8 arcs occur within a twenty second period.

- **REMOTE HIGH VOLTAGE ON & REMOTE HIGH VOLTAGE OFF:** Signals are provided for remote monitoring of the HIGH VOLTAGE ON and HIGH VOLTAGE OFF status. See Figure 3.7 on page 16 for recommended interface.
- **REMOTE MODE INDICATORS:** Signals are provided for remote indication of the control mode status: voltage control or current control. See Figure 3.8 on page 17 for the recommended interface.

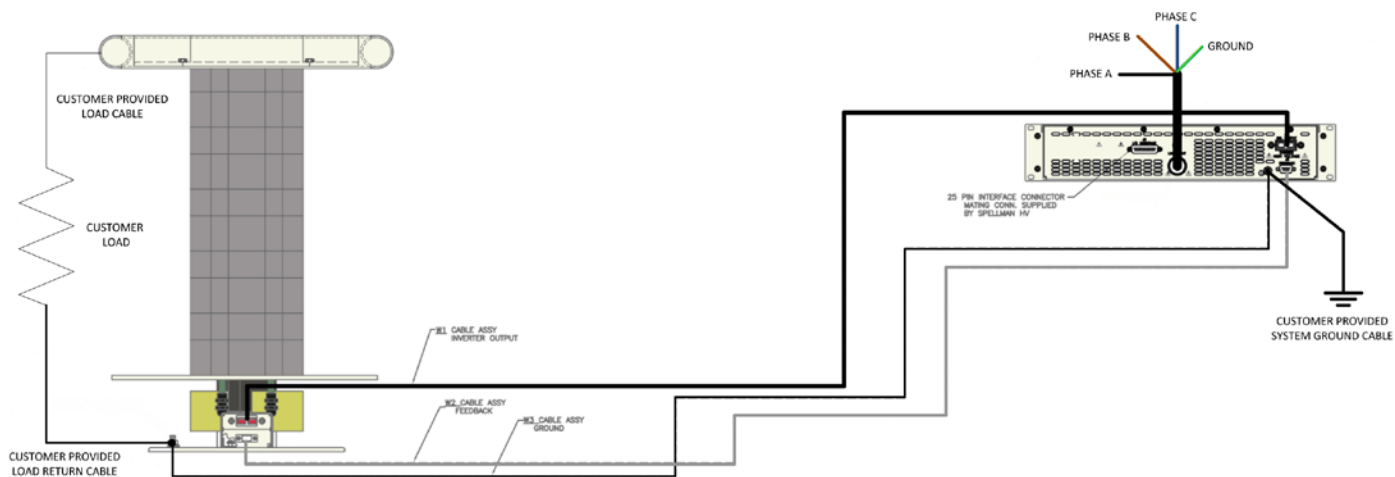

Figure 3.1 -- Typical Operating Setup

Item	Description
W1	Inverter Output Cable
W2	Feedback Cable
W3	Ground Cable
4	Load Return Cable (customer provided)
5	System Ground Cable (customer provided)

Table 3.1 System Cables

	J3	SIGNAL	SIGNAL PARAMETERS
	1	Power Supply Common	Signal Ground
	2	External Inhibit	Ground = Inhibit, Open = HV ON
	3	External Interlock	+15V at Open, <15mA at Closed
	4	External Interlock Return	Return For External Interlock
	5	Current Monitor	0 to 10V = 0 to 100% Rated Output
	6	kV Test Point	0 to 10V = 0 to 100% Rated Output
	7	+10V Reference	+10.24V, 1mA Max
	8	Remote Current Program In	0 to 10V = 0 to 100% Rated Output
	9	Local Current Program Out	Front Panel Program Voltage
	10	Remote Voltage Program In	0 to 10V = 0 to 100% Rated Output
	11	Local Voltage Program Out	Front Panel Program Voltage
	12	EFR (Common)	Optional External Fault Relay
	13	EFR (Normally Open)	Optional External Fault Relay
	14	Local HV Off Out	+15V at Open, < 25mA at Closed. Connect to HV OFF For FP Operation
	15	HV OFF	15V at Open, < 25mA at Closed. Connect to Local HV Off Out For FP Operation
	16	Remote HV ON	+15V, 10mA Max = HV ON
	17	Remote HV OFF Indicator	0 = HV ON, +15V, 10mA Max = HV OFF
	18	Remote HV ON Indicator	0 = HV OFF, +15V, 10mA Max = HV ON
	19	Remote Voltage Mode	Open Collector 50V Max, 10mA Max On = Active
	20	Remote Current Mode	Open Collector 50V Max, 10mA Max On = Active
	21	spare	spare
	22	Remote PS Fault	0 = Fault, +15V, 0.1 Ma Max = No Fault
	23	+15V Output	+15V, 100mA Max
	24	Power Supply Common	Signal Ground
	25	Shield Return	Chassis Ground

Table 3.2 - Rear Panel Interface 25 pin Mini D

Voltage Source 0-10V = 0-100% of Rated Output

It is recommended that analog signals be isolated via isolation amplifiers.

All cables should be shielded with the shields being returned to the chassis ground of the High Voltage Power Supply.

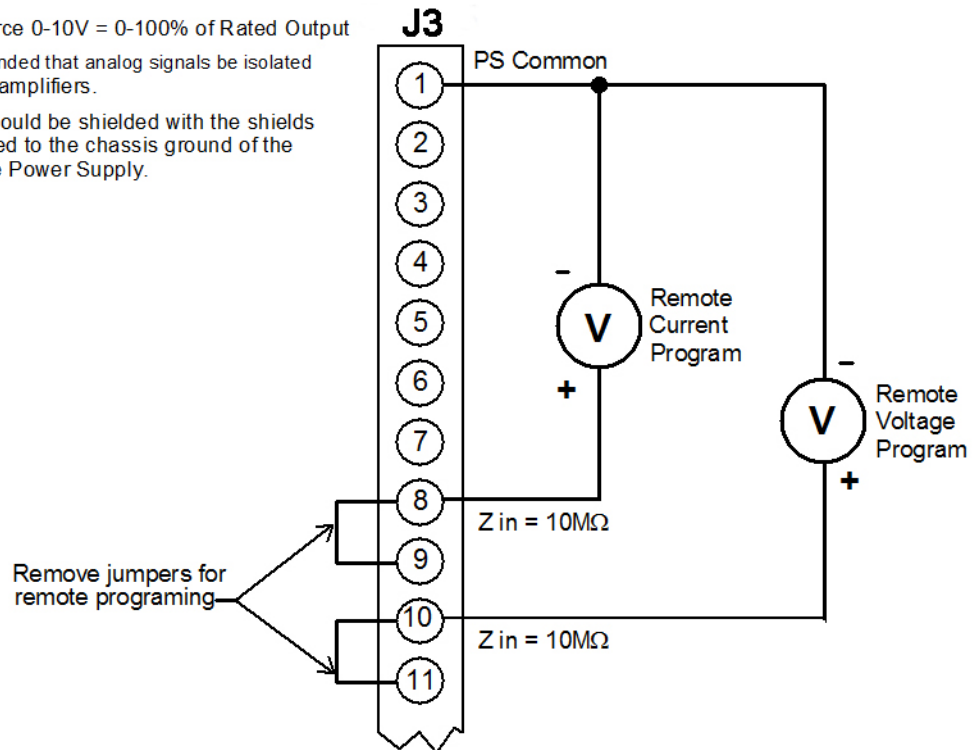

Figure 3.2A -- Wiring Diagram for Remote Programming via Voltage

Fully Counterclockwise = Zero Output
Fully Clockwise = 100% of Rated Output

All cables should be shielded with the shields being returned to the chassis ground of the High Voltage Power Supply.
If connections to external potentiometers are excessively long (>10ft), motorized potentiometers are recommended.

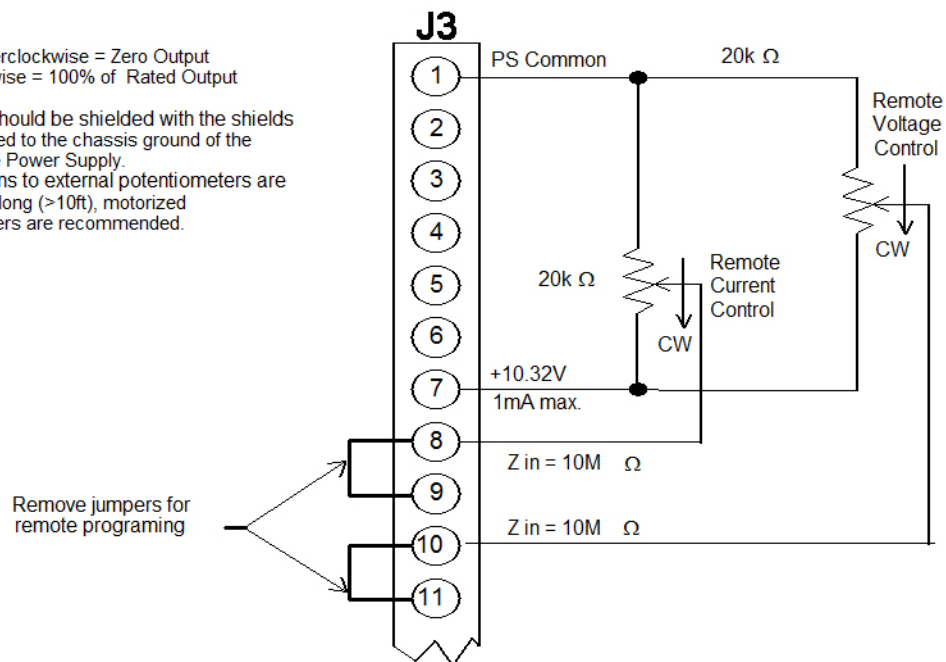
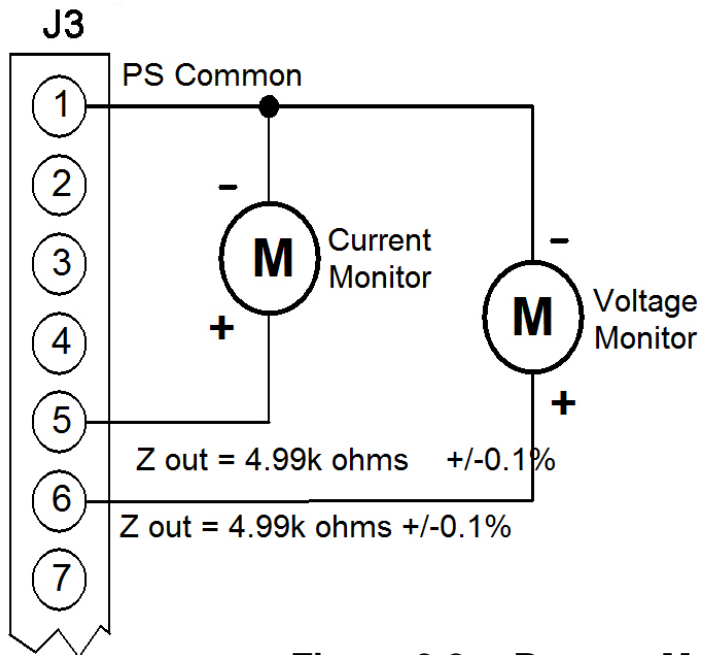
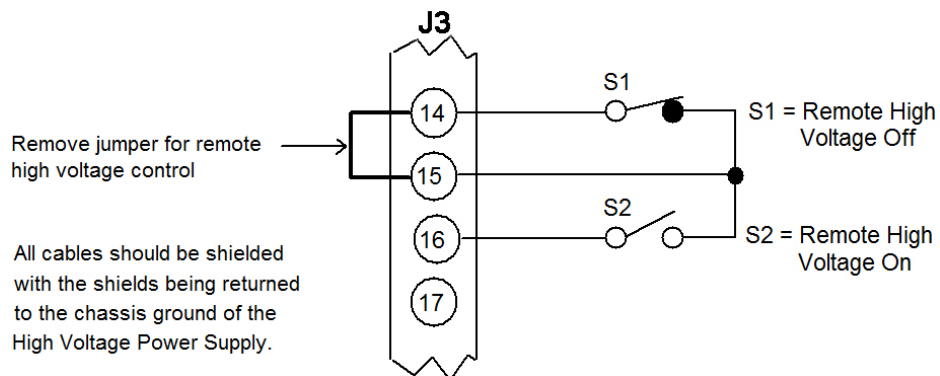

Figure 3.2B -- Wiring Diagram for Remote Programming via External Potentiometers



It is recommended that analog signals be isolated via isolation amplifiers. All cables should be shielded with the shield being returned to the chassis ground of the high voltage power supply.

Figure 3.3 -- Remote Monitor Test Points



S1 must be closed to enable HIGH VOLTAGE. Momentary closure of S2 will enable HIGH VOLTAGE ON. Opening S1 will disable HIGH VOLTAGE ON and switch the unit to the HIGH VOLTAGE OFF mode.

It is recommended to use relay contacts for S1 and S2. Relays should be located as close as possible to the high voltage power supply. Coils should be driven from isolated sources. Signals are at 15Vdc, 25mA max., and are only to be used for contact closure.

Figure 3.4 Remote Control Of High Voltage On and High Voltage Off Interface

The transistor should be located as close as possible to the power supply

All cables should be shielded with the shields being returned to the chassis ground of the High Voltage Power Supply.

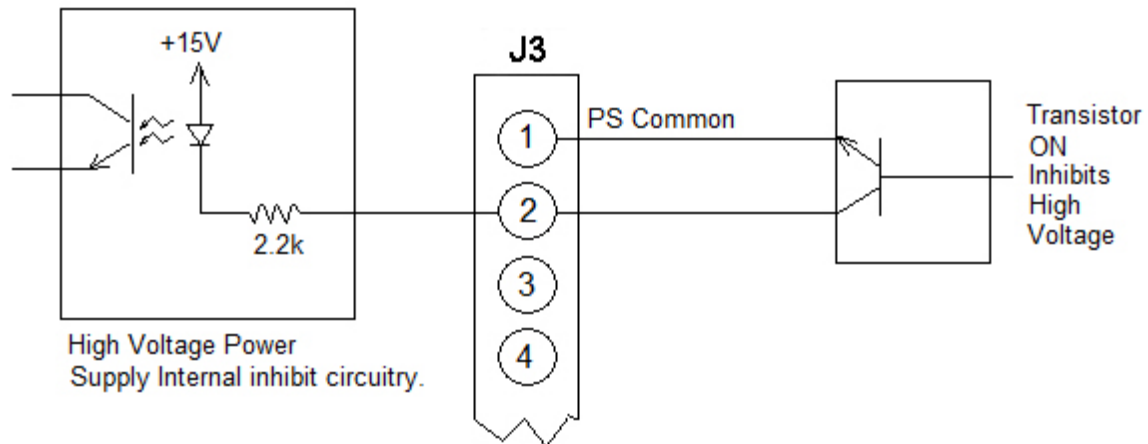
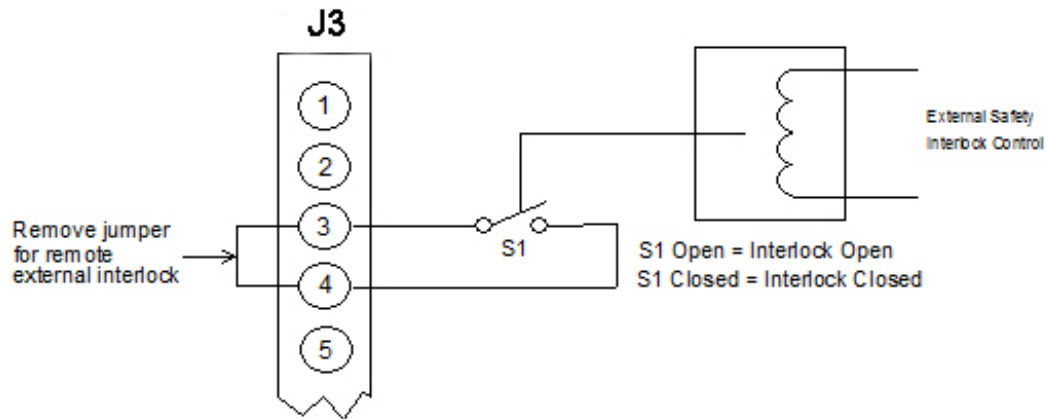

Figure 3.5 -- External Inhibit Interface Circuit

Relay contacts are recommended for S1. The relay should be located as close as possible to the power supply. Signals are at 15Vdc, 25mA max and are only to be used for contact closure.



All cables should be shielded with the shields being returned to the chassis ground of the High Voltage Power Supply.

Figure 3.6 -- External Interlock Interface

12Vdc lamps or relay coils may replace opto-couplers.
 Opto-couplers, lamps or relays should be located as close
 as possible to the high voltage power supply.
 All cables should be shielded with the shields being
 returned to the chassis ground of the High Voltage Power Supply.

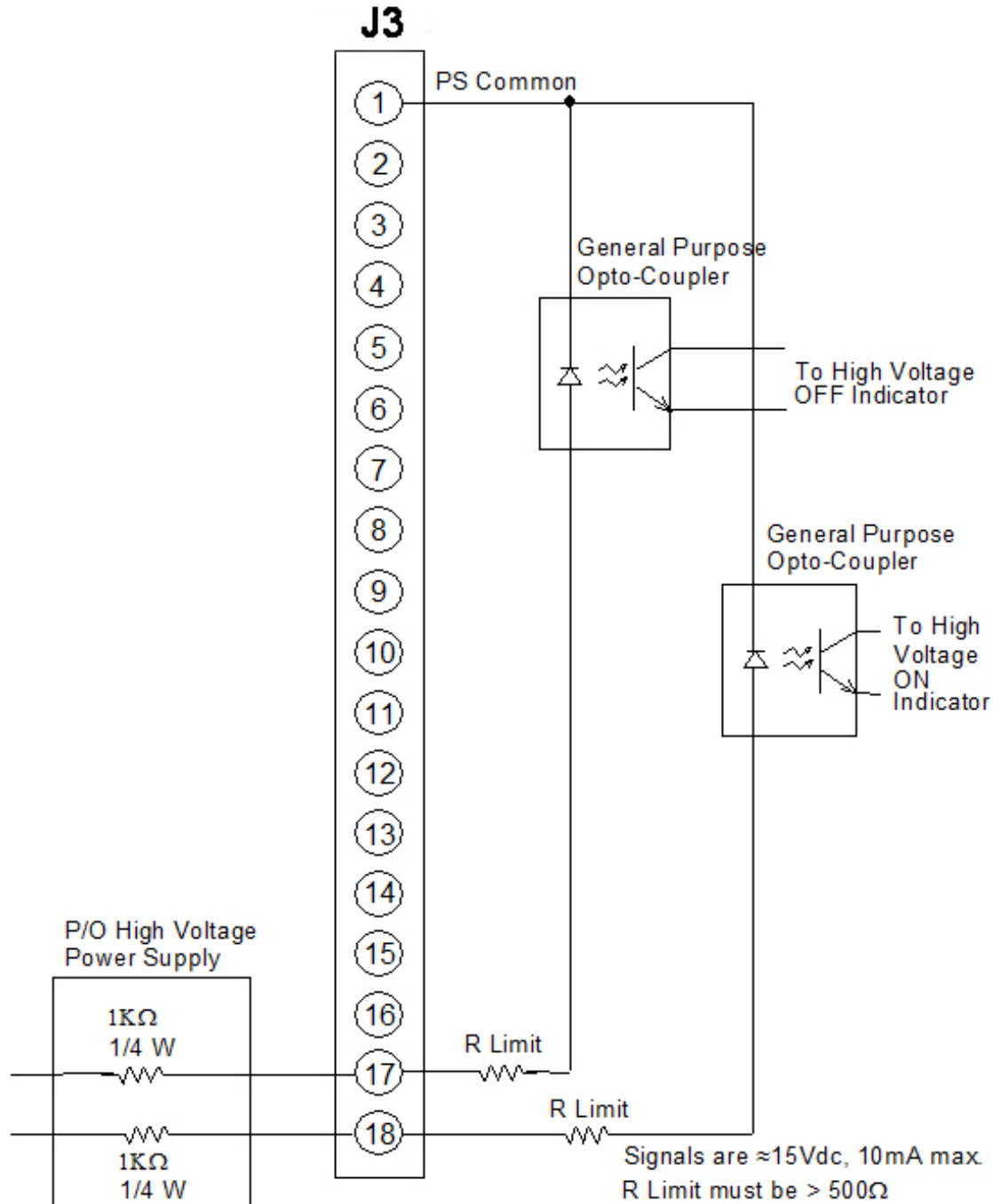

Figure 3.7 -- Remote High Voltage On and Remote High Voltage off Indicator

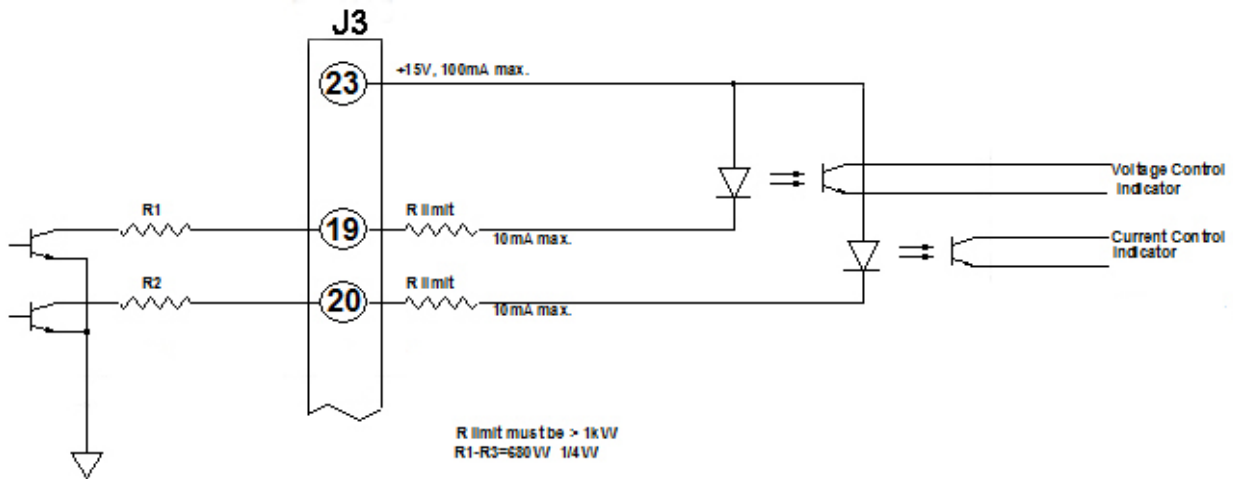

Figure 3.8 -- Remote Mode Indicators Interface

Chapter 4

PRINCIPLES OF OPERATION

The SLS Series of high voltage power supplies utilizes sophisticated power conversion technology. A variety of analog, digital and power conversion techniques are used. The intention of the Principles of Operation is to introduce the basic function blocks that comprise the SLS power supply. For details on a specific circuit, consult Spellman's Engineering Department.

The SLS power supply is basically a low voltage AC to high voltage DC power converter. Within the power supply, conversions of AC to DC, then to high frequency AC, then to high voltage DC take place. By reviewing further the sub-assemblies, a basic understanding of the process can be gained.

4.1 Chassis

The SLS Series is a compact, high efficiency, high voltage power supply. The unit can supply up to 2000 watts of DC power. Output voltages from 160kV to 360kV can be generated.

WARNING

The energy levels used and generated by the power supply can be lethal! Do not attempt to operate the power supply unless the user has a sufficient knowledge of the dangers and hazards of working with high voltage. Do not attempt to approach or touch any internal or external circuits or components that are connected or have been connected to the power supply. Be certain to discharge any stored energy that may be present before and after the power supply is used. Consult IEEE recommended practices for safety in high voltage testing [#510-1983](#).

4.2 Line Rectification And Filtering

Basic three phase rectification and capacitive filtering provides the DC rail voltage for the high frequency inverter.

Circuit protection is provided by a front panel fast acting magnetic trip type circuit breaker. The line input is connected directly to the line side of the circuit breaker whereas the load side is connected to the CONTROL/POWER PWB. The load side of the breaker is also connected to a step-down type line transformer which provides voltages for housekeeping and control circuit power.

WARNING

LINE VOLTAGE IS PRESENT WHENEVER THE POWER SUPPLY IS CONNECTED TO EXTERNAL LINE VOLTAGES. BE SURE TO DISCONNECT THE LINE CORD BEFORE OPENING THE UNIT.

ALLOW 5 MINUTES FOR INTERNAL CAPACITANCE TO DISCHARGE BEFORE REMOVING ANY COVER.

When the circuit breaker is ON, voltage is applied to an isolated three phase bridge rectifier, which contains the diodes used for line voltage rectification. The output of this bridge rectifier is connected to a capacitive filter to reduce the line related ripple components. The filter capacitors are initially charged through a resistive inrush limiter to prevent nuisance tripping of the circuit breaker during initial turn on.

Approximately 3 seconds after the circuit breaker is closed, a relay is energized to short the resistive inrush limiter. This ± 150 Vdc rail voltage is supplied to the high frequency inverter.

The DC rails are connected to the high frequency rail capacitors. These capacitors are high frequency, low loss type, which provides the energy storage for the high frequency inverter.

4.3 Inverter

The inverter is a series resonant, series/parallel loaded topology. A proprietary control scheme is used for regulating the power generated from the resonant IGBT inverter. These power devices provide high frequency switching to control the resonant current flow. The typical resonant operating period is approximately 10 microseconds. The gate control for the IGBT's is provided by the circuitry located on the CONTROL/POWER PWB. The CONTROL/POWER PWB also provides circuitry for sensing simultaneous conduction and overcurrent conditions in the inverter.

4.4 High Voltage Transformer

The output of the Inverter is connected to the primary of the step up High Voltage Transformer. The High Voltage Transformer is located in the "stack" assembly beneath the upper grounded baseplate. The inverter output is typically an AC high frequency signal about 300 volts in magnitude. Due to the high frequency, high current flowing in this cable it is not recommended to try to modify and/or lengthen the inverter drive cable that connects the inverter rack and the high voltage stack.

4.5 High Voltage Stack Assembly

The High Voltage Stack Assembly will vary depending upon the specific model of SLS ordered. The stack is comprised of an assembly of encapsulated interlocking high voltage multiplier "wafers", an encapsulated filter assembly and an encapsulated voltage feedback divider.

Each encapsulated high voltage multiplier wafer is rated for 20kV, so an SL160P2000 would use eight (8) interlocking multiplier wafers to generate the required output voltage.

The output filter assembly attenuates ripple by virtue of an R-C type filter. The voltage feedback divider provides a representative sample of the actual high voltage output for regulation and monitoring purposes. Current feedback for regulation and monitoring is provided by a current sense resistor connected at the low voltage end of the multiplier stack assembly.

4.6 Control/Power PWB

The majority of control circuits for power supply operation are located on the CONTROL/POWER PWB. +15Vdc, -15Vdc, and +10Vdc is generated on the CONTROL/POWER PWB. High Voltage On/Off control is accomplished by relay K3, and its associated circuitry. Interlock control is provided by relay K4.

Voltage feedback from the high voltage divider is sent to the control board via a mass terminated ribbon cable. Gain adjustment is provided on the HV FDBK PWB. The KV feedback signal is sent to the front panel DVM and to the REAR PANEL interface 25 pin D connector for remote monitoring. Relay K2 provides switching between feedback and program signal for the front panel DVM's. This allows the user to preset the desired output before energizing high voltage.

Program voltages are typically ramped up to set level by a slow start circuit.

An arc intervention circuit provides sensing, quench and indications of arc conditions. Consult the chapter three for a detailed description of the arc sense control.

Current feedback is generated via the use of a current sense resistor located on a printed circuit board in the High Voltage Stack Assembly. Calibrated feedback is then sent to the applicable circuitry located in the inverter rack.

Power supply inhibit circuits are provided by U22 and relay K3. System Fault control and indication is provided by U19, U20 and U21, and associated circuitry. Diagnostic signals are latched and then sent to the FRONT PANEL ASSEMBLY for status indication.

4.7 Front Panel Assembly

Front Panel controls, meters and status indications are connected to the FRONT PANEL PWB. The FRONT PANEL PWB interfaces directly to the CONTROL/POWER PWB via the use of a mass terminated ribbon connector.

4.8 Options

Due to the many variations of models and options provided in the SLS Series, details of actual circuits used may differ slightly from the above descriptions. Consult Spellman's Sales Department for questions regarding the principles of operation for the SLS Series.

Chapter 5

OPTIONS

The options available for this power supply are described in this section. Interface diagrams are shown where required. Options are specified by including the option code in the model number as described in Section 1.3.

5.1 Adjustable Overload Trip --AOL

The overload trip protection feature rapidly shuts down the high voltage output when the current exceeds the limit set by the current control dial on the front panel (or remote programming signal, if used). A fast acting circuit inhibits the generation of high voltage and reverts the unit to POWER DOWN mode, illuminating the red OVER CURRENT fault indicator. When adjustable overload trip is provided, it replaces the standard current regulation feature.

5.2 200Vac Single Phase Input--200

SLS Series power supplies with the 200Vac input option will operate from an input voltage of 200Vac $\pm 10\%$, 50/60Hz, single phase.

5.3 No Slow Start--NSS

The no slow start option causes the output voltage of the power supply to rise (typically within 50 mS) to the rated voltage upon depressing the red HIGH VOLTAGE ON switch.

5.4 Non-Standard Slow Start--SS(x)

The non-standard slow start option allows the gradual rise time of the output voltage to be different from the standard of six seconds. To order the option place the time desired in seconds after the suffix letter, i.e. SS (10) denotes a 10 second rise time.

5.5 Arc Trip Option--AT

When this option is ordered, the Arc Count circuit is set so the unit trips to POWER DOWN after 1 arc, displaying an arc fault. One of the applications for this option is for sensing a material breakdown under an applied high voltage.

5.6 Instant On--IO

When the Instant On Option is ordered, the High Voltage is enabled as soon as line voltage is applied when the circuit breaker is in the ON position. (See Figure 5.7)

To enable Instant On, keep the jumper between J3-14 and J3-15 attached. Connect an additional jumper from J3-15 to J31-16 as shown in Figure 5.7.

CAUTION

The Power Supply will generate programmed High Voltage whenever the circuit breaker is in the ON position, and line voltage is applied.

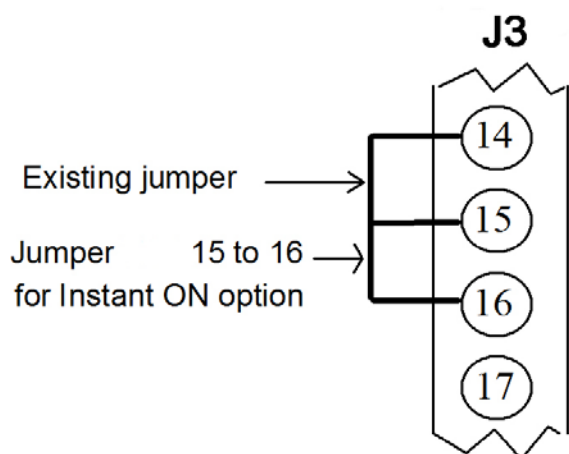

Figure 5.6 -- Instant ON

5.7 External Fault Relay Option-- EFR

The external fault relay option provides a set of customer accessible relay contacts that are controlled by the fault status circuitry of the applicable SLS Series power supply. A standard SLS power supply will revert to the “power down” mode with a visual front panel indication if any of the following fault conditions occur:

- **Overvoltage:** Greater than 110% of maximum output voltage was produced by the power supply.
- **Overcurrent:** Greater than 104% of maximum output current was produced by the power supply or the AOL circuitry was activated.
- **Overtemperature:** Excessive temperature has been sensed within the chassis.

- **Regulation Error:** Lack of required output power to maintain regulation
- **Arc (Shutdown):** Arc sensing circuit has shut down the supply due to excessive arcing.
- **Overpower:** The power supply has exceeded the internally set power limit level, if such circuitry is installed.

With the installation of the EFR option if any of these faults occur, a relay will be activated to provide a remote indication that the power supply has reverted to the “Power Down” mode. The common and normally open contacts are provided. Relay contacts are rated at 1A at 30Vdc or 0.5A at 48Vac.

Connections on the rear panel interface 25 pin D connector can be made as follows:

J3-12	Relay Common
J3-13	Normally Open

Resetting the front panel latched fault indicator and EFR relay is accomplished by depressing the green front panel HV OFF switch, which reverts the power supply back to the “standby” mode. Removal and reapplication of the AC line input voltage will also reset any fault.

The circuitry and components required for the EFR option are installed at the factory when this option is ordered.

5.8 Custom Designed Models-X#

Units built to customer specification are assigned an X number by the factory. If this unit is an X model, a specification control sheet is added at the end of this instruction manual.

Spellman welcomes the opportunity to customize units to fit your requirements or to develop new products for your applications. Contact the Spellman Sales Department with your needs at sales@spellmanhv.com

Chapter 6

MAINTENANCE

This section describes periodic servicing and performance testing procedures.

WARNING

THIS POWER SUPPLY GENERATES VOLTAGES THAT ARE DANGEROUS AND MAY BE FATAL. OBSERVE EXTREME CAUTION WHEN WORKING WITH HIGH VOLTAGE.

6.1 Periodic Servicing

Approximately once a year (more often in high dust environments), disconnect the power to the unit, wait 5 minutes and remove the top cover. Use compressed air to blow dust out of the inside of the unit. Be sure that the fan is not obstructed and spins freely. The fan has sealed bearings and does not need lubrication. Be sure to replace the top cover before operating for proper cooling.

6.2 Performance Test

WARNING

HIGH VOLTAGE IS DANGEROUS.

ONLY QUALIFIED PERSONNEL SHOULD PERFORM THESE TESTS.

High voltage test procedures are described in Bulletin STP-783, [Standard Test Procedures for High Voltage Power Supplies](#). Copies can be obtained from the

Spellman website. Test equipment, including an oscilloscope, a high impedance voltmeter, and a high voltage divider such as the Spellman HVD-200 or HVD-400, is needed for performance tests. All test components must be rated for operating voltage.

6.3 High Voltage Dividers

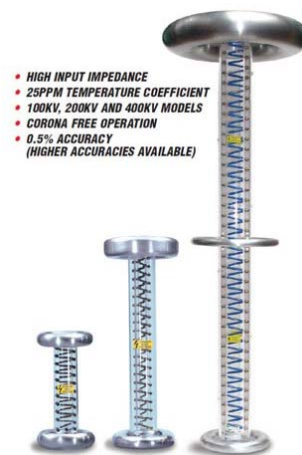

High voltage dividers for precise measurements of output voltage with accuracy up to 0.1% are available. An HVD-100 is used for voltages up to 100kV, HVD-200 measures up to 200kV and the HVD-400 measured up to 400kV. The Spellman HVD Series is designed for use with differential voltmeters or high impedance digital voltmeters. The high input impedance is ideal for measuring high voltage low current sources, which would be overloaded by traditional lower impedance dividers. The data sheet for Spellman's series of HVD dividers can be viewed by clicking [here](#).

Chapter 7

REPLACEMENT PARTS

7.1 Replacement Parts

Contact the Spellman Customer Service Department for parts lists for specific models.

Parts and subassemblies for Spellman's high voltage power supplies are available. It is recommended that only qualified personnel perform the repairs. High voltage is dangerous; even minor mistakes in repairs can have serious consequences.

When requesting parts, please provide the complete model number and serial number of the power supply in question.

7.2 Correspondence and Ordering Spare Parts

Each power supply has an identification label on the rear of the chassis that bears its model and serial number.

When requesting engineering or applications information, please state the model and serial number of the power supply. If specific components or circuit sections are involved in the inquiry, it is helpful to provide information clearly identifying the item in question.

When ordering spare parts, please specify the part number, the component function, and the model and serial number of the unit.

Chapter 8

FACTORY SERVICE

8.1 Warranty Repairs

During the Warranty period, Spellman will repair all units free of charge. The Warranty is void if the unit is worked on by other than Spellman personnel. See the Warranty in the rear of this manual for more information. Follow the return procedures described in Section 8.2. The customer shall pay for shipping to and from Spellman.

8.2 Factory Service Procedures

Spellman has a well-equipped factory repair department. If a unit is returned to the factory for calibration or repair, a detailed description of the specific problem should be attached.

For all units returned for repair, please obtain an authorization to ship from the Customer Service Department, either by phone or mail prior to shipping. When you call, please state the model and serial numbers, which are on the plate on the rear of the power supply, and the purchase order number for the repair. A Return Material Authorization Code Number (RMA Number) is needed for all returns. This RMA Number should be marked clearly on the outside of the shipping container. Packages received without an RMA Number will be returned to the customer. The Customer shall pay for shipping to and from Spellman.

A preliminary estimate for repairs will be given by phone by Customer Service. A purchase order for this amount is requested upon issuance of the RMA Number. A more detailed estimate will be made when the power supply is received at the Spellman Repair Center. In the event that repair work is extensive, Spellman will call to seek additional authorization from your company before completing the repairs.

8.3 Ordering Options and Modifications

Many of the options listed in Chapter 5 can be retrofitted into Spellman's power supplies by our factory. For prices and arrangements, contact the Spellman Sales Department.

8.4 Shipping Instructions

All power supplies returned to Spellman must be sent shipping prepaid. Pack the units carefully and securely in a suitable container, preferably in the original container, if available. The power supply should be surrounded by at least four inches of shock absorbing material. Please return all associated materials, i.e. high voltage output cables, interconnection cables, etc., so that we can examine and test the entire system.

All correspondence and phone calls should be directed to:

Spellman High Voltage Electronics Corp.
475 Wireless Boulevard
Hauppauge, New York 11788
TEL: (631) 630-3000 FAX: (631) 435-1620
E-Mail: sales@spellmanhv.com

To obtain information on Spellman's product warranty please visit our website at:

<http://www.spellmanhv.com/en/About/Warranty.aspx>

