

# Instruction Manual

## SA SERIES

### High Voltage Power Supply

MODEL :       XXXXX  
SERIAL# :     XXXXX  
DATE :        XXXXX

**SPELLMAN  
HIGH VOLTAGE ELECTRONICS  
CORPORATION**

475 Wireless Blvd.  
Hauppauge, New York, 11788

+1(631) 630-3000\*FAX: +1(631) 435-1620\*

E-mail: [sales@spellmanhv.com](mailto:sales@spellmanhv.com)

Website: [www.spellmanhv.com](http://www.spellmanhv.com)



- **COMPACT DESIGN AND LIGHTWEIGHT**
- **LOW COST PER WATT**
- **LOW EMI AND RFI**
- **CONSTANT VOLTAGE/CONSTANT CURRENT OPERATION WITH AUTOMATIC CROSSOVER**
- **ARC DETECT, ARC QUENCH AND ARC COUNT**
- **SYSTEM STATUS INDICATORS**
- **OEM CUSTOMIZATION AVAILABLE**

[www.spellmanhv.com/manuals/SA](http://www.spellmanhv.com/manuals/SA)

SA power supplies are available in 13 models with voltage outputs ranging from 1kV to 70kV. Similar to the SR power supplies, they incorporate series resonant inverter technology with a patented control circuit. This enables the supplies to operate without damage or interruption in rugged environments that frequently pose threats to conventional high voltage power supplies. In addition, the SA Series protect your load from excessive peak current when an arcover condition is sensed. Parallel operation options to increase power and current capabilities are available for SA models with power outputs of 8kW, 12kW and higher.

### TYPICAL APPLICATIONS

Sputtering	CW Lasers
Analytical X-ray	Ion Implantation
Electron Beam Systems	Capacitor Charging
Radar Modulators	

### OPTIONS

<b>200-1P</b>	200Vac Single Phase Input
<b>200-3P</b>	200Vac Three Phase Input
<b>220-1P</b>	220Vac Single Phase Input
<b>AOL</b>	Adjustable Overload Trip
<b>FG</b>	Floating Ground
<b>CPC</b>	Constant Power Control
<b>APT</b>	Adjustable Power Trip
<b>RMI</b>	Remote Mode Indicators
<b>ROA</b>	Remote Overvoltage Adjust
<b>NSS</b>	No Slow Start
<b>SS(x)</b>	Nonstandard Slow Start
<b>SL</b>	Mounting Slides
<b>BFP</b>	Blank Front Panel

### SPECIFICATIONS

#### Input:

208Vac $\pm$ 10%, 50 or 60Hz, three phase.

#### Output:

13 models from 1kV to 70kV. Each model is available with positive, negative or reversible polarity outputs.

#### Output Controls:

Voltage and current are continuously adjustable over entire range via ten-turn potentiometers with lockable counting dials.

#### Voltage Regulation:

Load: 0.005% of full voltage +500mV for full load change.  
Line:  $\pm$ 0.005% of full voltage +500mV over specified input range.

#### Current Regulation:

Load: 0.05% of full current  $\pm$ 100 $\mu$ A for any voltage change.  
Line:  $\pm$ 0.05% of full current over specified input range.

#### Ripple:

0.1% +1Vrms for three phase models only.  
0.3% +1Vrms for single phase models only.

#### Temperature Coefficient:

100ppm/ $^{\circ}$ C. Higher Stability (50ppm/ $^{\circ}$ C) available on special order.

#### Stability:

0.01%/hr. after 1/2 hour warm-up, 0.02% per 8 hrs. (typical).

#### Metering:

Digital voltage and current meters, 1% accuracy.

#### System Status Display:

"Dead Front" type indicators provide status of up to 14 system operations including voltage and current regulation, fault conditions and circuit control.

#### Output Cable:

10 ft. (3.05m) shielded high voltage cable, removable at rear panel.

#### Dimensions:

5 $\frac{1}{4}$ "H (3U) x 19"W x 22"D rack mount.  
(13.3cm x 48.3cm x 55.9cm)

#### Regulatory Approvals:

Compliant to 2004/108/EC, the EMC Directive and 2006/95/EC, the Low Voltage Directive.

#### SA SELECTION TABLE

MAXIMUM RATING		MODEL NUMBER
kV	mA	
1	4000	SA1PN4
2	2000	SA2PN4
3	1330	SA3PN4
4	1000	SA4PN4
6	667	SA6PN4
10	400	SA10*4
15	267	SA15*4
20	200	SA20*4
30	133	SA30*4
40	100	SA40*4
50	80	SA50*4
60	67	SA60*4
70	57	SA70*4

\*Specify "P" for positive, "N" for negative, or "PN" for reversible polarity. Higher voltage or intermediate voltage models available on special order. From 1kV to 6kV, reversible polarity is accomplished by an internal wiring change. From 10kV to 70kV, polarity is reversed by exchanging internal high voltage assemblies.

#### SA TERMINAL BLOCK 18 PIN

TB1	SIGNAL
1	P.S. Common
2	Inhibit
3	External Interlock In
4	External Interlock Out
5	mA Test point Out
6	kV Test point Out
7	+10Vdc Reference
8	mA Program In
9	Local mA Program Out
10	kV Program In
11	Local kV Program Out
12	Remote Pwr On In
13	Remote Pwr On Out
14	Remote HV Off
15	Remote HV Off/On Common
16	Remote HV On
17	HV Off Indicator
18	HV On Indicator

DIMENSIONS: in.[mm]

#### FRONT VIEW

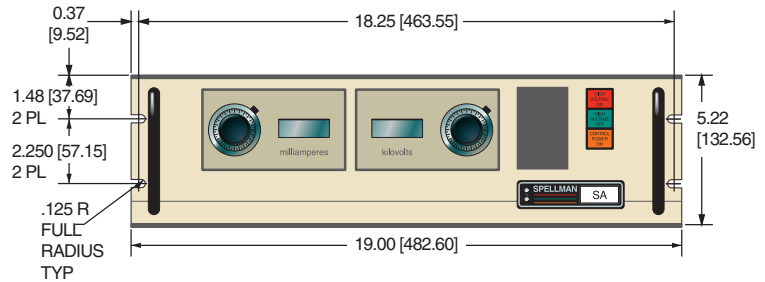

#### TOP VIEW

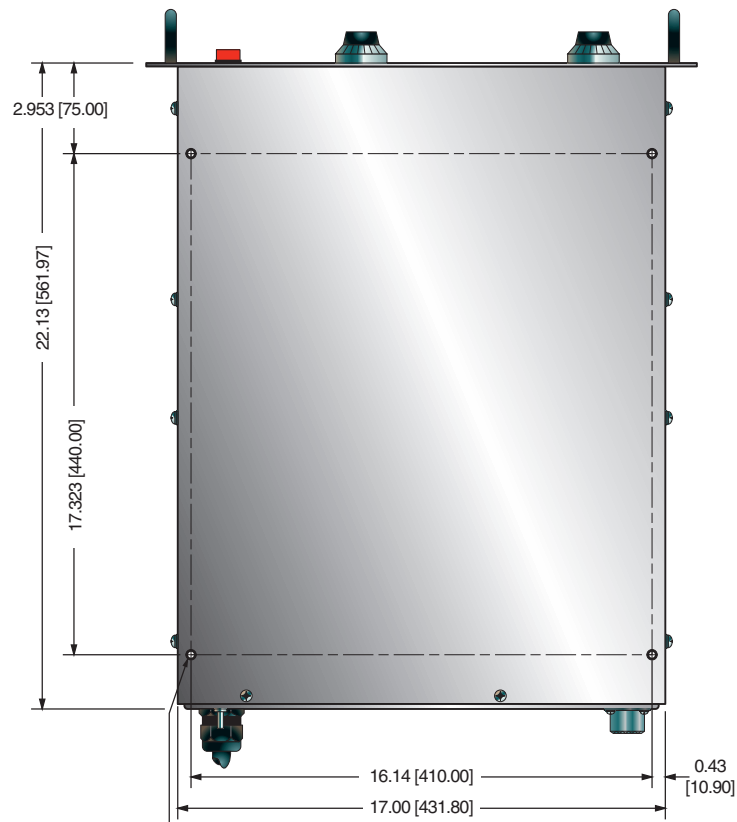

M5X0.8-7mm DEEP THREADED  
INSERT TYPICAL 8 PLACES

#### BACK VIEW

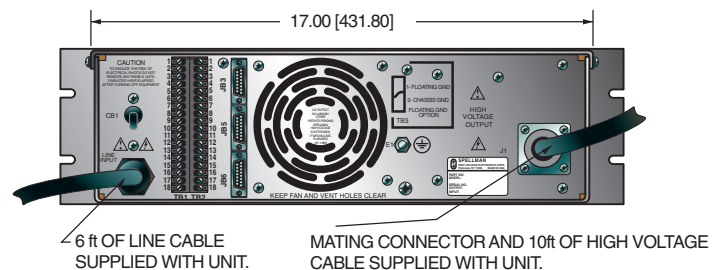

## IMPORTANT SAFETY PRECAUTIONS

### SAFETY

THIS POWER SUPPLY GENERATES VOLTAGES THAT ARE DANGEROUS AND MAY BE FATAL.  
OBSERVE EXTREME CAUTION WHEN WORKING WITH THIS EQUIPMENT.

High voltage power supplies must always be grounded.

Do not touch connections unless the equipment is off and the Capacitance of both the load and power supply is discharged.

Allow five minutes for discharge of internal capacitance of the power supply.

Do not ground yourself or work under wet or damp conditions.

### SERVICING SAFETY

Maintenance may require removing the instrument cover with the power on.

Servicing should be done by qualified personnel aware of the electrical hazards.

**WARNING** note in the text call attention to hazards in operation of these units that could lead to possible injury or death.

**CAUTION** notes in the text indicate procedures to be followed to avoid possible damage to equipment.

Copyright © 2000, Spellman High Voltage Electronics Corporation. All Rights Reserved.  
This information contained in this publication is derived in part from proprietary and patent data. This information has been prepared for the express purpose of assisting operating and maintenance personnel in the efficient use of the model described herein, and publication of this information does not convey any right to reproduce it or to use it for any purpose other than in connection with installation, operation, and maintenance of the equipment described.

# WICHTIGE SICHERHEITSHINWEISE

## SICHERHEIT

DIESES HOCHSPANNUNGSNETZTEIL ERZEUGT LEBENSGEFÄHRLICHE HOCHSPANNUNG.  
SEIN SIE SEHR VORSICHTIG BEI DER ARBEIT MIT DIESEM GERÄT.

Das Hochspannungsnetzteil muß immer geerdet sein.

Berühren Sie die Stecker des Netzteiles nur, wenn das Gerät ausgeschaltet ist und die elektrischen Kapazitäten des Netzteiles und der angeschlossenen Last entladen sind.

Die internen Kapazitäten des Hochspannungsnetzteiles benötigen ca. 5 Minuten, um sich zu entladen.

Erden Sie sich nicht, und arbeiten Sie nicht in feuchter oder nasser Umgebung.

## SERVICESICHERHEIT

Notwendige Reparaturen können es erforderlich machen, den Gehäusedeckel während des Betriebes zu entfernen.

Reparaturen dürfen nur von qualifiziertem, eingewiesenem Personal ausgeführt werden.

“WARNING” im folgenden Text weist auf gefährliche Operationen hin, die zu Verletzungen oder zum Tod führen können.

“CAUTION” im folgenden Text weist auf Prozeduren hin, die genauestens befolgt werden müssen, um eventuelle Beschädigungen des Gerätes zu vermeiden.

# PRECAUTIONS IMPORTANTES POUR VOTRE SECURITE

## CONSIGNES DE SÉCURITÉ

CETTE ALIMENTATION GÉNÈRE DES TENSIONS QUI SONT DANGEUREUSES ET PEUVENT ÊTRE FATALES.  
SOYEZ EXTRÊMEMENT VIGILANTS LORSQUE VOUS UTILISEZ CET ÉQUIPEMENT.

Les alimentations haute tension doivent toujours être mises à la masse.

Ne touchez pas les connectiques sans que l'équipement soit éteint et que la capacité à la fois de la charge et de l'alimentation soient déchargées.

Prévoyez 5 minutes pour la décharge de la capacité interne de l'alimentation.

Ne vous mettez pas à la masse, ou ne travaillez pas sous conditions mouillées ou humides.

## CONSIGNES DE SÉCURITÉ EN CAS DE REPARATION

La maintenance peut nécessiter l'enlèvement du couvercle lorsque l'alimentation est encore allumée.

Les réparations doivent être effectuées par une personne qualifiée et connaissant les risques électriques.

Dans le manuel, les notes marquées « **WARNING** » attire l'attention sur les risques lors de la manipulation de ces équipements, qui peuvent entraîner de possibles blessures voire la mort.

Dans le manuel, les notes marquées « **CAUTION** » indiquent les procédures qui doivent être suivies afin d'éviter d'éventuels dommages sur l'équipement.

## IMPORTANTI PRECAUZIONI DI SICUREZZA

### SICUREZZA

QUESTO ALIMENTATORE GENERA TENSIONI CHE SONO PERICOLOSE E POTREBBERO ESSERE MORTALI.  
PONI ESTREMA CAUTELA QUANDO OPERI CON QUESTO APPARECCHIO.

- Gli alimentatori ad alta tensione devono sempre essere collegati ad un impianto di terra.
- Non toccare le connessioni a meno che l'apparecchio sia stato spento e la capacità interna del carico e dell'alimentatore stesso siano scariche.
- Attendere cinque minuti per permettere la scarica della capacità interna dell'alimentatore ad alta tensione.
- Non mettere a terra il proprio corpo oppure operare in ambienti bagnati o saturi d'umidità.

### SICUREZZA NELLA MANUTENZIONE.

- Manutenzione potrebbe essere richiesta, rimuovendo la copertura con apparecchio acceso.
- La manutenzione deve essere svolta da personale qualificato, coscio dei rischi elettrici.
- Attenzione alle **AVVERTENZE** contenute nel manuale, che richiamano all'attenzione ai rischi quando si opera con tali unità e che potrebbero causare possibili ferite o morte.
- Le note di **CAUTELA** contenute nel manuale, indicano le procedure da seguire per evitare possibili danni all'apparecchio.

# Table of Contents

PAGE

## 1. INTRODUCTION

1.1	Description of the SA Series.....	1
1.2	SA Specifications.....	1
1.3	Standard Features.....	1
1.3.1	Remote Operating Features.....	2
1.3.2	System Status and Fault Diagnostic Display.....	2
1.4	Options.....	3
1.5	Interpreting the Model Number.....	3

## 2. INSPECTION & INSTALLATION

2.1	Initial Inspection.....	4
2.2	Mechanical Installation.....	4

## 3. OPERATING INSTRUCTIONS

3.1	Operation.....	6
3.2	Standard Features.....	7

## 4. PRINCIPLES OF OPERATION

4.1	Chassis.....	13
4.2	Line Rectifier and Filtering.....	13
4.3	Inverter.....	14
4.4	High Voltage Transformer.....	15
4.5	High Voltage Assembly.....	15
4.6	System Control PWB.....	15
4.7	Front Panel Assembly.....	16
4.8	Rear Panel Interface PWB.....	16
4.9	Options.....	16

## 5. OPTIONS

5.1	Adjusting Overload Trip.....	17
5.2	220C AC Single Phase Input.....	17
5.3	No Slow Start.....	17
5.4	Non-Standard Slow Start.....	17
5.5	Extra Length Output Cable.....	17
5.6	Slides.....	17
5.7	Remote Over Voltage Adjust.....	17
5.8	Remote Mode Indicators.....	17
5.9	Floating Ground.....	17
5.10	Adjustable Power Trip/Constant Power Control.....	19
5.11	Custom Designed Models.....	19
5.12	Parallel Option (8KW).....	20
5.13	Parallel Option (12KW).....	22
5.14	Polarity Reversal.....	24

<b>6. MAINTENANCE</b>	
6.1	Periodic Servicing.....26
6.2	Performance Test.....26
6.3	High Voltage Dividers.....26
<b>7. REPLACEMENT PARTS</b>	
7.1	Replacement Parts.....27
7.2	Correspondence and Ordering Spare Parts.....27
<b>8. FACTORY SERVICE</b>	
8.1	Warranty Repairs.....28
8.2	Factory Service Procedures.....28
8.3	Ordering Options and Modifications.....28
8.4	Shipping Instructions.....28

## APPENDIX

A.	Specification Controls (Custom Models Only)
----	---

## LIST OF FIGURES

Figure 2.1	Dimensions.....5
Figure 3.1	Typical Operating Setup.....8
Figure 3.2A	Remote Programming via Voltage Source.....9
Figure 3.2B	Remote Programming via External Resistance.....9
Figure 3.3	Remote Monitor Test Point Designations.....10
Figure 3.4	Remote Control Power On, HV ON and HV OFF.....10
Figure 3.5	External Inhibit Interface Circuit.....11
Figure 3.6	External Interlock Interface Circuit.....11
Figure 3.7	Remote HV ON and Remote HV OFF Indicator Circuit.....12
Figure 5.1	Remote Overvoltage Adjust Interface.....18
Figure 5.2	Remote Mode Indicators Interface.....18
Figure 5.3	Floating Ground Interface Circuit.....19
Figure 5.4	Adjustable Power Remote Interface.....20
Figure 5.5	8kW Installation Drawing.....21
Figure 5.6	12kW Installation Drawing.....23
Figure 5.7	Polarity Reversal, 1-6 kV and Multiplier Location 10-70kV.....25

## LIST OF TABLES

Table 1.1	Options.....3
Table 4.1	List of Main Assemblies.....14
Table 5.1	Polarity Selection Table 1-6 kV.....25

# Chapter 1

## INTRODUCTION

### 1.1 Description of the SA Series

The SA series of high voltage power supplies provides very well regulated, low ripple high voltage in a highly efficient, compact design. The improvements in size and performance over traditionally designed high voltage power supplies are due to the series resonant topology and unique control circuitry of the SA design. The currents in the power circuits are sinusoidal, starting and stopping at zero. This zero current switching eliminates undesirable electromagnetic radiation and minimizes switching losses normally associated with switching regulators. A patented control system maintains a constant frequency over the operating output range. Constant frequency operation allows a dynamic response time of less than 5 milliseconds, and one of the lowest ripple specifications in the industry at this power level. The combination of the patented control system and proprietary protection circuitry enables the supplies to operate under arcing and extreme transient conditions without damage or interruptions.

The DC output voltage and current are continuously adjustable from zero to the maximum rating via two front panel ten turn locking potentiometers. These high voltage power supplies have 0.005% load regulation, 0.005% line regulation, and 0.1% rms ripple.

The supplies operate from a 208 Volt three phase AC line and are fan cooled. Other line voltages are available. Options are listed in Table 1.1 and described in Section 5. Custom designed units to meet special needs are also available.

The standard warranty applies to standard SA units. Consult factory about the warranty for custom SA units.

### 1.2 SA Specifications

- **Output Control:** Voltage and current are continuously adjustable over the entire range from zero to maximum rating via a ten-turn potentiometer with a lockable counting dial.
- **Input Voltage:** 208 Volts AC  $\pm 10\%$ , 50/60Hz, three phase. Other input voltages are available on request.
- **Voltage Regulation:**  
**Load Regulation:** 0.005% of full voltage +500mV for a no load to full load change.

**Line Regulation:**  $\pm 0.005\%$  of full voltage +500mV over the specified input voltage range.

- **Current Regulation:**  
**Load Regulation:**  $\pm 0.05\%$  of full current  $\pm 100\mu\text{A}$  for any voltage change.  
**Line Regulation:**  $\pm 0.05\%$  of full current over the specified input voltage range.
- **Ripple:**  
0.1% rms +1V<sub>rms</sub> of rated output voltage for three phase input models.  
0.3% rms +1V<sub>rms</sub> of rated output voltage for single phase input models.
- **Polarity:** Positive, Negative, and Reversible polarity with respect to ground are available.
- **Stability:** 0.01% per hour after 1/2 hour warm up. 0.02% per 8 hours (typical).
- **Temperature Coefficient:** 100 ppm per °C. Higher stability (50 ppm per °C) available on special order.
- **Ambient Temperature:**  
Operating: -20°C to +40°C  
Storage: -40°C to +85°C
- **Metering:** Digital voltage and current meters are accurate to 1%.
- **Weight:** 40-70 lbs. (typical)
- **Physical:**  
5 ¼”H x 19”W x 22”D rack mount for units 1kV to 70kV.

### 1.3 Standard Features

The SA series incorporates several standard features designed to optimize user satisfaction and safety.

**SLOW START:** This feature provides a gradual increase in high voltage until the preset operating point is reached. The slow start time is factory set for 6 seconds. Other slow start times are available as an option.

**ARC DETECT / ARC QUENCH / ARC COUNT:**

These features allow the user to tailor the power supply to meet specific needs in dynamic load applications. If an arc occurs, the output is inhibited for approximately one second, then the output is ramped up to the preset level with the slow-start circuitry. See Chapter 3 for operating details and information for user customization for these features.

**INTERNAL FAULT PROTECTION:** The SA series continually monitors internal circuits critical to the proper operation of the power supply. In the event that one of these circuits does not function correctly, the fault detection circuit turns off the output and reverts the unit to the POWER DOWN mode.

**INDICATOR LAMPS:** CONTROL POWER ON, HIGH VOLTAGE OFF and HIGH VOLTAGE ON indicators are equipped with dual lamps for safety.

**OUTPUT CABLE:** All models are provided with a ten foot shielded high voltage output cable. The cables are designed with a plug arrangement so that they can be easily removed from the mating receptacle located on the rear of the chassis.

### 1.3.1 Remote Operating Features

**REMOTE PROGRAMMING:** Allows remote adjustment of the output voltage and current via an external voltage source. The output power is also remotely controllable when the CPC or APT option is ordered.

**REMOTE MONITOR:** Allows remote monitoring of the output voltage and current. NOTE: Output power remote monitor is included with the CPC and APT options.

**REMOTE HIGH VOLTAGE CONTROL:** Allows remote control of the HIGH VOLTAGE ON and HIGH VOLTAGE OFF functions. Signals are also provided for remote indication of ON or OFF status.

**REMOTE POWER ON:** Allows remote control of CONTROL POWER ON/OFF functions. This feature also allows remote reset of the power supply in case of SYSTEM FAULT shutdown.

**REMOTE POWER ON STATUS:** This signal indicates the status of the POWER ON control. This signal also provides indication of a SYSTEM FAULT shutdown (optional).

**EXTERNAL INHIBIT:** A circuit that will inhibit the high voltage output is provided on the terminal block TB1 on the rear of the chassis. A logic low, ground, will inhibit the high voltage output and a logic high, open, will

restore the high voltage output to the preset level.

NOTE: The External Inhibit circuit should NOT be used for protection against injury or for safety interlock. See External Interlock for this type of safety control

**EXTERNAL INTERLOCK:** Interlock connections are provided on the terminal block on the rear of the chassis for connection to a safety switch. The unit will not operate unless the interlock circuit is closed. During high voltage operation, opening the interlock circuit will cause the High Voltage to shut off. This circuit should be used for safety interlock circuits.

### 1.3.2 System Status and Fault Diagnostic Display

“Dead Front” type indicators are provided to give the user complete indication of system operation and fault conditions. If a fault occurs the power supply will revert to the POWER DOWN mode. This is indicated by a flashing of the CONTROL POWER ON indicator. To reset, depress the CONTROL POWER ON switch.

**VOLTAGE CONTROL:** Indicates the output voltage regulator circuit is maintaining voltage regulation.

**CURRENT CONTROL:** Indicates the output current regulator circuit is maintaining current regulation.

**POWER CONTROL:** Indicates the output power regulator circuit is maintaining power regulation (optional).

**HV INHIBIT:** Indicates the high voltage supply is being inhibited by either the EXTERNAL INHIBIT or internal protection circuitry.

**INTLK CLSD:** Indicates the EXTERNAL INTERLOCK connections are in the closed position. This also indicates closure of internal power supply interlocks.

**INTLK OPEN:** Indicates the EXTERNAL INTERLOCK connections are in the open position. This also indicates opening of internal power supply interlocks.

**SYSTEM FAULT:** Indicates an internal fault, status indicator fault or parallel/filament fault has occurred.

**OVER VOLTAGE:** Indicates the overvoltage protection circuitry has caused the power supply to turn off. Overvoltage protection is internally set to 105% of rated output voltage or by the remote overvoltage adjust option.

**OVER CURRENT:** Indicates the output current has exceeded the programmed current trip level when the AOL (Adjustable Overload Trip) or the OL (overload Trip) options are installed.

**OVER POWER:** Indicates the output power has exceeded the internally set level or the remote programmed level if the optional circuitry is installed.

**ARC:** Indicates that an arc has occurred within the previous one second or that the ARC COUNT/TRIP has shutdown the power supply.

**RGLT ERROR:** Indicates a failure in the voltage, current or power regulation circuitry. This fault usually occurs when there is a lack of output power to maintain regulation.

**INV FAULT:** Indicates a cross-conduction in the inverter has occurred within the previous one second or the inverter diagnostic circuitry has indicated a complete inverter failure causing a shutdown of the power supply.

**OVER TEMP:** Indicates an excessive temperature has been sensed within the chassis and protection circuitry has shutdown the power supply. This may be caused by a fan failure or by inadequate ventilation.

## 1.4 Options

CODE DISCRIPTION	
• <b>AOL</b>	Adjustable Overload Trip (0-103%)
• <b>ROA</b>	Remote Overvoltage Adjust
• <b>RMI</b>	Remote Mode Indicators
• <b>FG</b>	Floating Ground
• <b>CPC</b>	Constant Power Control
• <b>LR</b>	Low Ripple (0.05% rms)
• <b>220</b>	220V AC Single Phase Input
• <b>APT</b>	Adjustable Power Trip
• <b>NSS</b>	No Slow Start
• <b>SS(X)</b>	Non-Standard Slow Start
• <b>SL</b>	Slides
• <b>LL(X)</b>	Extra Length Output Cable
•	Reduced Stored Energy
•	Filament Power Supply
•	8kW, 12kW Parallel Operation

**Table 1.1 SA Options**

The options available are listed in Table 1.1. See Section 5 for more information on these options along with operating and set-up instructions. With few exceptions, these options and modifications can be retrofitted to your power supply at the factory in a short time. For price and retrofit arrangements, contact Spellman's Sales Department.

## 1.5 Interpreting the Model Number:

The model number of the power supply describes its capabilities. After the series name is:

- (1) the maximum voltage (in kV)
- (2) the polarity of the unit – positive (P), negative (N), or reversible (PN)
- (3) the maximum output (in kilowatts)

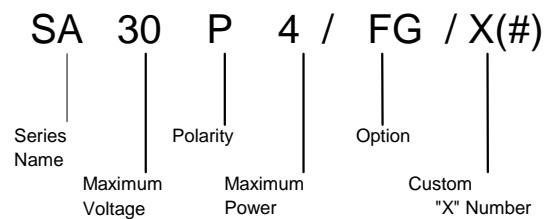

- (4) the option codes for all options that are included.
- Custom units have an X number after the option codes.

# Chapter 2

## Inspection and Installation

**I**nitial inspection and preliminary checkout procedures are recommended. For safe operation, please follow the step-by-step procedures described in Chapter 3, Operating Instructions.

### 2.1 Initial Inspection

Inspect the package exterior for evidence of damage due to handling in transit. Notify the carrier and Spellman immediately if damage is evident. Do not destroy or remove any of the packing material used in a damaged shipment.

After unpacking, inspect the panel and chassis for visible damage.

Fill out and mail the Warranty Registration card accompanying the unit. Standard Spellman SA

high voltage power supplies and components are covered by warranty. Custom and special order models (with an X suffix in the model number) are also covered by warranty.

### 2.2 Mechanical Installation

Units in the SA series have front panel holes for standard EIA rack mounting. The rack must allow rear access for cable connections. Units are fully enclosed and are suitable for bench or tabletop operation. Standard unit dimensions are shown in Figure 2.1. It is strongly recommended to support the chassis by guides or slides. Slides are available for ease of servicing (SL option).

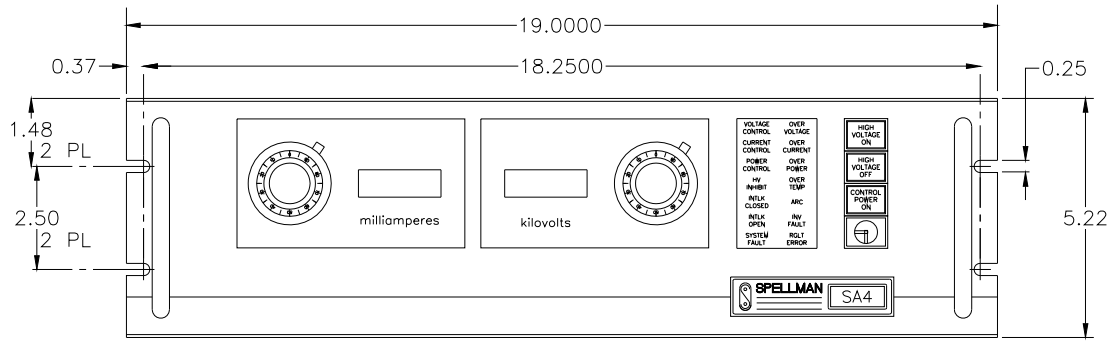

FRONT PANEL

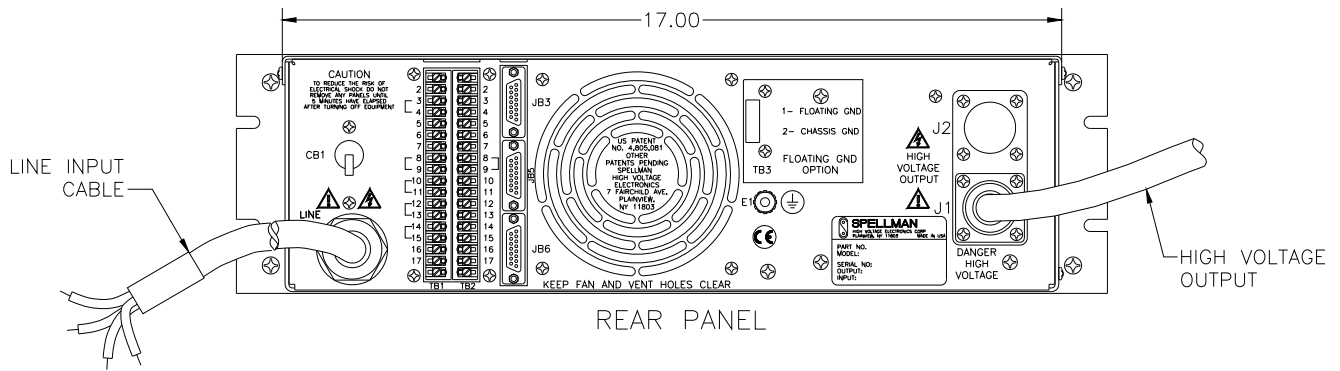
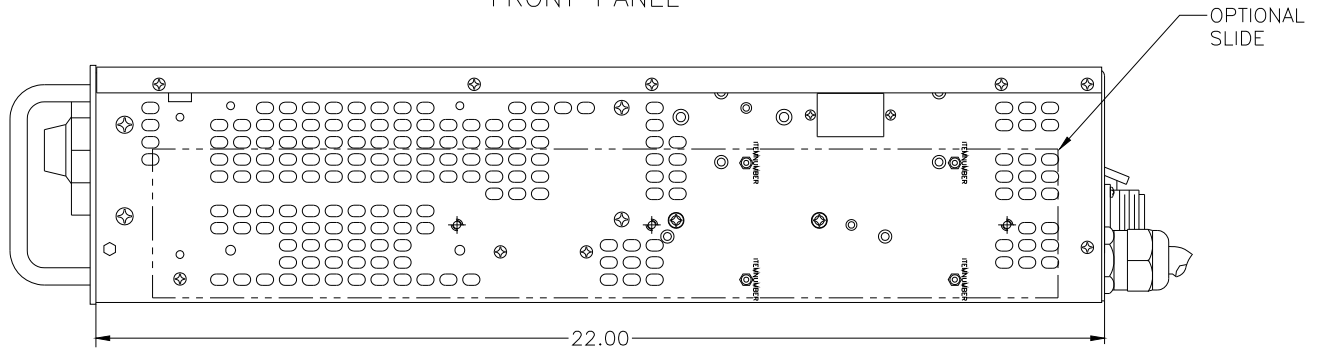

REAR PANEL

**Figure 2.1 DIMENSIONS**

# Chapter 3

## Operating Instructions

### 3.1 Operation

#### WARNING

**THIS EQUIPMENT GENERATES DANGEROUS VOLTAGES THAT MAY BE FATAL. PROPER GROUNDING OF ALL HIGH VOLTAGE EQUIPMENT IS ESSENTIAL.**

#### WARNING:

**BEFORE CONNECTING THE POWER SUPPLY TO THE AC LINE, FOLLOW THIS STEP-BY-STEP PROCEDURE. DO NOT CONNECT THE POWER SUPPLY TO THE AC LINE UNTIL STEP 'H' IS REACHED. FAILURE TO FOLLOW THESE PROCEDURES MAY VOID THE WARRANTY.**

- A) Insure that the CONTROL POWER ON switch is in the OFF position (switch bezel out).
- B) Check the input voltage rating on the nameplate of the supply and make certain that this is the rating of the available power source. Spellman SA units operate on 208V AC three phase unless ordered with a different input voltage.
- C) **PROPER GROUNDING TECHNIQUE:** The chassis of high voltage power supplies must be grounded, preferably to a water system ground using copper pipe or other earth ground using the connection terminal at the rear of the unit.. See Figure 3.1 for a typical operating setup.

The return line from the load should be connected to the ground stud (E1) on the rear of the power supply. Using a separate external ground at the load is not recommended.

A four-wire cable is provided for connecting to the AC supply. The BROWN, BLACK and BLUE wires are the three phase input. The GREEN/YELLOW wire is for chassis safety ground connection.

- D) Attach the output cable to the load.
- E) Plug the high-voltage output cable provided with the unit into the rear of the supply and hand-tighten the knurled collar.
- F) **Options Note:** See section 5 for hook up and operating instructions for the options on your unit. Custom models may also require set up changes.
- G) For initial turn-on, rotate the KILOVOLT control fully counter-clockwise to the zero voltage position.
- H) The input power cable may now be connected to the AC power line.
- I) Switch the rear panel circuit breaker to the ON position. The circuit breaker provides overload protection only, and can be kept on for normal operation. If the supply is to be turned off for an extended period of time, the line cord should be disconnected. Depress the CONTROL POWER ON switch. The light inside the switch should light up. The unit is now in the HIGH VOLTAGE OFF mode. The HIGH VOLTAGE OFF light should be lit.
- J) Depress and hold the HIGH VOLTAGE OFF switch. The front panel meters will now read the preset value of the KILOVOLT control dial and the MILLAMPERES control dial. To preset the desired level of the current and voltage during operation, hold in the HIGH VOLTAGE OFF switch and rotate the appropriate control dial while noting its corresponding meter reading. Release the HIGH VOLTAGE OFF switch.

NOTE: No actual output is being produced at this stage.

- K) Depress the HIGH VOLTAGE ON switch. The light inside the switch should light up and the output will slow start to the preset level output voltage and/or output current.

**Note:** The SA series is equipped with a slow start circuit that ramps the output up to its maximum setting in approximately 6 seconds after the HIGH VOLTAGE ON switch is depressed.

L) To terminate the generation of output power, depress the HIGH VOLTAGE OFF switch. In the HIGH VOLTAGE OFF mode the power supply's fault and interface circuits are still active.

M) To turn off the power supply, depress the CONTROL POWER ON switch a second time to release the switch bezel out.

NOTE: If a power supply fault, or system monitoring fault occurs, the power supply will revert to the POWER DOWN mode. In this mode the output power will be turned off. The CONTROL POWER ON lamp will flash indicating a SYSTEM FAULT. To reset the SYSTEM FAULT toggle the CONTROL POWER ON switch.

### WARNING

**AFTER TURNOFF, DO NOT HANDLE THE LOAD UNTIL THE CAPACITANCE HAS BEEN DISCHARGED!  
LOAD CAPACITANCE MAY BE DISCHARGED BY SHORTING TO GROUND.**

### WARNING

**THE VOLTMETER ON THE POWER SUPPLY FRONT PANEL DOES NOT READ THE OUTPUT VOLTAGE WHEN THE POWER IS TURNED OFF, EVEN IF A CHARGE STILL EXISTS ON THE LOAD.**

### CAUTION

**ALWAYS OPERATE THE UNIT WITH THE COVER ON.**

A fan maintains safe operating temperature in the power supply by drawing air over the circuit components. The cover must be on in order to direct the air flow over the areas that need cooling. In operation, the unit must be placed so that the air intake and the fan exhaust are clear of any obstructions that might impede the flow of air.

## 3.2 Standard Features

A note on remote interface circuitry and remote signal grounding. Whenever possible, electrical isolation should be provided when interfacing with any high voltage power supply. For power control signals such as POWER ON/OFF, EXTERNAL INTERLOCK, HIGH VOLTAGE OFF and HIGH VOLTAGE ON isolated relay contacts should be used. For status signals and control signals

such as HIGH VOLTAGE ON, HIGH VOLTAGE OFF, EXTERNAL INHIBIT, etc. opto-isolation should be used. If possible, analog programming and monitoring signals should be isolated via analog isolation amplifiers. Spellman application engineers are available to assist in interface circuitry design. All interface cables should be properly shielded. All power supply signals should be referenced to the power supplies signal ground on the rear terminal block TB1-1.

**REMOTE PROGRAMMING:** Allows remote adjustment of the output voltage and current via an external voltage source. (Output power is also remotely controllable with the CPC and APT options). In local control (front panel control), jumpers are installed on the terminal block TB1 in the rear of the chassis between TB1-10 and TB1-11 for voltage control and between TB1-8 and TB1-9 for current control. (Jumpers are installed between TB2-8 and TB2-9 for power control).

For remote programming, the jumpers are removed and a positive voltage source, from 0 to 10 volts, is applied to the appropriate terminals. Programming signals should be referenced to TB1-1, signal ground. By adjusting the voltage source from 0 volts (zero output) to 10 volts (full rated output) the desired output can be selected. See Figure 3.2A for wiring diagram and specifications.

An alternate method of controlling the output remotely is by using external resistance such as a potentiometer or a resistor network. For remote control the jumpers are removed and the desired resistor configuration is installed. See Figure 3.2B for wiring diagram.

**REMOTE MONITOR:** Test points are made available on the rear of the chassis for monitoring the voltage and current output. (Output power monitor is included with the CPC and APT option). The test points are always positive regardless of the output polarity, where zero (0) to ten (10) volts equals 0-100% of output  $\pm 0.5\%$ . Test points have an output impedance of 1k ohms. See Figure 3.3 for test point designation.

**REMOTE CONTROL:** Remote control of the POWER ON, HIGH VOLTAGE ON and HIGH VOLTAGE OFF can be accomplished via the rear panel interface. The POWER ON control is an on-off toggle contact. HIGH VOLTAGE OFF and HIGH VOLTAGE ON are controlled by momentary normally closed and normally open contacts, respectively. See Figure 3.4 for recommended interface.

**EXTERNAL INHIBIT:** Allows the user to inhibit the power supply output without switching the HIGH VOLTAGE OFF control. This circuit can be used to generate fast slewing output waveforms or control high voltage generation as in Laser and Capacitor discharge applications. The maximum inhibit rate should not exceed 5Hz. Consult factory for higher repetition rates or high pulse load applications. See Figure 3.5 for the recommended interface circuit.

**WARNING**

**IT IS EXTREMELY DANGEROUS TO USE THIS CIRCUIT TO INHIBIT HIGH VOLTAGE GENERATION FOR THE PURPOSE OF SERVICING OR APPROACHING ANY AREA OF LOAD CONSIDERED UNSAFE DURING NORMAL USE**

**EXTERNAL INTERLOCK:** Interlock connections are provided on the terminal block TB1, terminals #3 and #4, on the rear of the chassis for connection to a safety switch. The unit will not operate unless the interlock circuit is closed. If the interlock is not being used, the jumper installed on the terminals before shipping *must* be in place. If the jumper is missing, or there is an open between the interlock terminals the unit's high voltage inverter will be disabled. During high voltage operation, opening the interlock circuit will cause the unit to revert to the HIGH VOLTAGE OFF mode. Subsequent closing of the interlock circuit will NOT return the unit to HIGH VOLTAGE ON mode, this must be accomplished by

depressing the HIGH VOLTAGE ON switch. See Figure 3.6 for the recommended interface circuit.

**ARC DETECT / ARC QUENCH / ARC COUNT:** The ARC DETECT circuit senses dynamic arcing or discharge conditions present at the output load. If an arc occurs, the output is inhibited for one second. After the one-second period, the output is ramped up to the previous set level. This ramp is based on the standard six-second slow start feature. The ARC DETECT ramp circuit may be disabled by removing CR22 on the System Control PWB. The ARC QUENCH circuit may be disabled by removing CR40 on the System Control PWB. Caution should be observed if these features are disabled. Discharge rates of greater than 1 Hz may cause excessive power dissipation in the power supply's output limiting resistors.

The ARC COUNT feature will allow the user to program the ARC fault parameters. The ARC indicator on the front panel will illuminate for approximately one second after each arc has occurred. The HV INHIBIT indicator will also illuminate for one second indicating that the output is being inhibited. The power supply can be programmed to trip to the POWER DOWN mode if an arc occurs. The standard feature is programmed to trip the power supply if 8 arcs occur within a twenty second period. Details for programming the ARC COUNT feature are provided on schematic 440371-001 at the end of this manual.

**REMOTE HIGH VOLTAGE ON & REMOTE HIGH VOLTAGE OFF:** Signals are provided for remote monitoring of the HIGH VOLTAGE ON/OFF status. See Figure 3.7 for recommended interface.

It is recommended to connect the load return directly to the E1 ground stud located on the rear of the high voltage power supply.

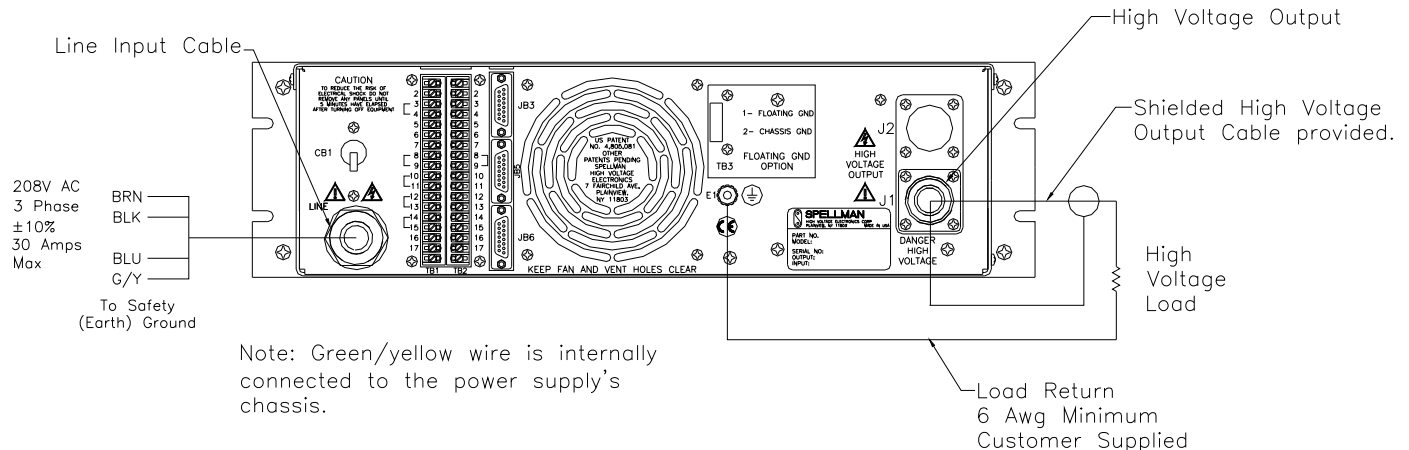
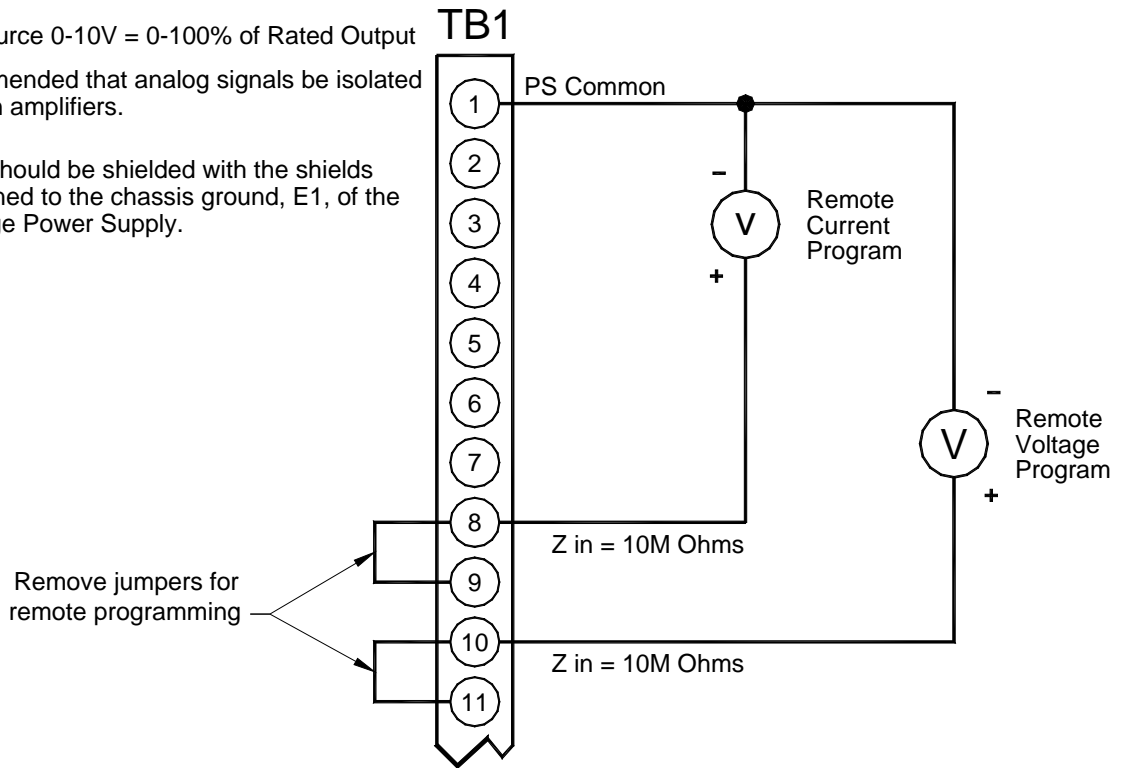

**Figure 3.1 Typical Operating Setup**

Voltage Source 0-10V = 0-100% of Rated Output

It is recommended that analog signals be isolated via isolation amplifiers.

All cables should be shielded with the shields being returned to the chassis ground, E1, of the High Voltage Power Supply.

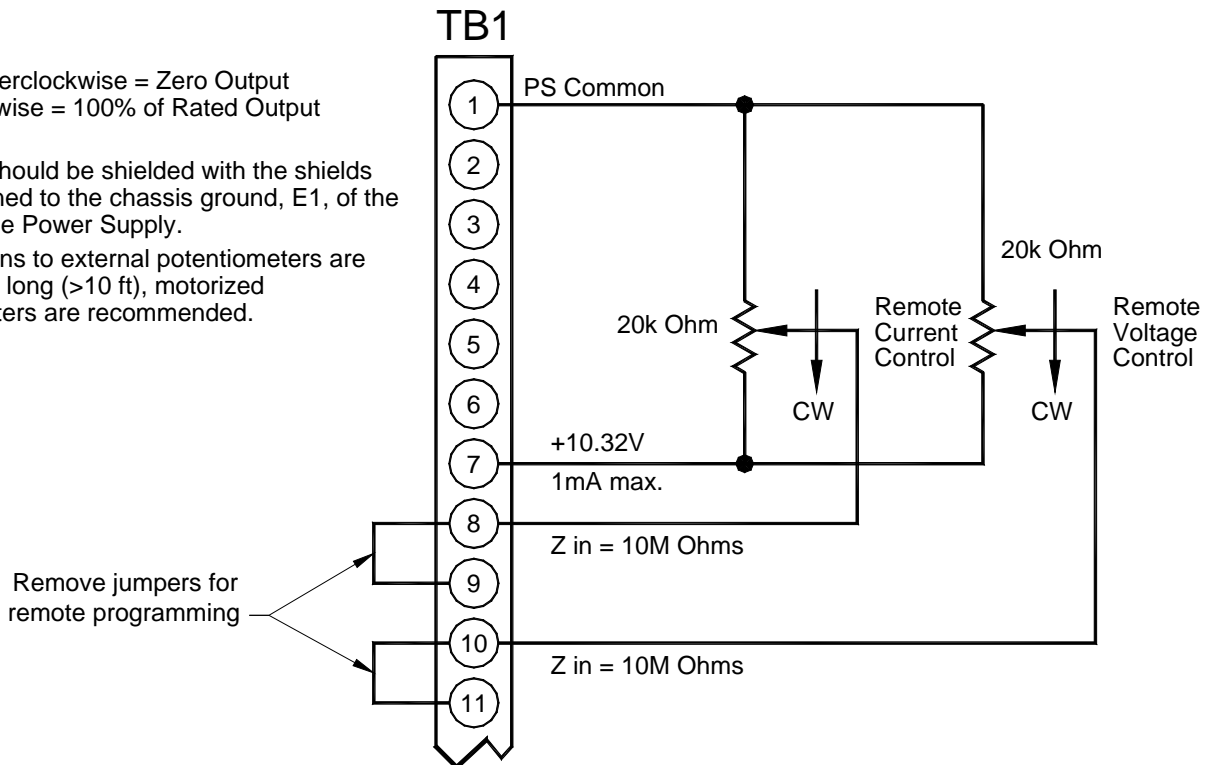

**Figure 3.2A Wiring Diagram for Remote Programming via Voltage Source**

Fully Counterclockwise = Zero Output  
Fully Clockwise = 100% of Rated Output

All cables should be shielded with the shields being returned to the chassis ground, E1, of the High Voltage Power Supply.

If connections to external potentiometers are excessively long (>10 ft), motorized potentiometers are recommended.



**Figure 3.2B Wiring Diagram for Remote Programming via External Resistance**

It is recommended that analog signals be isolated via isolation amplifiers.

All cables should be shielded with the shields being returned to the chassis ground, E1, of the High Voltage Power Supply.

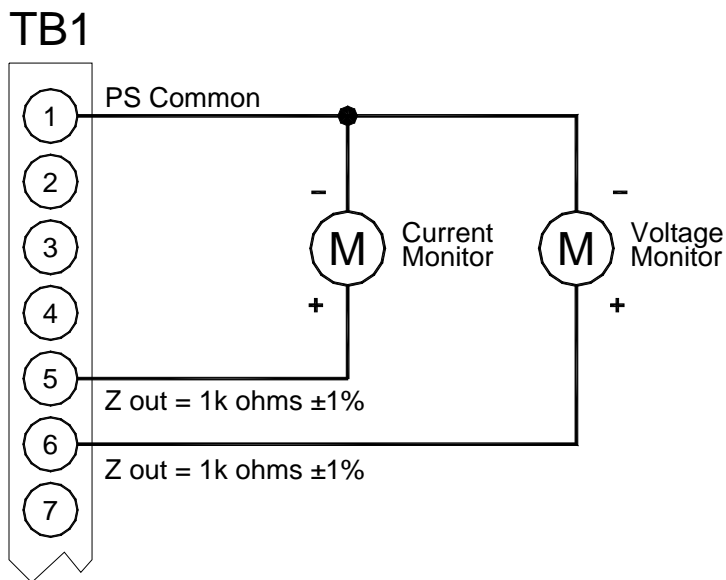
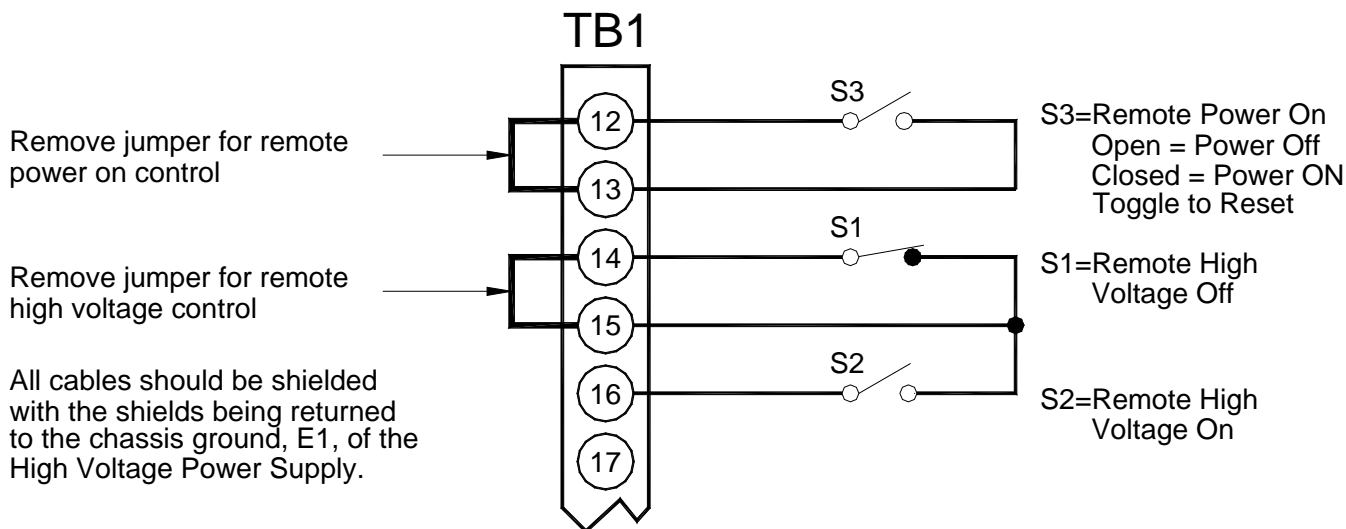

**Figure 3.3 Remote Monitor Test Point Designations**

It is recommended to use relay contacts for S1, S2 and S3. Relays should be located as close as possible to the high voltage power supply. Coils should be driven from isolated sources. Signals are at ~24V, 100mA max, and are only to be used for contact closure.

S1 must be closed to enable HIGH VOLTAGE ON. Momentary closure of S2 will enable HIGH VOLTAGE ON.

Opening S1 will disable HIGH VOLTAGE ON and switch the unit to the HIGH VOLTAGE OFF mode.



**Figure 3.4 Remote Control of Control Power ON, High Voltage ON and High Voltage OFF**

Opto-coupler should be located as close as possible to the power supply.

All cables should be shielded with the shields being returned to chassis ground, E1, of the High Voltage Power Supply.

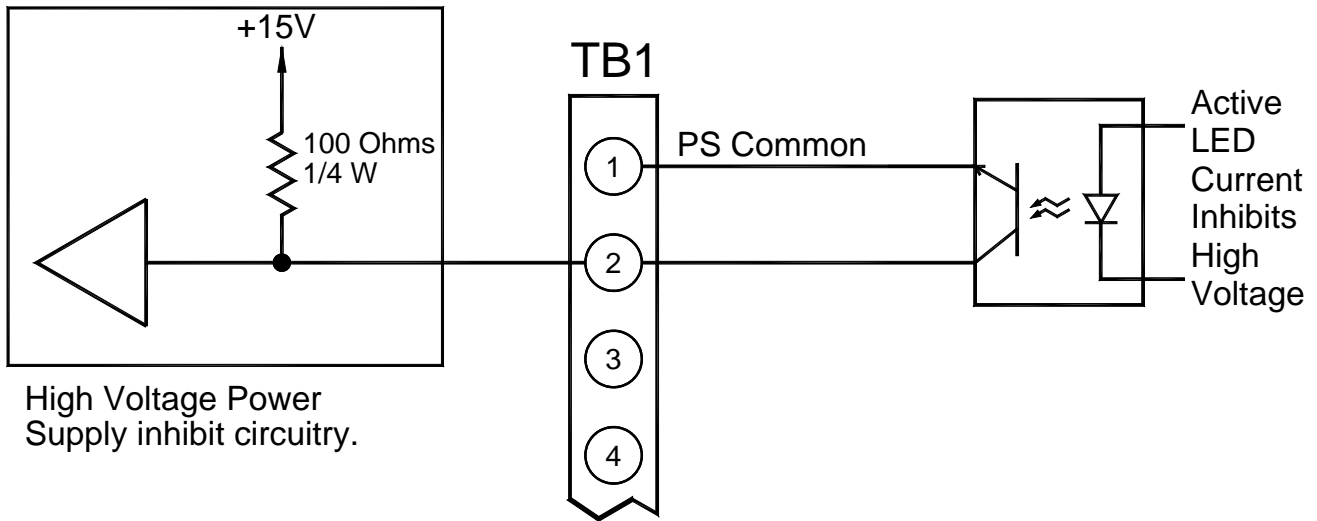

**Figure 3.5 External Inhibit Interface Circuit**

It is recommended to use relay contacts for S1. The relay should be located as close as possible to the power supply. Signals are ~24Vdc, 100mA max and are only to be used for contact closure.

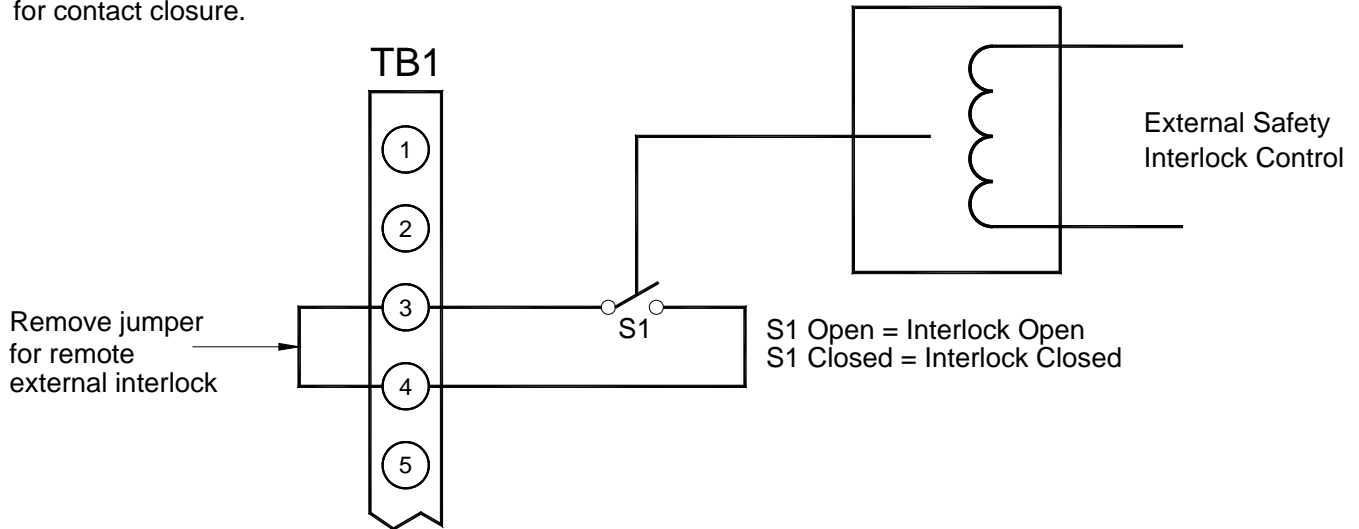

All cables should be shielded with the shields being returned to chassis ground, E1, of the High Voltage Power Supply.

**Figure 3.6 External Interlock Interface Circuit**

24Vdc lamps or relay coils may replace opto-couplers.  
 Opto-couplers, lamps or relays should be located as close  
 as possible to the high voltage power supply.  
 All cables should be shielded with the shields being returned  
 to chassis ground, E1, of the High Voltage Power Supply.

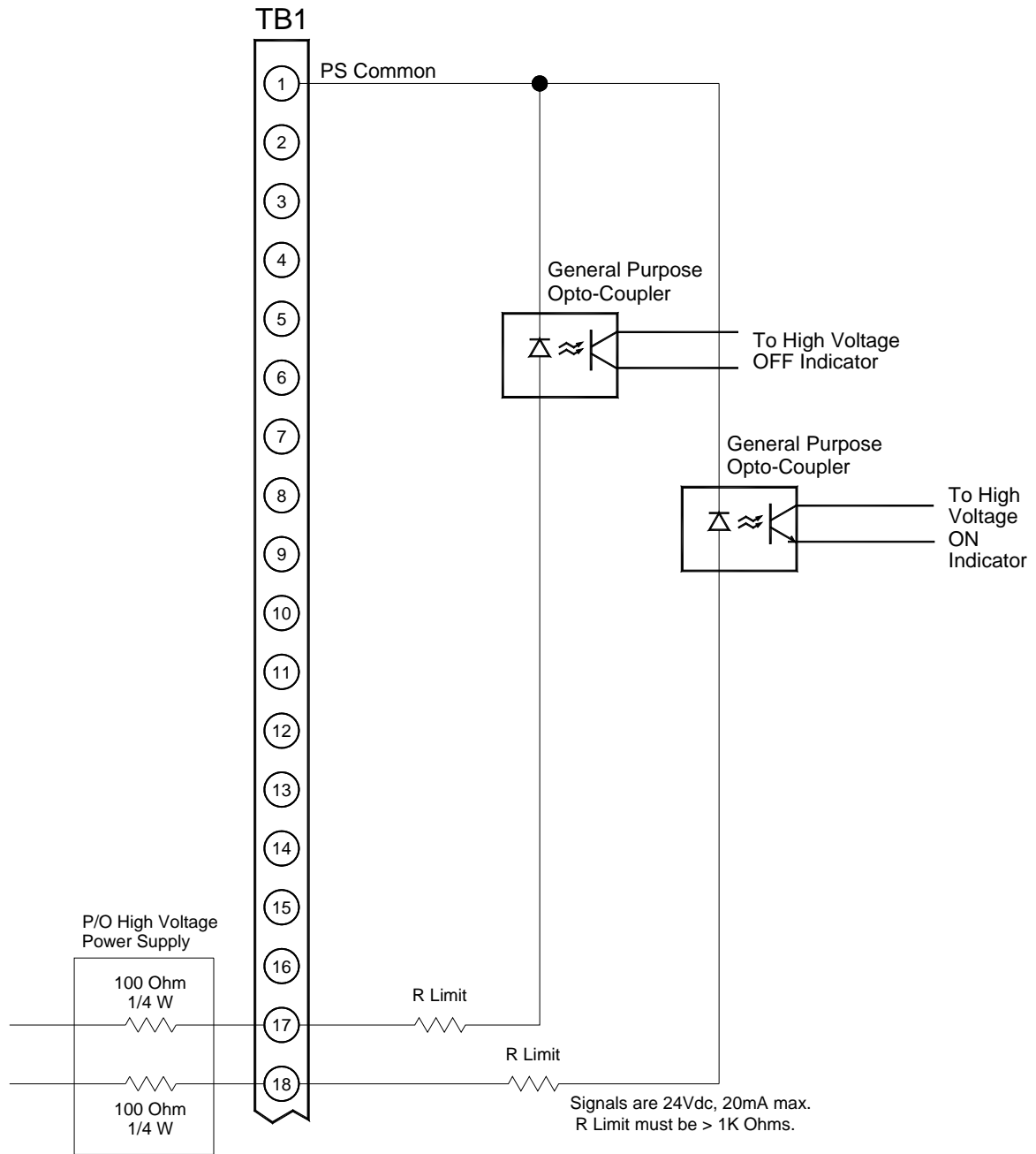

**Figure 3.7 Remote High Voltage ON and Remote High Voltage OFF Indicator**

# Chapter 4

## PRINCIPLES OF OPERATION

The SA series of high voltage power supplies utilize sophisticated power conversion technology. A variety of analog, digital and power conversion techniques are used throughout. The intention of the Principles of Operation is to introduce the basic function blocks that comprise the SA power supply. For details on a specific circuit, consult Spellman's Engineering Department.

See Table 4.1 for a list of the main assemblies found in a typical SA power supply.

\* Due to the many variations within the SA series, drawing numbers may differ from unit to unit.

The SA power supply is basically an AC to DC converter. Within the power supply, conversions of AC to DC, then high frequency AC, then to high voltage DC take place. By reviewing further the sub-assemblies, a basic understanding of the process can be gained.

### 4.1 Chassis

The SA is a compact, high efficiency, high voltage power supply. The power supply can supply up to four kilowatts of DC power. (Output power capability may be higher or lower depending upon model ordered). Output voltages of up to 70kV can be generated.

#### WARNING

**THE ENERGY LEVELS USED AND GENERATED BY THE POWER SUPPLY CAN BE LETHAL! DO NOT ATTEMPT TO OPERATE THE POWER SUPPLY UNLESS THE USER HAS A SUFFICIENT KNOWLEDGE OF THE DANGERS AND HAZARDS OF WORKING WITH HIGH VOLTAGE. DO NOT ATTEMPT TO APPROACH OR TOUCH ANY INTERNAL OR EXTERNAL CIRCUITS OR COMPONENTS THAT ARE CONNECTED OR HAVE BEEN CONNECTED TO THE POWER SUPPLY. BE CERTAIN TO DISCHARGE ANY STORED ENERGY THAT MAY BE PRESENT BEFORE AND AFTER THE POWER SUPPLY IS USED. CONSULT IEEE RECOMMENDED PRACTICES FOR SAFETY IN HIGH VOLTAGE TESTING #510-1983.**

### 4.2 Line Rectification and Filtering

Basic single phase or three phase rectification provides the DC voltage for the high frequency inverter.

The FILTER CAP ASSEMBLY and main chassis components comprise the circuits for line voltage rectification. The line input voltage can vary from 180 up

to 242 volts within the SA series. In general, the following variations can be ordered:

200Vac  $\pm 10\%$ , 50/60Hz, 400Hz, three phase or single phase.

208Vac  $\pm 10\%$ , 50/60Hz, 400Hz, three phase or single phase.

220Vac  $\pm 10\%$ , 50/60Hz, 400Hz, three phase or single phase.

Other input voltages can be accommodated. If the user is unsure which input voltage option is supplied, check the serial tag on the rear of the power supply or consult Spellman's Sales Department

Circuit protection is provided by CB1 (SYSTEM BLOCK DIAGRAM CHASSIS SA SCHEMATIC). CB1 is a fast acting magnetic trip type circuit breaker. The line input is connected directly to the line side of CB1. The load side of CB1 is connected to K1. K1 is a definite purpose contactor. K1 provides fail-safe type disconnection of the line voltage to power supply rectification circuits. K1 coil is controlled by a variety of circuit conditions, which will be described later on. The load side of CB1 is also connected to T1 via F1. F1 is a 1 amp fuse, which provides primary and secondary circuit protection for circuits supplied by T1. T1 is a step-down type line transformer. T1 provides voltage for housekeeping and control circuit power.

#### WARNING

**LINE VOLTAGE IS PRESENT WHENEVER THE POWER SUPPLY IS CONNECTED TO EXTERNAL LINE VOLTAGES. BE SURE TO DISCONNECT THE LINE CORD BEFORE OPENING THE UNIT. ALLOW 5 MINUTES FOR INTERNAL CAPACITANCE TO DISCHARGE BEFORE REMOVING ANY COVER.**

ASSEMBLY TITLE	ASSEMBLY DRAWING NO.	SCHEMATIC DRAWING NO.
SA Chassis	403790-TAB	440462-005
Filter Cap. Assembly	403735-001	440464-001
Rail Cap. Assembly	403736-001	440463-002
Inverter Assembly	403772-002	440463-002
System Control PWB	403445-001	440371-001
Inverter Drive PWB	405442-001	440870-001
High Voltage Assembly	403791-TAB	440490-TAB
Front Panel Assembly	403789-TAB	440372-001
Rear Panel Interface PWB	403782-001	440485-001

**Table 4.1 List of Main Assemblies**

When K1 is energized, voltage is applied to CR1. CR1 is an isolated diode power module. It contains the rectifier diodes used for line voltage rectification. K1 voltage also supplies power to fans used throughout the chassis for cooling purposes. The output of CR1 is connected to a capacitor filter. Capacitor C1 is initially charged through a charging resistor. This resistor is located on the AC PWR/CONTROL PWB.

Approximately 1 second after K1 contactor closure occurs, a relay is energized to short the charging resistor. This relay is K2. The DC voltage on C1 is approximately 1.4 times the input voltage. This DC voltage is supplied to the high frequency inverter through L1, and L2, on the filter cap assembly. These inductors provide isolation for the high frequency inverter if a cross conduction or “shoot thru” occurs. Hence, L1 and L2 are termed shoot thru chokes.

The AC PWR/CONTROL PWB provides a variety of control and diagnostic functions. R1 and R2 are the charging resistors previously described. These resistors limit the initial charging current for the capacitors used for line rectification. U1 and its associated circuitry monitor the voltage across the charging resistor. If any abnormal conditions appear, circuitry will shutdown the power supply. Typically a SYSTEM FAULT indication will appear on the front panel if an error in the charging circuits has occurred. DS4 (AC FAULT), located on the SYSTEM CONTROL PWB, will also indicate a fault condition. U2 and its associated circuitry monitor the rectified DC voltage. If an abnormal condition is present, the same fault indication will be generated. R5 is a bleeder resistor, which is used to discharge the filter capacitor. DS1 provides visual indication when DC voltage is present. This indicator should not be relied on for confirming the presence or absence of the DC voltage.

Resistors R3 and R4, along with diodes CR1 and CR2, provide clamping for the shoot thru inductors described above. Integrated circuits provide logic for AC fault conditions, contactor control and relay control.

The shoot thru inductors are connected to the RAIL CAPACITOR ASSEMBLY. These capacitors are high frequency, low loss type. Capacitors C1 through C4 provide the energy storage for the high frequency inverter. The DC voltage is applied to the high frequency inverter, (INVERTER ASSEMBLY SA).

### 4.3 Inverter

The inverter is a series resonant, series loaded topology. A proprietary control scheme is used for regulating the power generated from the inverter. L1, L2, L3 and L4 are the resonating inductors. The RESONANT CAP. ASSEMBLY, A1, comprise the resonating capacitors. Q1 and Q2 are high speed IGBT's. These devices provide high frequency switching to control the resonant current flow. The typical resonant operating period is approximately 20uSeconds. The gate control for the switching devices is provided by the INVERTER DRIVE PWB. VC01 and VC02 signals are generated by the SYSTEM CONTROL PWB.

The INVERTER DRIVE PWB provides the required gate pulse width and phase control. The INVERTER DRIVE PWB also provides circuitry for sensing shoot thru conditions. U7-U10 and its associated circuitry provide pulse by pulse current limiting to a defective switching device and provides the high current pulse requirements for the switching device gates. T1 provides line voltage isolation.

## 4.4 High Voltage Transformer

The output of the High Frequency Resonant Inverter is connected to the primary of the High Voltage Transformer. The High Voltage Transformer is a step-up type. Typically secondary voltages are in the range of 1kV to 4.5kV depending upon output voltage ratings.

## 4.5 High Voltage Assembly

The High Voltage Assembly will vary depending upon the model ordered. The circuitry typically consists of a full wave, full bridge, or full wave doubler for voltage outputs in the range of 1kV to 6kV. The higher voltage ranges utilize various parallel, series arrangements of a full wave voltage doubler. For example, the 8kV output is obtained by connecting a number of full wave voltage doublers in parallel. The 60kV output is obtained by connecting a number of full wave voltage doublers in series.

Output filtering is typically provided by an L-C type filter. Voltage feedback for regulation and monitoring is provided by a high bandwidth resistive/capacitive divider. Current feedback for regulation and monitoring is provided by a sense resistor connected at the low voltage end of the High Voltage Rectifier.

## 4.6 System Control PWB

The majority of control circuits for power supply controls are located on the SYSTEM CONTROL PWB. For trouble shooting and testing purposes, this board can be easily accessed by removing the four #10 screws on the sides near the front panel. The front panel will hinge down allowing for easy access to the SYSTEM CONTROL PWB.

+24VDC, -24VDC, +15VDC, -15VDC, and +10VDC are generated on the SYSTEM CONTROL PWB. High Voltage On/Off control is accomplished by K2, and its associated circuitry. Interlock control is provided by K3. System shutdown is accomplished by a logic low at U5 Pin 3. K1 provides control power On/Off switching.

Voltage feedback from the high voltage divider is sent to U6. Gain adjust is provided by R22 (KVDC CAL).

Bandwidth adjustment is provided by R18 (KV AC CAL). The KV feedback signal is sent to the front panel DVM and to the REAR PANEL INTERFACE PWB for remote monitoring. K4 provides switching between feedback and program signal for the front panel DVM's. This allows the user to preset the desired output before energizing high voltage.

Program voltages are typically ramped up to set level by the slow start circuits of U11.

Arc sense circuits T1, Q7, U5 and U9 provide sensing, quench and indication of arc conditions. Consult operation manual for a detailed description of the arc sense control.

Current feedback from the high voltage rectifier is sent to sense resistors R227 thru R232. U12 provides gain adjustment (mA CAL).

An overvoltage protection divider located in the HIGH VOLTAGE ASSEMBLY provides protection in the unlikely event of a main control loop failure. U15 provides gain adjustments for the overvoltage protection (OVP) control.

U17, U18 and U19 circuits provide signals to indicate which of the control modes is in operation. These signals are sent to the FRONT PANEL ASSEMBLY for front panel status indication.

The series resonant control circuitry consists of a voltage to frequency and a voltage to phase converter. U23 generates all frequency and phase control signals. U24, U26 and U22 provide specific phase control functions for the VCO1 and VCO2 signals.

Power supply inhibit circuits are provided by U16 and U28. Signals from the AC PWR/CONTROL PWB, the INVERTER DRIVE PWB, and the REAR PANEL INTERFACE PWB are used for inhibit control of the power supply.

System Fault Control and Indication is provided by U21, U29, U30, U31 thru U36 and associated circuitry. Diagnostic signals are latched and sent to the FRONT PANEL ASSEMBLY for status indication

## **4.7 Front Panel Assembly**

Front Panel controls, meters, and status indications are connected to the FRONT PANEL PWB. The FRONT PANEL PWB interfaces directly to the SYSTEM CONTROL PWB.

## **4.8 Rear Panel Interface PWB**

Signals going to and from the remote interface are sent through the REAR PANEL INTERFACE PWB. The

REAR PANEL INTERFACE PWB connects directly to the SYSTEM CONTROL PWB.

## **4.9 Options**

Due to the many variations of models and options provided in the SA series, details of actual circuits used may differ slightly from above descriptions. Consult Spellman's Engineering Department for questions regarding the principles of operations for the SA series.

# Chapter 5

## OPTIONS

The options available for this power supply are described in this section. Interface diagrams are shown where required. Options are specified by including the option code in the model number as described in Section 1.5.

### 5.1 Adjustable Overload Trip

**AOL**

The overload trip protection feature rapidly shuts down the high voltage output when the load current exceeds the limit set by the current control dial on the front panel. A fast acting circuit inhibits the generation of high voltage and reverts the unit to POWER DOWN mode, illuminating the OVER CURRENT indicator. When adjustable overload trip is provided, it replaces the standard current regulation feature.

### 5.2 220V AC Single Phase Input

**220**

SA power supplies with the 220 V AC input option will operate from an input voltage of 220VAC rms  $\pm 10\%$ , 50-60Hz, single phase.

### 5.3 No Slow Start

**NSS**

The no slow start option causes the output voltage of the power supply to rise (within 50 msec) to the rated voltage upon depressing the HIGH VOLTAGE ON Switch.

### 5.4 Non-Standard Slow Start

**SS(x)**

The non-standard slow start option allows the gradual rise time of the output voltage to be different from the standard of six seconds. To order the option, place the time desired in seconds after the suffix letter; i.e. SS(10) denotes a 10 second rise time.

### 5.5 Extra Length Output Cable

**LL(ft)**

Standard output cable is 10' of shielded high voltage cable. Other lengths may be specified in multiples of 10 feet.

### 5.6 Slides

**SL**

Units can be supplied with slides that mount into a standard EIA 19" wide rack.

### 5.7 Remote Over Voltage Adjust

**ROA**

This option allows the remote adjustment of the Overvoltage Trip level. This may be accomplished with a voltage source or a resistor arrangement that is similar to the Remote Program Feature. See Figure 5.1 for recommended interface.

### 5.8 Remote Mode Indicators

**RMI**

Signals are provided for remote indication of the control mode status, voltage control, current control and power control. See Figure 5.2 for the recommended interface.

### 5.9 Floating Ground

**FG**

The floating ground option allows isolation of the power supply common from chassis ground. TB3 located on the rear panel provides connection to the power supply common circuit and to chassis ground. This signal can be used for a variety of applications. A typical application for FG is for connection of an external meter or circuit into the FG point. This circuit can monitor actual current flow at a low voltage level. See Figure 5.3 for typical connection to the floating ground terminal.

#### IMPORTANT

**THE POWER SUPPLY COMMON MUST BE CONNECTED TO CHASSIS GROUND THROUGH A LOW IMPEDANCE CIRCUIT. THE POWER SUPPLY COMMON IS CLAMPED TO THE CHASSIS GROUND USING A POWER ZENER DIODE. THIS DIODE IS NOT INTENDED TO CLAMP UNDER CONTINUOUS OPERATION. ON HIGHER CURRENT UNITS THE POWER DISSIPATION CAN BE EXCESSIVE IF ALLOWED TO CLAMP. SCHEMATIC 340212-001 PROVIDES ADDITIONAL INFORMATION ON THE FG OPTION.**

It is recommended that analog signals be isolated via isolation amplifiers. If connections to external potentiometers are excessively long (>10 ft), motorized potentiometers are recommended.

All cables should be shielded with the shields being returned to chassis ground E1 of the high voltage power supply.

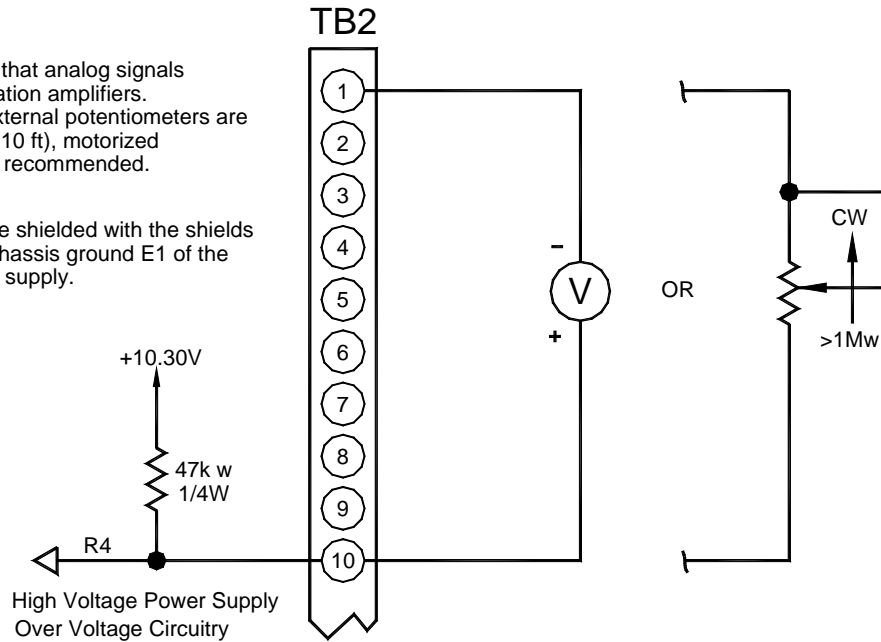

**Figure 5.1 Remote Overvoltage Adjust Interface**

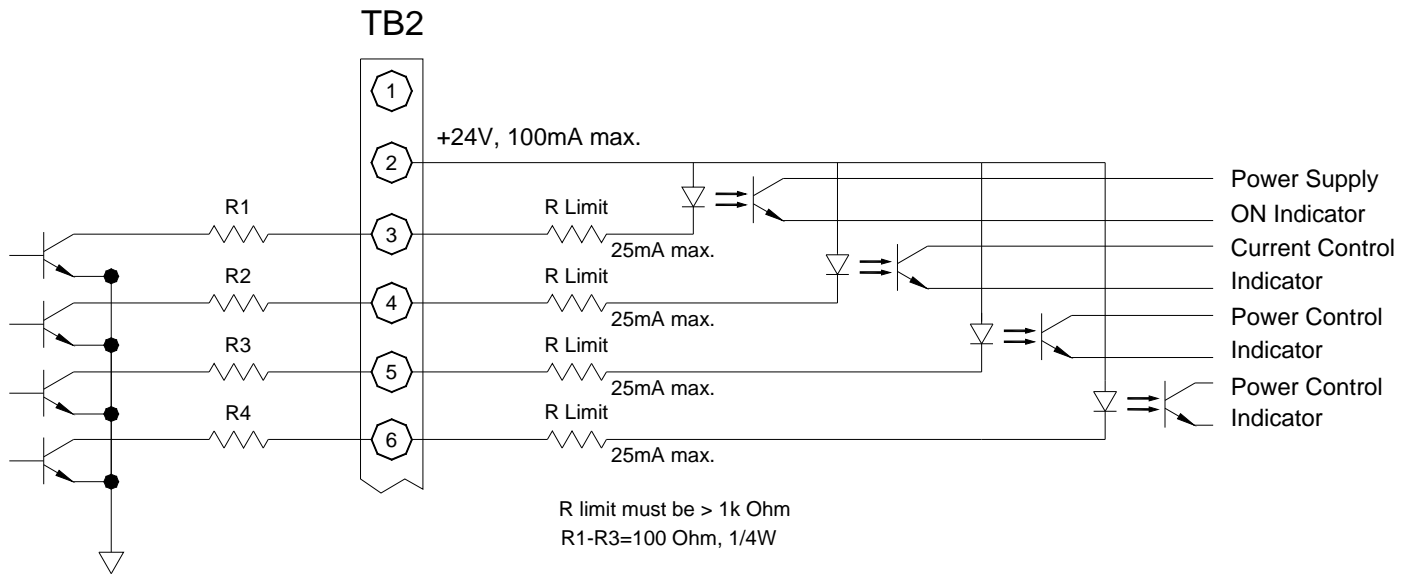

**Figure 5.2 Remote Mode Indicators Interface**

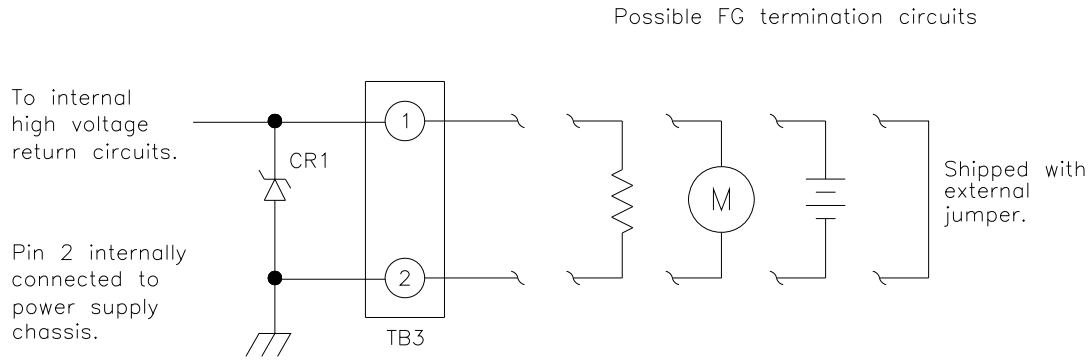

CR1— Polarity dependent on output voltage polarity. Zener voltage is 15V standard. Up to 50V is available. Consult factory.

**IMPORTANT:** Power dissipation in CR1 should not exceed 1W. This can be accomplished by keeping TB1–3 and TB3–2 voltage below Zener voltage. CR1 is for safety and transient protection only, and is not designed for continuous clamping.

**Figure 5.3 Floating Ground Interface Circuit**

## 5.10 Adjustable Power Trip/Constant Power Control

The power control option allows monitoring and control of the power supply output power. The APT option allows the user to remotely adjust the power limit for the power supply. If the power limit is exceeded, the unit will shut down with an OVERPOWER fault. The CPC option allows power regulation via a remote program source. When the unit is in power regulation, the POWER CONTROL status indicator will be illuminated. See Figure 5.4 for remote interface.

## 5.11 Custom Designed Models

**X(#)**

Units built to customer specifications are assigned an X number by the factory. If this unit is an X model, a specification control sheet is added at the end of this instructional manual.

Spellman welcomes the opportunity to tailor units to fit your requirements or to develop new products for your applications. Contact the Spellman Sales Department with your needs.

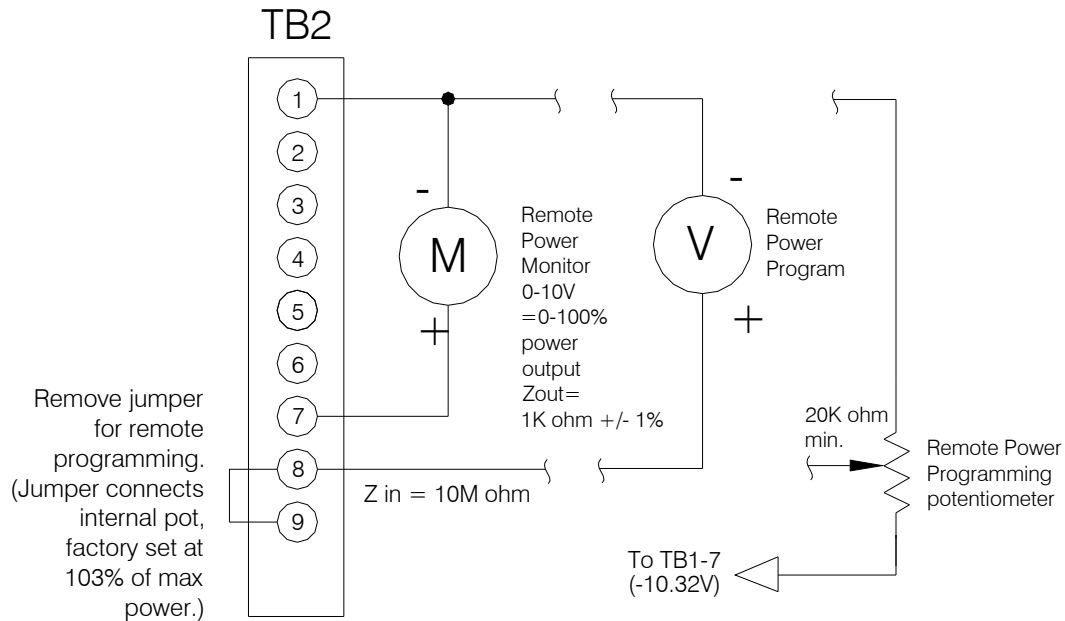

**Figure 5.4 Adjustable Power Remote Interface**

## 5.12 Parallel Option (8kW)

### PO

Parallel Option 8kW systems are comprised of two separate rack mount chassis, the Master and the Slave. The installation should be done as follows:

1. Install the racks per Figure 5.5.
2. Connect Signal Cable No. 302979-001 from Master JB5 to Slave JB5.
3. Connect Ground Cable No. 302085-009 from Master E1 to Slave E1.
4. Connect a ground cable (at least 6 AWG) to an external ground.

5. Connect H.V. Interconnect Cable from Master J1 to Slave J2.

Output Voltage	Interconnect Cable
1kV to 20kV	302039-015
30kV to 70kV	403147-103

6. Connect H.V. output cable to Slave J1.

Output Voltage	Interconnect Cable
1kV to 20kV	100161-020
30kV to 70kV	403520-001

### WARNING

**HIGH VOLTAGE POWER SUPPLIES  
MUST ALWAYS BE GROUNDED. REFER  
TO OPERATING INSTRUCTIONS IN  
CHAPTER 3.**

NOTE: Before operating this system, refer to operating instructions in Chapter 3.

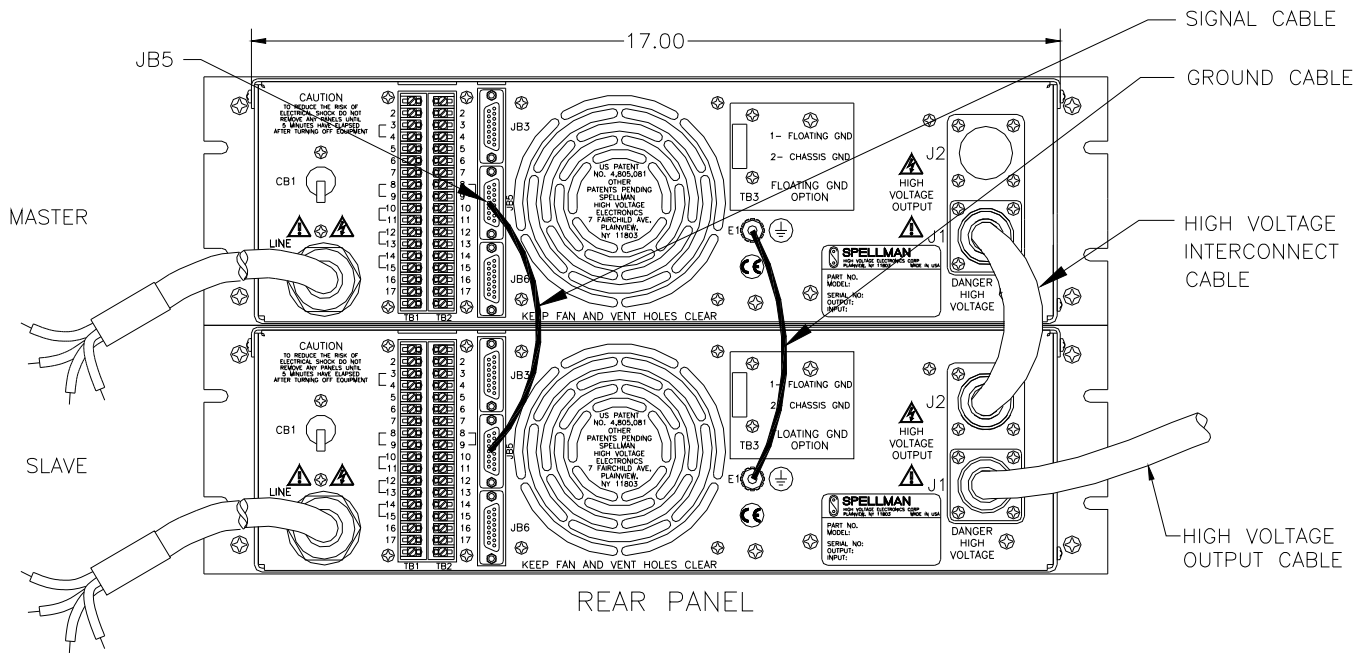

**Figure 5.5 8kW Installation Drawing**

### 5.13 Parallel Option (12kW) .....

Parallel Option 12kW systems are comprised of three separate rack mount chassis, the Master, Slave 1 and Slave 2. The installation should be done as follows:

1. Install the racks per Figure 5.6.
2. Connect Signal Cable No. 302979-001 from Master JB5 to Slave 1 JB5.
3. Connect Signal Cable No. 302979-002 from Master JB6 to Slave 2 JB5.
4. Connect Ground Cable No. 302085-009 from Master E1 to Slave E1.
5. Connect Ground Cable No. 302085-009 from Slave 1 E1 to Slave 2 E1.
6. Connect a ground cable (at least 6 AWG) to an external ground.

7. Connect H.V. Interconnect Cable from Master J1 to Slave 1 J2.
8. Connect H.V. Interconnect Cable from Slave 1 J1 to Slave 2 J2.

Output Voltage	Interconnect Cable
1kV to 20kV	302039-015
30kV to 70kV	403147-103

9. Connect H.V. output cable to Slave 2 J1.

Output Voltage	Interconnect Cable
1kV to 20kV	100161-020
30kV to 70kV	403520-001

**WARNING**

**HIGH VOLTAGE POWER SUPPLIES  
MUST ALWAYS BE GROUNDED. REFER  
TO OPERATING INSTRUCTIONS IN  
CHAPTER 3.**

NOTE: Before operating this system, refer to operating instructions in Chapter 3.

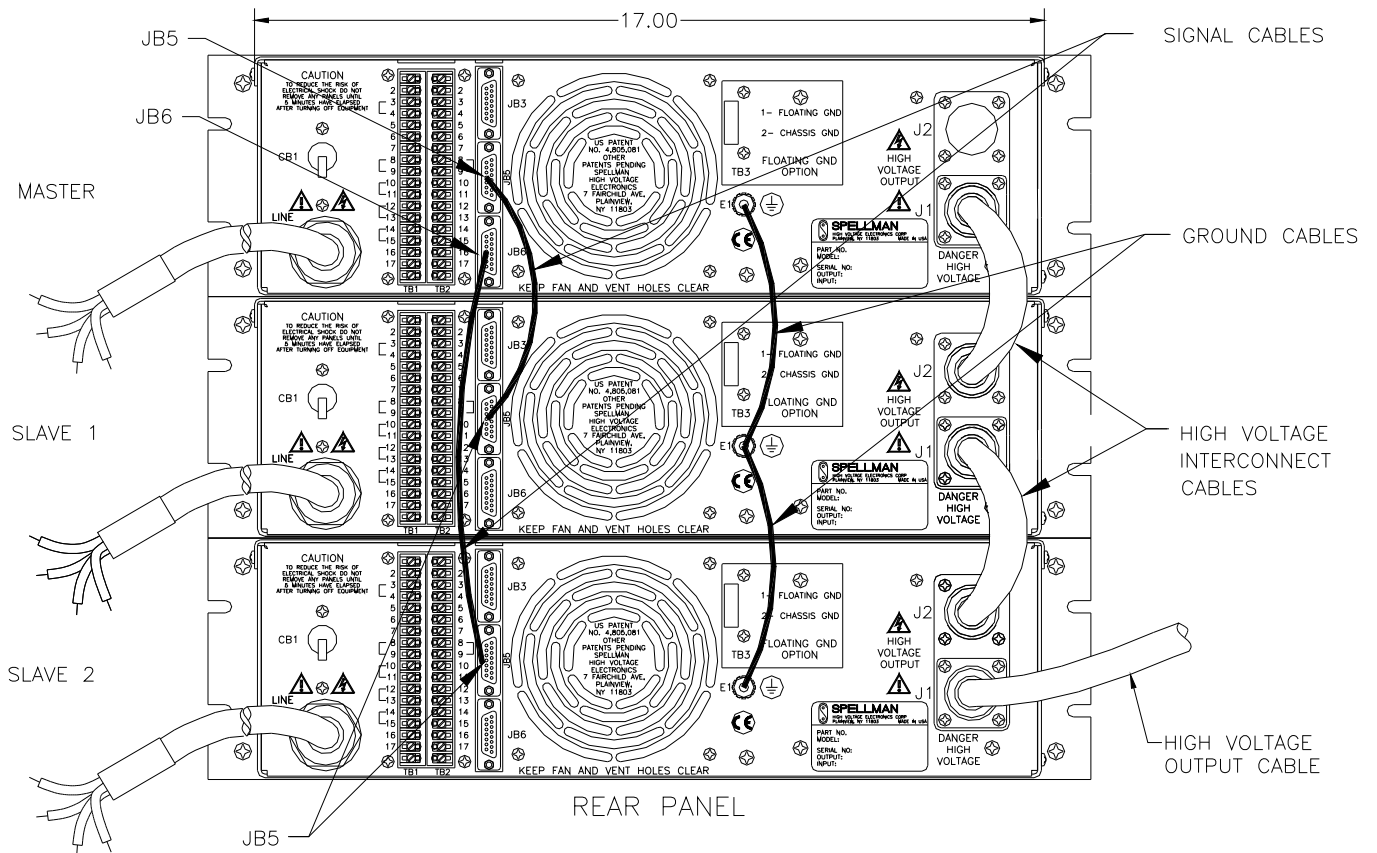

**Figure 5.6 12kW Installation Drawing**

## 5.14 REVERSIBLE POLARITY OPTION PN

Polarity reversal is accomplished on 1KV to 6KV SA models by relocating jumpers on the high voltage multiplier assembly located inside the SA chassis. 8-70KV models require the removal of the high voltage multiplier assembly and replacing it with one of the desired polarity.

The following procedure is provided for polarity reversal on these models:

### ALL MODELS:

1. De-energize the high voltage output.

### WARNING

**NEVER ATTEMPT TO CHANGE THE POWER SUPPLY POLARITY WITH THE HIGH VOLTAGE ENERGIZED. SERIOUS PERSONAL INJURY AND OR DAMAGE TO THE SUPPLY CAN OCCUR IF THE POLARITY IS SWITCHED WHILE THE HIGH VOLTAGE IS ENERGIZED.**

### WARNING

**AFTER TURNOFF, DO NOT HANDLE THE LOAD UNTIL THE CAPACITANCE HAS BEEN DISCHARGED!  
LOAD CAPACITANCE MAY BE DISCHARGED BY SHORTING TO GROUND.**

2. Disconnect the power supply from its input AC voltage source and the output load.

### WARNING

**LINE VOLTAGE IS PRESENT WHENEVER THE POWER SUPPLY IS CONNECTED TO EXTERNAL LINE VOLTAGES. BE SURE TO DISCONNECT THE LINE CORD BEFORE OPENING THE UNIT. ALLOW 5 MINUTES FOR INTERNAL CAPACITANCE TO DISCHARGE BEFORE REMOVING ANY COVER.**

3. Remove the screws securing the top cover to the chassis and remove cover.
4. Locate the multiplier assembly within the chassis. Refer to Figure 5.7

### 1-6KV MODELS:

Locate the red wire and the white wire that plug into A2-E1 and A3-E5 on the multiplier assembly. Unplug and reverse the two wires to change the polarity. Refer to TABLE 5.1. to select the configuration for the desired polarity.

### 8-70KV MODELS

5. Ref to Multiplier Replacement Procedure, SPELLMAN Drawing 403870-001, for complete instructions to replace the multiplier assembly.

### ALL MODELS:

6. Re-install the top cover. Close and secure the front panel assembly to the chassis (8-70kV only).
7. Re-connect the power supply to the input AC voltage source and the output load.

The power supply is now ready for operation in accordance with standard operating instructions described in chapter 3.

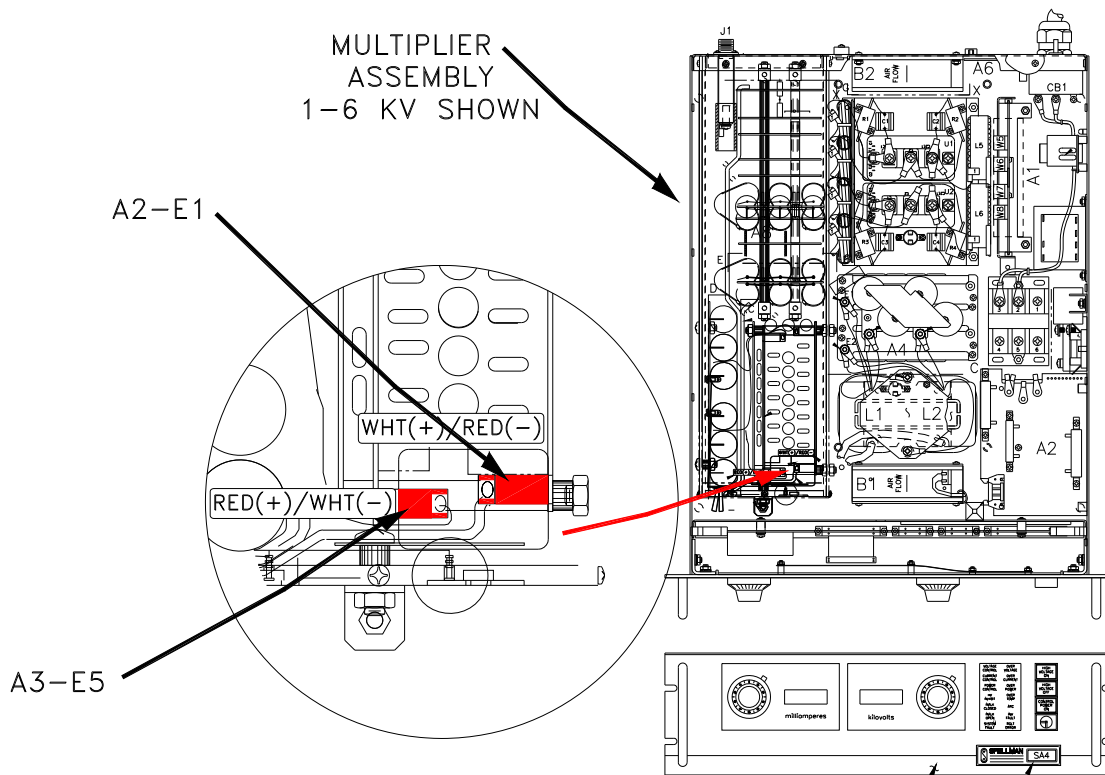

**FIGURE 5.7 POLARITY REVERSAL, 1-6 KV and MULTIPLIER LOCATION 1-70KV**

Polarity	Positive	Negative
A2-E1	White	Red
A3-E5	Red	White

**TABLE 5.1 POLARITY SELECTION TABLE 1-6KV**

# Chapter 6

## MAINTENANCE

This section describes periodic servicing and performance testing procedures.

### WARNING

**THIS POWER SUPPLY GENERATES VOLTAGES THAT ARE DANGEROUS AND MAY BE FATAL.**

**OBSERVE EXTREME CAUTION WHEN WORKING WITH HIGH VOLTAGE.**

### 6.1 Periodic Servicing

Approximately once a year (more often in high dust environments), disconnect the power to the unit and remove the top cover. Use compressed air to blow dust out of the inside of the unit. Avoid touching or handling the high voltage assembly. Be sure that the fan is not obstructed and spins freely. The fans have sealed bearings and do not need lubrication. Be sure to replace the top cover before operating for proper cooling.

### 6.2 Performance Test

#### WARNING

**HIGH VOLTAGE IS DANGEROUS.**

**ONLY QUALIFIED PERSONNEL SHOULD PERFORM THESE TESTS.**

High voltage test procedures are described in Bulletin STP-783, Standard Test Procedures for High Voltage Power Supplies. Copies can be obtained from the Spellman Customer Service Department. Test equipment, including an oscilloscope, a high impedance voltmeter, and a high voltage divider such as the Spellman HVD-100 or HVD-200, is needed for performance tests. All test components must be rated for operating voltage.

### 6.3 High Voltage Dividers

High voltage dividers for precise measurements of output voltage with an accuracy up to 0.1% are available from Spellman. The HVD-100 is used for voltages up to 100kV. The HVD-200 measures up to 200kV. The Spellman divider is designed for use with differential voltmeters or high impedance digital voltmeters. The high input impedance is ideal for measuring high voltage low current sources, which would be overloaded by traditional lower impedance dividers.

# Chapter 7

## REPLACEMENT PARTS

### 7.1 Replacement Parts

Contact the Spellman Customer Service Department for parts lists for specific models.

Spellman provides parts and subassemblies for its high voltage power supplies but recommends that only qualified personnel perform the repair. High voltage is dangerous; even minor mistakes in repairs can have serious consequences.

When requesting parts please give the model number and serial number of the power supply.

### 7.2 Correspondence And Ordering Spare Parts

Each Spellman power supply has an identification label on the rear of the chassis that bears its model and serial number.

When requesting engineering or applications information, please state the model and serial number of the power supply. If specific components or circuit sections are involved in the inquiry, it is helpful to indicate the component symbol number(s) shown on the applicable schematic diagram.

When ordering spare parts, please specify the Spellman part number, the component function and symbol from the schematic, and the model and serial number of the unit.

# Chapter 8

## FACTORY SERVICE

### 8.1 Warranty Repairs

During the Warranty period, Spellman will repair all units free of charge. The Warranty is void if the unit is worked on by other than Spellman personnel. See the Warranty in the rear of this manual for more information. Follow the return procedures described in Section 8.2. The customer shall pay for shipping to and from Spellman.

### 8.2 Factory Service Procedures

Spellman has a well-equipped factory repair department. If a unit is returned to the factory for calibration or repair, a detailed description of the specific problem should be attached.

For all units returned for repair, please obtain an authorization to ship from the Customer Service Department, either by phone or mail prior to shipping. When you call, please state the model and serial numbers, which are on the plate on the rear of the power supply, and the purchase order number for the repair. A Return Material Authorization Code Number (RMA Number) is needed for all returns. This RMA Number should be marked clearly on the outside of the shipping container. Packages received without an RMA Number will be returned to the customer. The Customer shall pay for shipping to and from Spellman.

A preliminary estimate for repairs will be given by phone by Customer Service. A purchase order for this amount is requested upon issuance of the RMA Number. A more detailed estimate will be made when the power supply is received at the Spellman Repair Center. In the event that repair work is extensive, Spellman will call to seek additional authorization from your company before completing the repairs.

### 8.3 Ordering Options And Modifications

Many of the options listed in Chapter 5 can be retrofitted into Spellman power supplies by our factory. For prices and arrangements, contact our Sales Department.

### 8.4 Shipping Instructions

All power supplies returned to Spellman must be sent shipping prepaid. Pack the units carefully and securely in a suitable container, preferably in the original container, if available. The power supply should be surrounded by at least four inches of shock absorbing material. Please return all associated materials, i.e. high voltage output cables, interconnection cables, etc., so that we can examine and test the entire system.

All correspondence and phone calls should be directed to:

**Spellman High Voltage Electronics Corp.**  
475 Wireless Boulevard  
Hauppauge, New York 11788  
TEL: (631) 630-3000 FAX: (631) 435-1620  
E-Mail: [sales@Spellmanhv.com](mailto:sales@Spellmanhv.com)  
<http://www.spellmanhv.com>

# **SPELLMAN HIGH VOLTAGE ELECTRONICS**

## **WARRANTY**

**Spellman** High Voltage Electronics ("**Spellman**") warrants that all power supplies it manufactures will be free from defects in materials and factory workmanship, and agrees to repair or replace, without charge, any power supply that under normal use, operating conditions and maintenance reveals during the warranty period a defect in materials or factory workmanship. The warranty period is twelve (12) months from the date of shipment of the power supply. With respect to standard SL power supplies (not customized) the warranty period is thirty-six (36) months from the date of shipment of the power supply.

This warranty does not apply to any power supply that has been:

- Disassembled, altered, tampered, repaired or worked on by persons unauthorized by **Spellman**;
- subjected to misuse, negligent handling, or accident not caused by the power supply;
- installed, connected, adjusted, or used other than in accordance with the original intended application and/or instructions furnished by **Spellman**.

THE FOREGOING WARRANTY IS IN LIEU OF ALL OTHER WARRANTIES, EXPRESS OR IMPLIED, INCLUDING THOSE OF MERCHANTABILITY OR FITNESS FOR A PARTICULAR PURPOSE.

The buyer's sole remedy for a claimed breach of this warranty, and **Spellman's** sole liability is limited, at **Spellman's** discretion, to a refund of the purchase price or the repair or replacement of the power supply at **Spellman's** cost. The buyer will be responsible for shipping charges to and from **Spellman's** plant. The buyer will not be entitled to make claim for, or recover, any anticipatory profits, or incidental, special or consequential damages resulting from, or in any way relating to, an alleged breach of this warranty.

No modification, amendment, supplement, addition, or other variation of this warranty will be binding unless it is set forth in a written instrument signed by an authorized officer of **Spellman**.

### **Factory Service Procedures**

For an authorization to ship contact **Spellman's** Customer Service Department. Please state the model and serial numbers, which are on the plate on the rear panel of the power supply and the reason for return. A Return Material Authorization Code Number (RMA number) is needed from **Spellman** for all returns. The RMA number should be marked clearly on the outside of the shipping container. Packages received without an RMA Number may delay return of the product. The buyer shall pay shipping costs to and from **Spellman**. Customer Service will provide the Standard Cost for out-of-warranty repairs. A purchase order for this amount is requested upon issuance of the RMA Number (in-warranty returns must also be accompanied by a "zero-value" purchase order). A more detailed estimate may be made when the power supply is received at **Spellman**. In the event that the cost of the actual repair exceeds the estimate, **Spellman** will contact the customer to authorize the repair.

### **Factory Service Warranty**

**Spellman** will warrant for three (3) months or balance of product warranty, whichever is longer, the repaired assembly/part/unit. If the same problem shall occur within this warranty period **Spellman** shall undertake all the work to rectify the problem with no charge and/or cost to the buyer. Should the cause of the problem be proven to have a source different from the one that has caused the previous problem and/or negligence of the buyer, **Spellman** will be entitled to be paid for the repair.

### **Spellman Worldwide Service Centers**

For a complete listing of **Spellman's** Global Service facilities please go to:  
<http://www.spellmanhv.com/customerservice/service.asp>